

MAINTENANCE
AUDAX PRO
USERS

Instruction and **IE**
recommendation booklet

 **IMMERGAS**

AUDAX PRO
5 - 8 - 10

1.039359ENG



Dear Customer,

Our compliments for having chosen a top-quality Immergas product, able to assure well-being and safety for a long period of time. As an Immergas customer you can also count on a qualified after-sales service, prepared and updated to guarantee constant efficiency of your heat pump. Read the following pages carefully: you will be able to draw useful suggestions regarding the correct use of the appliance. By respecting these suggestions, you will no doubt be satisfied with your Immergas product.

For assistance and scheduled maintenance, contact Authorised Immergas After-Sales centres: they have original spare parts and are specifically trained directly by the manufacturer.

General recommendations

All Immergas products are protected with suitable transport packaging.

The material must be stored in dry environments protected from bad weather.

The instruction book is an integral and essential part of the product and must also be given to the new user in the case of transfer or succession of ownership.

It must be stored with care and consulted carefully, as all of the warnings provide important safety indications for installation, use and maintenance stages.

This instruction manual provides technical information for installing the Immergas pack. As for the other issues related to pack installation (e.g. safety in the work site, environment protection, injury prevention), it is necessary to comply with the provisions specified in the regulations in force and good practice rules.

In compliance with the legislation in force, the systems must be designed by qualified professionals, within the dimensional limits established by the Law. Installation and maintenance must be performed in compliance with the regulations in force, according to the manufacturer's instructions and by professionally qualified staff, intending staff with specific technical skills in the plant sector, as envisioned by the Law.

Improper installation or assembly of the Immergas appliance and/or components, accessories, kit and devices can cause unexpected problems for people, animals and objects. Read the instructions provided with the product carefully to ensure proper installation.

Maintenance must be carried out by skilled technical staff. The Immergas Authorised After-sales Service represents a guarantee of qualifications and professionalism.

The appliance must only be destined for the use for which it has been expressly declared. Any other use will be considered improper and therefore potentially dangerous.

If errors occur during installation, operation and maintenance, due to non-compliance with technical laws in force, standards or instructions contained in this book (or however supplied by the manufacturer), the manufacturer is excluded from any contractual and extra-contractual liability for any damages and the appliance warranty is invalidated.

For further information regarding legislative and statutory provisions relative to the installation of heat pumps, consult the Immergas site at the following address: www.immergas.com

CE DECLARATION OF CONFORMITY

For the purpose and effects of the CE 2004/108 "Electromagnetic Compatibility" and CE 2006/95 Low Voltage Directives.

The Manufacturer: Immergas S.p.A. v. Cisa Ligure n° 95 42041 Brescello (RE)

DECLARES THAT: Immergas packs model:

Audax Pro 5 - 8 - 10

complies with the same European Community Directives

Mauro Guareschi

Research & Development Director

Signature:



INDEX

1	Safety precautions.....	5	5	Installing the chiller lines.....	15	8	Pump down procedure.....	26
	1.1 Hazard.....	5	5.1	Chiller line geometric limits and installation examples.....	15	8.1	Purpose of pump down.....	26
2	Unit specifications.....	6	5.2	Pipe cutting and flaring.....	16	8.2	Precautions to take before performing pump down.....	26
	2.1 Main dimensions.....	6	5.3	Selecting chiller line insulation.....	17	8.3	Precautions to take before performing pump down.....	26
	2.2 Outdoor unit specifications.....	6	5.4	Insulating the chiller lines.....	17	8.4	Transferring the coolant into an external tank before performing pump down.....	26
3	Unit installation.....	7	5.5	Welding the pipes.....	17	8.5	Recovering large quantities of coolant.....	27
	3.1 Selecting the installation position of the outdoor unit.....	7	5.6	Using Nitrogen.....	17	9	Completing installation.....	28
	3.2 Locations where the unit cannot be installed.....	7	5.7	Pressure testing and leak check.....	18	9.1	Checks at the end of installation.....	28
	3.3 Minimum installation distances for individual units.....	8	5.8	Putting under drying vacuum.....	19	9.2	Final checks and operating test.....	28
	3.4 Minimum installation distances for more than one unit.....	8	5.9	Topping up the coolant load.....	20	10	Yearly unit check and maintenance.....	29
3.5	Installing the outdoor unit.....	9	5.10	Adding coolant.....	20	11	Troubleshooting.....	30
	3.6 Outdoor unit mount structure.....	9	5.11	Putting in the coolant.....	20	11.1	Fault codes.....	30
	3.7 Drainage.....	10	5.12	Important information on the coolant used.....	20			
	3.8 Installing the unit in harsh climates.....	11	5.13	Topping up the load.....	21			
4	Electrical connections.....	12	5.14	Service valve.....	21			
	4.1 General connection configuration.....	12	6	Checking the earthing connection.....	22			
	4.2 Power cable features.....	12	7	Micro-switch setting and key function.....	23			
	4.3 Connection features between indoor and outdoor units (commonly used).....	12	7.1	Operating Test.....	23			
	4.4 Terminal board features.....	13	7.2	Data display mode.....	24			
	4.5 Supply voltage cable connection.....	14	7.3	Micro-switch setting.....	25			

1 SAFETY PRECAUTIONS

The following listed precautions must be taken scrupulously, as they are essential in ensuring the integrity of Immergas products.



HAZARD:

- Before servicing or accessing the inner parts, the Air-Water Heat Pump supply voltage must be disconnected.
- Only qualified personnel must do the installation and operating test.
- To prevent serious damage to the system and serious accidents to users, all the precautions and suggestions in this manual must absolutely be taken.

1.1 HAZARD.

- This manual must be read carefully before installation and then kept in a safe place, where it can easily be found for future needs.
- For his/her own safety, the installer is required to carefully read all the instructions contained in this manual.
- The user installation and instructions manual must be given to the user to keep in a safe place, where it can be accessed for future needs or in the event it needs to be handed over to a new user following sale of the heat pump or of the building in which it is installed.
- This manual explains the installation methods of an Immergas Water-Air heat pump system. Using unapproved components and/or different types of control systems automatically invalidates any form of Warranty provided by the manufacturer. In fact, the manufacturer cannot be held liable for damages caused by changes or methods of use that it did not previously authorise.
- This unit is compliant with the dictates of the European Union Low Voltage Directive (2006/98/CE) and Electromagnetic Compatibility Directive (2004/108/CEE).
- The manufacturer shall not be held liable for any damage caused by changes that were not previously authorised in writing or by errors in connecting the hydraulic and/or electrical lines. Failure to follow these instructions and/or using the unit out of the limits in the "Operating Limits" table automatically invalidates any form of Warranty provided by the manufacturer.
- The warranty shall be automatically invalidated in the event even just one of these instructions was not followed and the unit was made to operate outside the Operating Field (Central heating: from -25 to 35°C/Cooling: from 10 to 45°C) shown in the Unit Specifications on page 5 of this manual.
- The unit must not be used if it is damaged or shows signs of faults; for example, excessive noise or a burning smell.
- To prevent electrical shock, fires and/or accidents, if the unit gives off smoke, the power cable overheats and/or is damaged, and/or the unit becomes very noisy, it is of fundamental importance to open the protection switch and contact the Immergas Customer Assistance.
- The unit, its electrical, hydraulic and refrigerant connections, as well as its protections must be regularly inspected. All these inspection operations must only be done by qualified personnel.
- The unit must be kept out of the reach of children, as it contains live electrical components and moving parts.
- The unit must not be repaired, moved and/or reinstalled by unauthorised personnel, as to do so may cause damage to the unit and/or cause electrical shock and/or fires.
- There must be no containers containing fluids or other objects on the unit.
- All the materials used to produce and package the air-water heat pump are recyclable.
- The packaging materials and the remote control (optional) batteries, when exhausted, must be disposed of in compliance with the local standards in force.
- At the end of its life cycle, the air-water heat pump, which is special waste and contains coolant, must be disposed of by bringing it to an authorised centre or returning it to the dealer where it was purchased.
- To prevent the risk of injury from contact with the edges of the components, work gloves must be worn when unpacking, handling, installing and servicing the unit.
- The inner components (hydraulic pipes, coolant pipes, heat exchangers, etc.) must not be touched with bare hands when the unit is operating. If they must be touched, the unit must first be switched off, waiting the amount of time necessary for it to cool down and, in any case, wearing protective gloves.
- In the event of coolant leaks, do not touch the leaking coolant to avoid serious injury.
- If the heat pump is installed in a closed room, any necessary forced ventilation devices must be provided for. They must be the proper size so that, in the event of leaks, the level of coolant in the air cannot exceed the allowed limits.
- Otherwise, the people in the room under these circumstances would be subjected to serious risks of suffocation, with even fatal effects.
- The packaging material must be disposed of safely. It may contain nails or pieces of wood that could injure people.
- Upon receiving the machine, it must be inspected for any damages during transport. Should such damages be found, it **MUST NOT BE INSTALLED** and the damages found must be immediately communicated in writing to the courier or the dealer (in the event the unit was picked up at a dealer).
- The unit must be installed respecting the spaces indicated in the Installation Manual in order to make it possible to access both sides of it and carry out maintenance operations. Should it be installed not respecting the procedures indicated in this Manual, any expenses due to the need to use ladders, scaffolding or other raised systems for any warranty operations shall NOT be considered covered by the warranty itself and, therefore, shall be entirely charged to the Customer.
- The supply voltage line must have all the features required by the standards in force regarding the installation site.
- Make sure the supply voltage mains voltage and frequency are compatible with what the unit requires and that the system has enough power available to supply the unit and all the other electrical utilities it supplies. Also make sure that all the safety switches of this system are of the proper dimension.
- Make sure that the entire electrical system (cables, conductor cross-sections, protections, etc.) are compliant with the standards in force at the installation site and with the instructions contained in the wiring diagram. All the connections must also be compliant with the dictates of the local standards regarding air-water heat pump installation. Devices that can be disconnected from the electrical mains must not be in overvoltage conditions.
- The earthing connection must not be done on water or gas pipes, lightning protection systems or telephone/intercom lines as, otherwise, there would be serious risks of electrocution and/or fires.
- Both a circuit breaker switch and a safety differential switch must be installed, both with a capacity compliant with the dictates of the pertinent local standards in force.
- Otherwise, there would be serious risks of electrocution and/or fires.
- Defrost water must be able to drain normally from the unit even when the outdoor temperature is very low. Ice plugs must not be allowed to form on this line. Otherwise, the resulting water may not be able to drain out of the unit, causing large chunks of ice to form, which could, in turn, stop the unit itself from operating.
- The power cable and the communication cable between the indoor and outdoor unit must run at least 1 m away from any electrical devices.
- The unit must be protected from rodents and other small animals. If allowed to access the unit, such animals could cause malfunctions and/or cause smoke emissions or fires. The user must also be given clear instructions to keep the entire area around the unit clean and tidy.

2 UNIT SPECIFICATIONS.

2.1 MAIN DIMENSIONS.

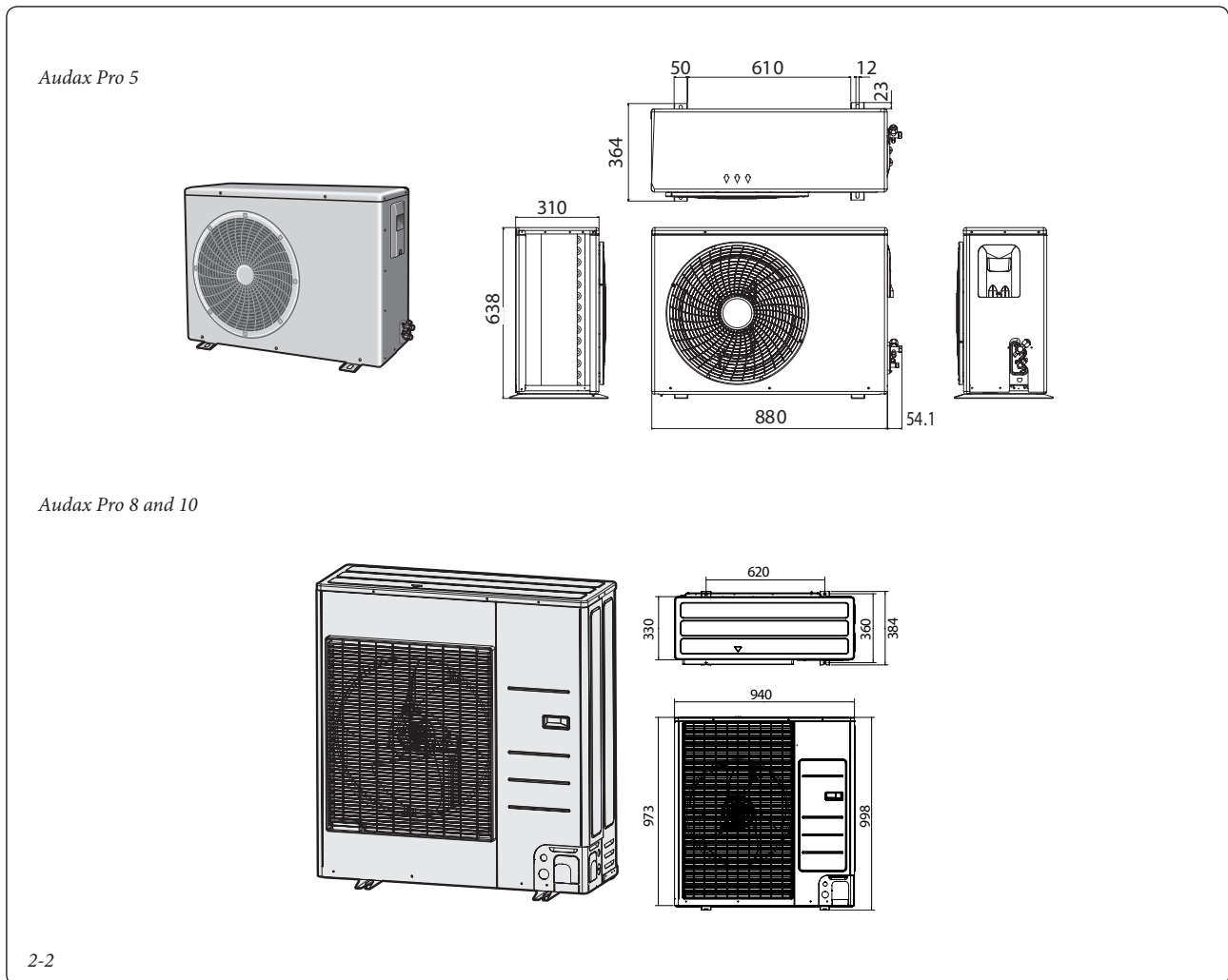

2.2 OUTDOOR UNIT SPECIFICATIONS.

Type	Unit of measurement	Audax Pro 5	Audax Pro 8	Audax Pro 10
Power Supply	-	220 ~ 240 V AC / 1 F / 50 Hz	220 ~ 240 V AC / 1 F / 50 Hz	220 ~ 240 V AC / 1 F / 50 Hz
Compressor	-	Rotary inverter	Rotary inverter	Rotary inverter
Maximum input	W	3200	4200	5100
Condenser	-	Ø 7, L 906	Ø 8, FP 1.5, L 950	Ø 8, FP 1.5, L 950
Motor fan	-	Helicoidal, Ø420.3 with 3 blades, inverter BLDC	Helicoidal, Ø420.3 with 3 blades, inverter BLDC	Helicoidal, Ø420.3 with 3 blades, inverter BLDC
Coolant load	kg	1.2	2.0	2.0
Chiller line section - liquid phase	ø	6.35	9.52	9.52
Chiller line section - gaseous phase	ø	15.88	15.88	15.88
Sound power level	dBA	62	66	66
Operating field (central heating / cooling)	°C	- 20 ~ 35 / 10 ~ 46	- 20 ~ 35 / 10 ~ 46	- 20 ~ 35 / 10 ~ 46
Water output temperature	°C	Cooling: 5 ~ 25 Central heating: 25 ~ 55	Cooling: 5 ~ 25 Central heating: 25 ~ 55	Cooling: 5 ~ 25 Central heating: 25 ~ 55
Weight (net / gross)	kg	47.5 / 52.5	74.0 / 82.0	74.0 / 82.0
Dimensions (L x H x D, overall clearance)	mm	880 x 638 x 310	940 x 998 x 330	940 x 998 x 330

3 UNIT INSTALLATION.

3.1 SELECTING THE INSTALLATION POSITION OF THE OUTDOOR UNIT.

The installation position must be identified in agreement with the user and keeping the following in mind:

- The unit must not be installed upside down or on its side, otherwise it would undergo serious damages because compressor lubrication would be jeopardised, as the oil would spill into the coolant circuit.
- The unit must be installed in a dry, ventilated position but protected from sunlight and strong winds.
- The space around the unit must be kept clean and clear of any obstacles.
- The installation position must be such that the noise from the unit and the air it discharges are not of disturbance to anyone.
- The unit must be installed in a position in which the pipes and cables can easily be connected.
- The installation position must have a stable, flat surface that can support the weight of the unit without generating and/or amplifying noises and vibrations.
- The unit must be installed in a position that allows the air to be discharged outdoors with no impediments.
- There must be no trees near the installation position and it must not be accessible to animals as, otherwise, the unit could have trouble operating.

- All around the unit, there must be the space necessary for air to circulate and there must be no stereo, radio, television, computer, etc. systems.
- If installed near the shoreline, the unit must not be directly exposed to salinity (see fig.3-1).

3.2 LOCATIONS WHERE THE UNIT CANNOT BE INSTALLED.

The unit must not be installed in sites where:

- There are mineral oils or arsenic acids. Otherwise, the parts of the unit in resin could burn, damaging it. The coolant-air exchanger could also be damaged, which would have a very negative impact on unit operation.
- There are corrosive, sulphuric or acid gases like, for example, those from chimneys or exhaust air vents. Otherwise, the unit's copper pipes could corrode, allowing the coolant to escape.
- There is the risk of flammable gas leaks or there are carbon fibres or flammable dust. Petrol and/or solvents are handled.

Attention: when the unit is installed in areas exposed to snowfall or excessively harsh temperatures (aka in areas with typically low temperatures and high humidity - that is, with temperatures below -7°C and relative humidity above 85%), ice plugs could form in the defrosting water drainage outlets.

Any build-up of ice that forms on the unit can damage it.

Attention: The unit must be installed respecting local electrical standards.

Should the weight of the unit exceed 60 kg,

wall-mounted installation is not recommendable as it is preferable to install it on the ground for safety reasons.

- If installed wall-mounted, the unit must be securely attached to the structure supporting it.
- Water or condensate produced by the unit must be able to drain out evenly and safely.
- Local regulations permitting, if it should be installed on a road, the unit must be raised at least 2 m from the pavement so as to prevent the air it discharges from disturbing passers-by (to be certain, consult the standard of town where it is installed).

In the event of installation near the shoreline, as an alternative the unit can be positioned in a place where there is an obstacle (a building, a wall, etc.) separating it from the sea breeze that could cover it in salinity.

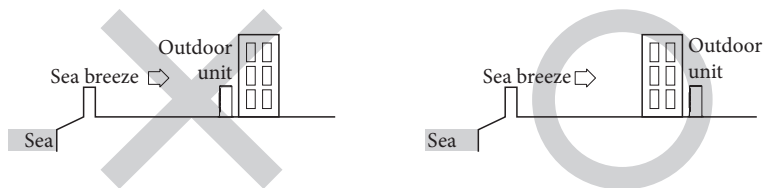

- If installed on the shoreline, the unit must always be protected by at least a wall.

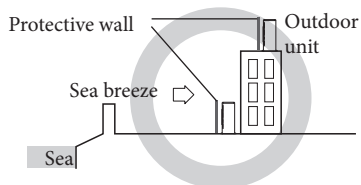

The wall must be built with heavy materials like, for example, concrete blocks and be able to stop the sea breeze. The height and width of the protective wall must be at least 1.5 times the width of the unit, which must be positioned at least 700 mm away from the wall itself so as not to impede air expulsion.

- The unit must be installed in a position in which the condensate it generates and the water resulting from defrosting can drain out normally.

Do not hesitate to contact Immergas Customer Assistance if you are unable to satisfy all the above conditions. The coolant-air exchanger must always be kept free of sand and sea water.

3.3 MINIMUM INSTALLATION DISTANCES FOR INDIVIDUAL UNITS.

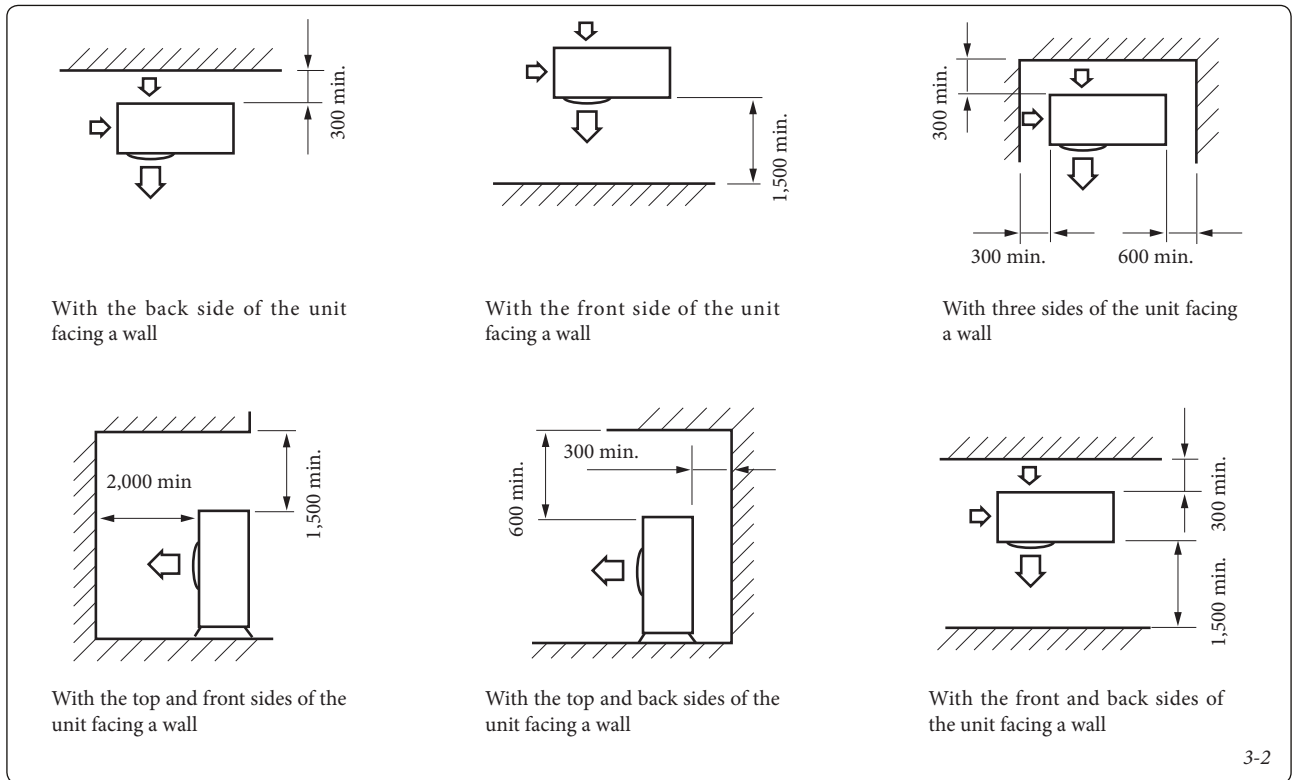

3.4 MINIMUM INSTALLATION DISTANCES FOR MORE THAN ONE UNIT.

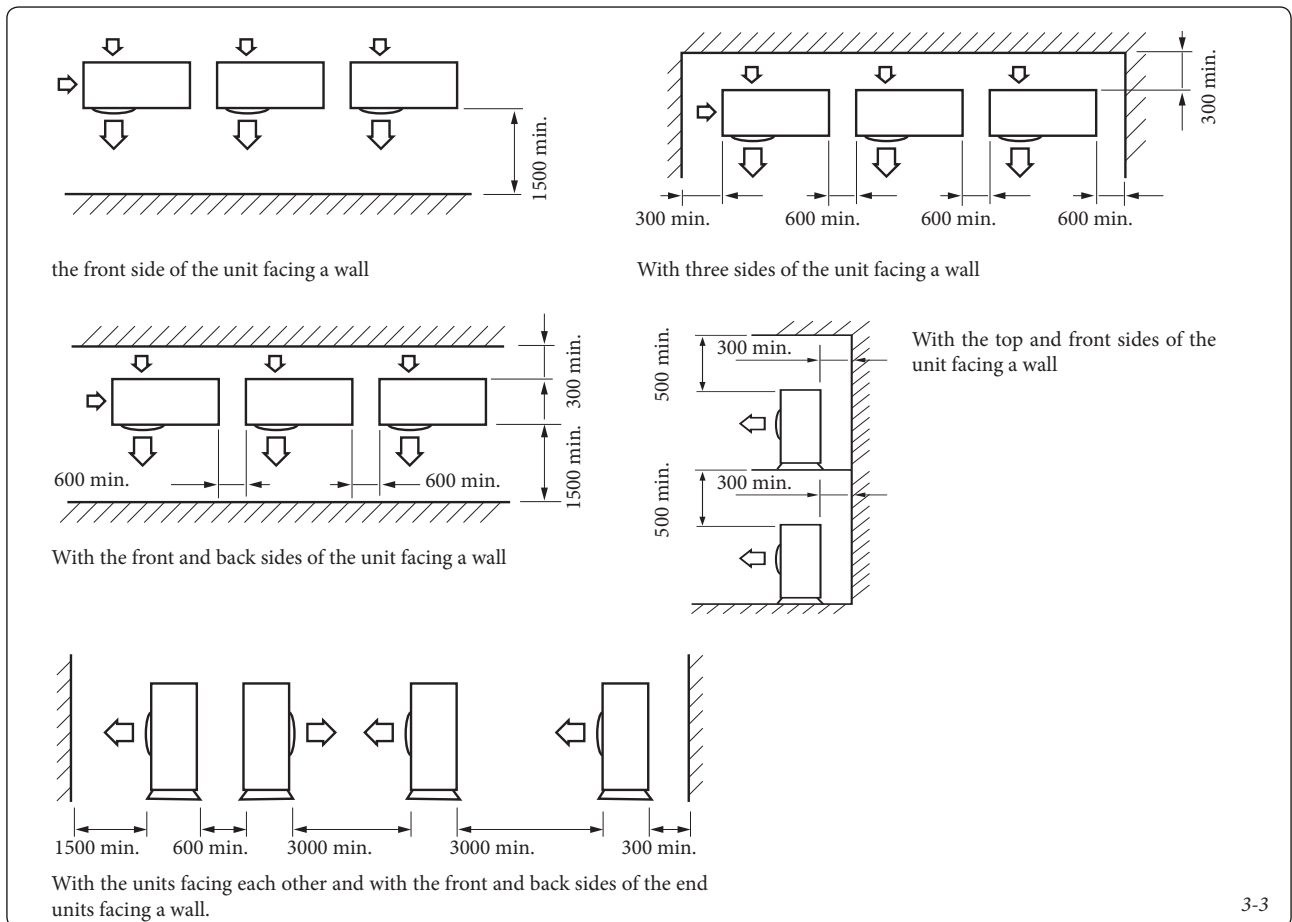

Attention: the spaces shown must be left free to allow air to circulate and to ensure accessibility for repairs or maintenance on every side of the units. In fact, it must be possible to disassemble all the unit components under the utmost safety conditions (both for objects and for people).

3.5 INSTALLING THE OUTDOOR UNIT.

To prevent the noise and vibrations it could generate from being amplified, the outdoor unit must be installed on a rigid base. Furthermore, should it be installed in a position that is exposed to strong winds or wall-mounted, it must be solidly secured to the structure supporting it (floor or wall).

The unit must be secured at the base with anchoring screws, using the anti-vibration pads provided (fig. 3-4).

N.B.: each anchoring screw must protrude by at least 20mm from the base in which it is embedded.

Attention:

- It is a good idea to insert rubber washers (not supplied) between the tightening screw nuts and the feet on the unit, as well as between the latter and the supporting base to prevent corrosion.
- A draining channel must be dug all around the base of the unit that can appropriately drain the water and condensate produced by the unit.
- When the unit must be installed on a roof, the resistance of said roof must first be checked. Install the unit without damaging the roof itself and/or its waterproofing.

3.6 OUTDOOR UNIT MOUNT STRUCTURE.

Figures 3-5 to 3-7 illustrate the instructions to install the condensing unit mount structure.

When the outdoor unit is installed on a mount structure attached to a wall, you must:

- Make sure the wall can support the weight of the support structure plus the weight of the device;
- Install the mount structure with the least amount of overhang possible;
- Insulate the structure with respect to the wall by inserting rubber dowels between them to prevent vibrations from being transmitted to the wall.
- **Attention:** the machines cannot be ducted.

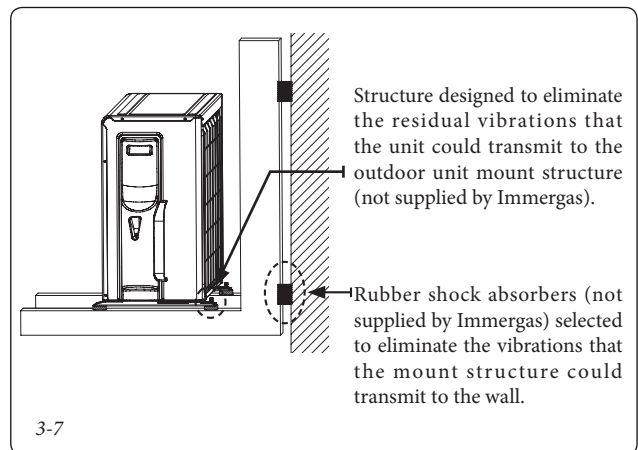
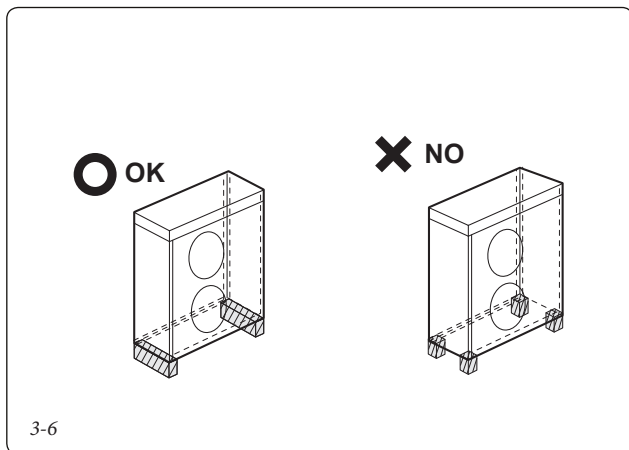
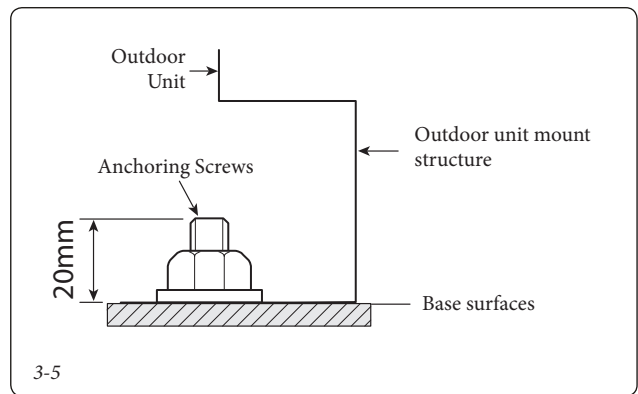
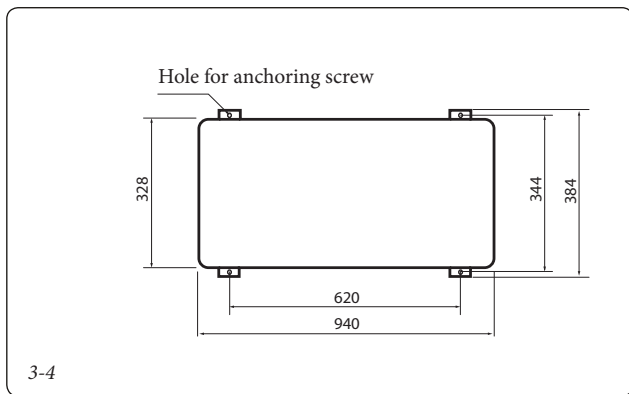

3.7 DRAINAGE.

During central heating, ice can deposit on the outer surface of the coolant-air exchanger. To prevent these deposits from becoming excessive, the unit runs defrosting cycles to melt them. The water resulting from this process is eliminated via drainage holes to prevent it from re-solidifying at the bottom of the unit when the outdoor temperature is quite low.

- If, for whatever reason, this water cannot be allowed to drain freely, you must:
 - Leave a space of at least 50 mm (5 kW version) and 100 mm (8 / 10 mm version) from the support surface (Fig. 3-8).
 - Insert the drainage fitting in one of the three drainage holes on the bottom of the unit and plug the other three with the supplied drain plugs.
 - Connect the drainage fitting to a hose that conveys the water to the desired location.
 - Prevent dust and debris from entering the drainage hose.

Attention: if the water produced by the unit is not properly drained, the performance of the entire system will suffer a negative impact and the system itself could be damaged.

Warnings.

- 1 Dig a draining channel all around the base of the unit that can appropriately drain the water and condensate produced by the unit.
- 2 To facilitate drainage, you can install the unit on a base of cement blocks so that it is at least 150 mm off the ground.
- 3 The unit must be raised at least 150 mm off the ground to prevent it from being flooded in the event of heavy rain.
- 4 If installed in a snowy area, the unit must be raised off the ground by at least the height of the heaviest foreseeable snowfall.
- 5 If wall-mounted (see figure), it is a good idea to position a container (not supplied by Immergas) about 150 mm below the bottom of the unit to collect and drain the condensate that may drip from the unit.

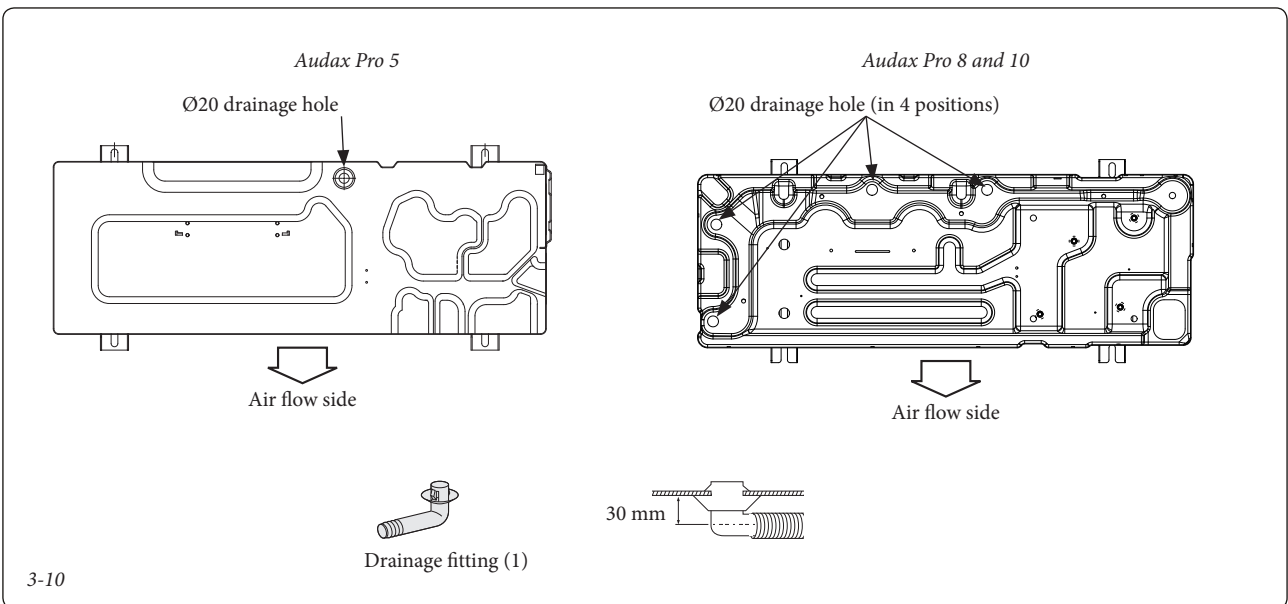
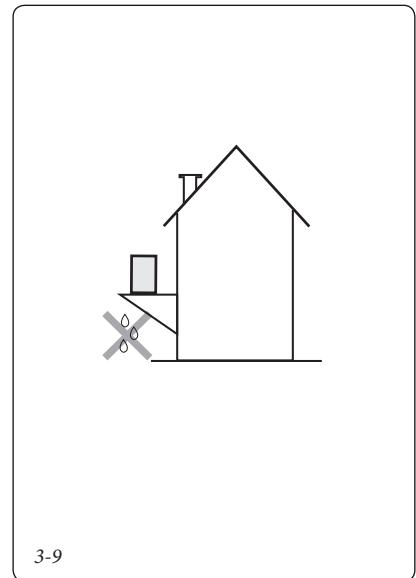
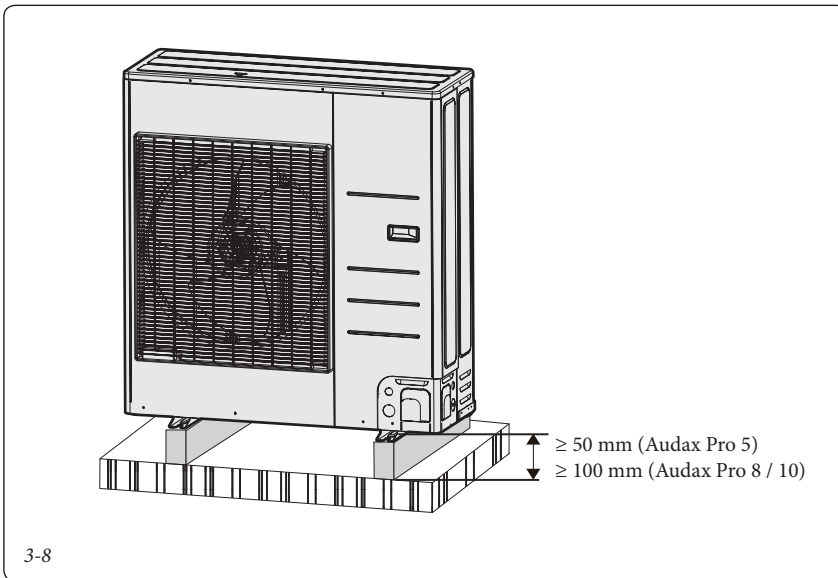

3.8 INSTALLING THE UNIT IN HARSH CLIMATES.

N.B.: if installing the unit in harsh climates, you must follow all the instructions below.

- The effects of the wind can be minimised by installing the unit with the intake side facing a wall.
- The unit must not be installed with the intake side against the wind.
- The effects of the wind can be further minimised by installed a deflector plate facing the unit air flow side.
- The unit must be installed in a position protected from snow falling from above. If this is not possible, you must at least prevent the snow from clogging the air coolant exchanger (even by constructing a small protective roof for the unit, if necessary (Fig. 3-11)).
- The fan in the outdoor unit will work normally with the K7 micro-switch on "ON" to prevent snow from accumulating in the unit. (see parag. 7.3)
- The direction the unit faces depends on the direction of the strongest winds. As it could overturn with strong winds, the unit must be oriented with one of its narrower sides against the wind.

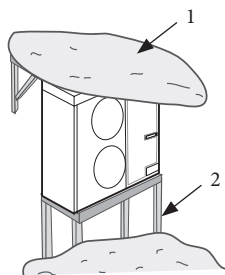

1 - Overall protective roof.

2 - Raised base.

The base must raise the unit from the ground by at least the height of the heaviest foreseeable snowfall.

3-11

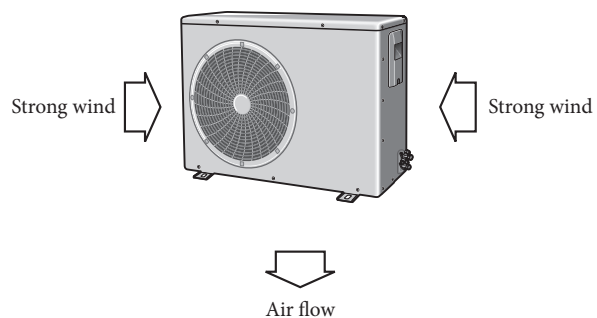

3-12

4 ELECTRICAL CONNECTIONS.

4.1 GENERAL CONNECTION CONFIGURATION.

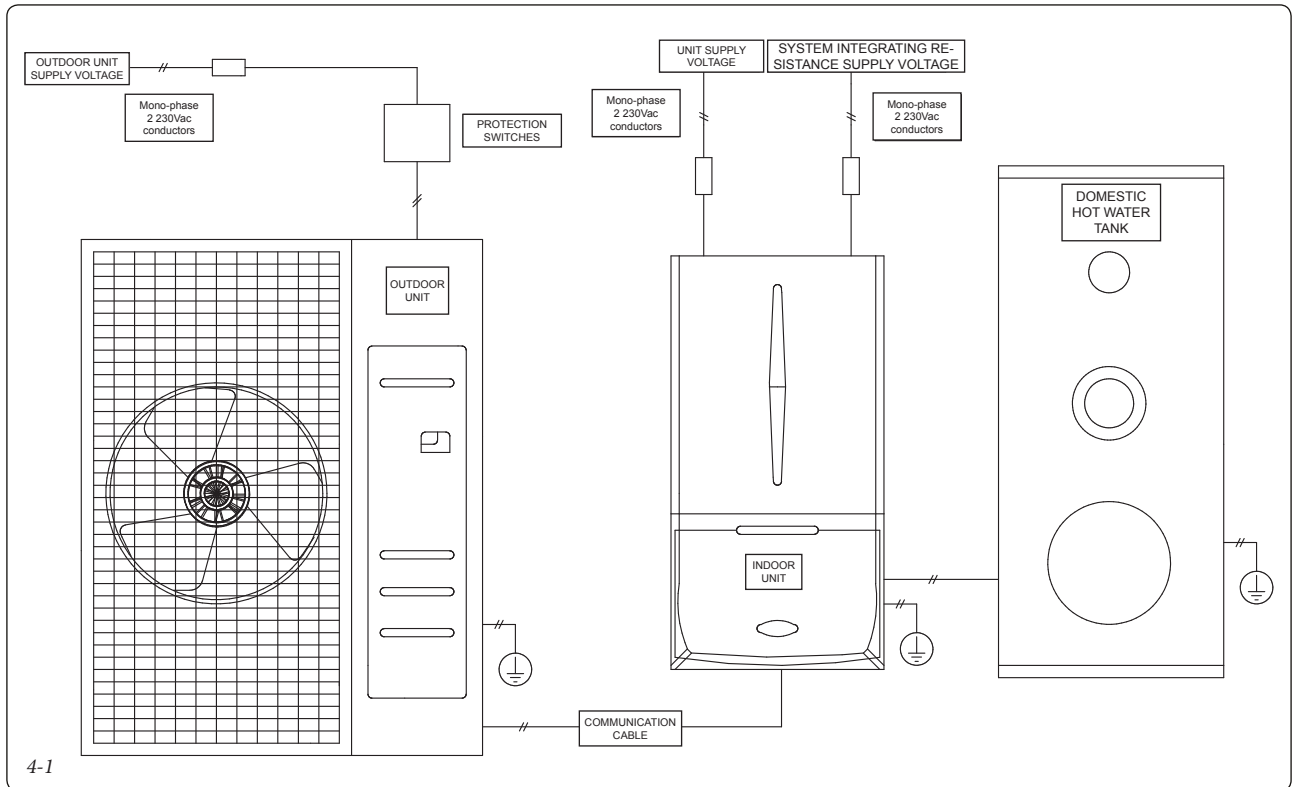

4.2 POWER CABLE FEATURES.

- The power cable is not supplied with the unit.
- The outdoor unit power cable must be suitable for outdoor installation and must have at least a flexible polychloroprene sheath (Code IEC:60245 IEC 57 / CENELEC:H05RN-F)

Attention: should the connection cable require an extension, do not use a circular pressure terminal. Connection cables with connections that are not to code can be the cause of electrical shock and fires.

Mono-phase.

Outdoor Unit	Nominal Values		Field of Tolerable Voltage		Maximum absorbed current (MAC) in normal operation	MAC*1.25 + Additional Load	Fuse capacity necessary for the unit
	Hz	V	V	V.			
5 kW	50	220 - 240	198	264	20	25.0	30
8 and 10 kW	50	220 - 240	198	264	22	27.5	40

4.3 CONNECTION FEATURES BETWEEN INDOOR AND OUTDOOR UNITS (COMMONLY USED).

Use H07RN-F or H07RN-F class cables to power the indoor unit.

When the indoor unit is installed in a room with a computer or internet server, you must use a double shielded FROHH2R class cable (Aluminum tape/Polyester + Copper braid).

Supply Voltage	Supply Voltage		Communication cable
	Max./Min.(V)	Connection cable	
Mono-phase, 220-240V, 50Hz	±10%	0.75 ~ 1.5mm ² , 3 wires	0.75 ~ 1.5mm ² , 2 wires

4.4 TERMINAL BOARD FEATURES.

Audax Pro 5 - Supply voltage in mono-phase AC.

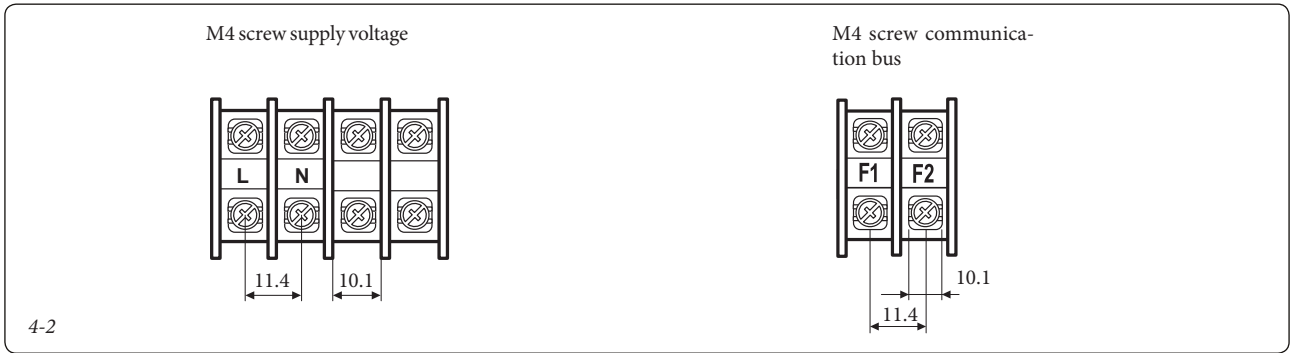

Audax Pro 8 and 10 - Supply voltage in mono-phase AC.



4.5 SUPPLY VOLTAGE CABLE CONNECTION.

Attention:

- After connecting it to the terminal board, the power cable must be secured using a cable locking terminal.
- Voltage imbalance must not exceed 2% of nominal voltage

- Otherwise, condenser duration could be jeopardised. Should imbalance exceed 4%, the indoor unit would stop and an error would be signalled
- To protect them from water and possible mechanical trauma, the power and communication cables must run through a cable duct (with an IP protection that is compliant with the specific application requirements).

- The power cable must be connected to a 230V $\pm 10\%$ / 50Hz mains, respecting L-N polarity and the earthing connection ; this network must have a multi-pole circuit breaker with class III overvoltage category.
- In the event of overvoltage, all the units connected to the supply voltage line must automatically disconnect.
- The communication cable must run at least 50 mm away from the power cable.

With use of the mono-phase safety switch (ELB).

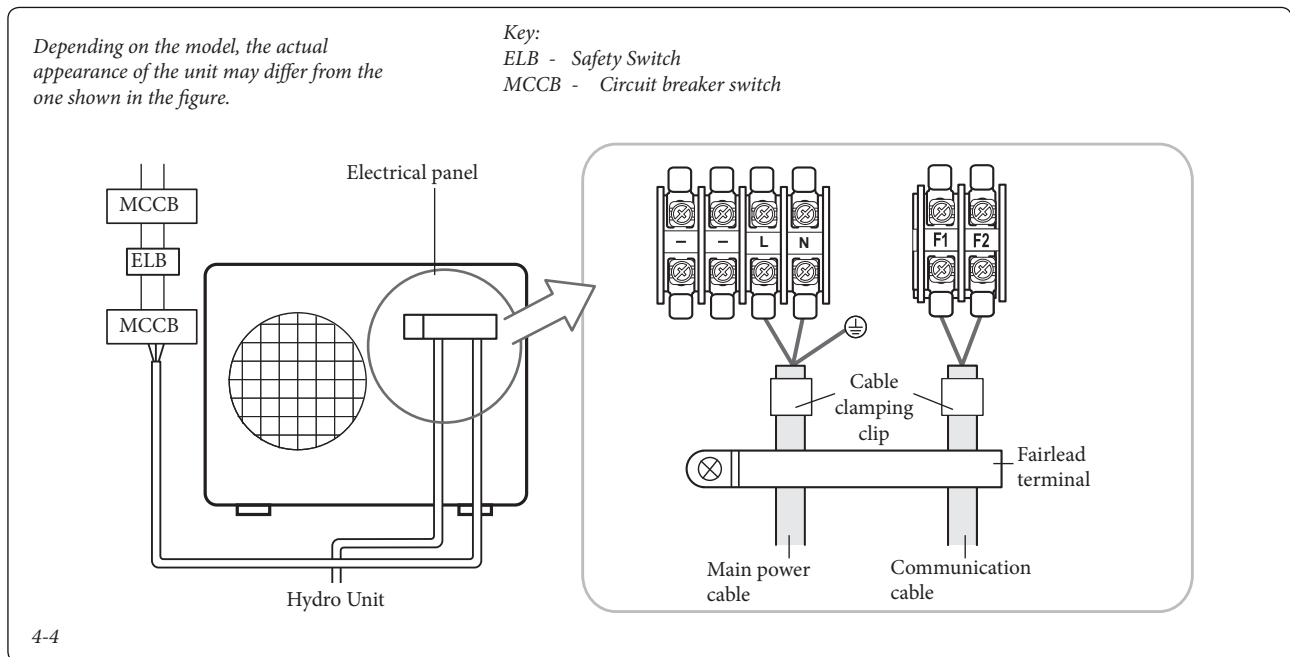

Connection to the supply voltage terminal board.

- The connection must be made after having secured the wires to ring compression terminals.
- Only use the types of cables specified.
- For the connection, you must only use screwdrivers that can give the screws the prescribed tightening torques.
- Should the connection be loose, voltaic arcs could be triggered, which could, in turn, cause fires. Instead, should the connection be excessively tightened, the terminal could be damaged.

Tightening torques (kgf·cm) for terminal board screws:

- M4 12.0 ÷ 14.7
- M5 24.4 ÷ 29.8

Connecting the earth cable.

- Only use the types of cables specified among the features of outdoor unit cables.
- For the earthing connection, use a type of cable specified for the outdoor unit.

Power cable earthing connection.

- The connection method depends on the nominal voltage and the site in which the Heat Pump is installed.
- In any case, the features of this connection must be the following:

Earthing connection.

- The earthing connection must be done by a specialised electrician.
- Make sure the resistance to earth is < 100 Ohm. If there is a circuit breaker switch to interrupt the circuit in the event of a short circuit, the resistance to earth can be 30 ÷ 500 Ohm.

5 INSTALLING THE CHILLER LINES.

- The length of the pipes between the outdoor and indoor units and the difference in the pipe lengths after the first junction and the drop must not exceed the indicated limits.
- R-410A is a high pressure coolant.
- Only use pipes that are certified for chilling and follow the installation methods below.
- Only use clean pipes with no harmful ions, oxides, dust, traces of iron or moisture.
- Only use equipment and fittings for R-410A.

Manometric unit. Use an R-410A manometric unit to keep foreign objects from getting into the chiller lines and prevent reading errors.

Vacuum pump. Only a vacuum pump with a non return valve must be used to prevent the oil inside it from getting into the chiller circuit when it stops. This pump must be able to create a vacuum of up to 500 mTorr (66 Pa).

Flare nuts. Only use the flare nuts supplied with the unit.

5.1 CHILLER LINE GEOMETRIC LIMITS AND INSTALLATION EXAMPLES.

The maximum lengths of the chiller lines are listed below, based on the condensing unit model and the type of installation (fig. 5-1).

	Audax Pro 5	Audax Pro 8 and 10
A	≤ 30 m	≤ 50 m
H1	≤ 20 m	≤ 30 m
H2	≤ 20 m	≤ 15 m

N.B.: it is recommendable to provide for a siphon in the immediate vicinity of the condensing unit.

If the length of the chiller line is greater than the one given in the machine pre-load, it is recommendable to provide for a siphon halfway.

A siphon is also recommendable in the event of installation with drops between the condensing unit and the hydronic unit.

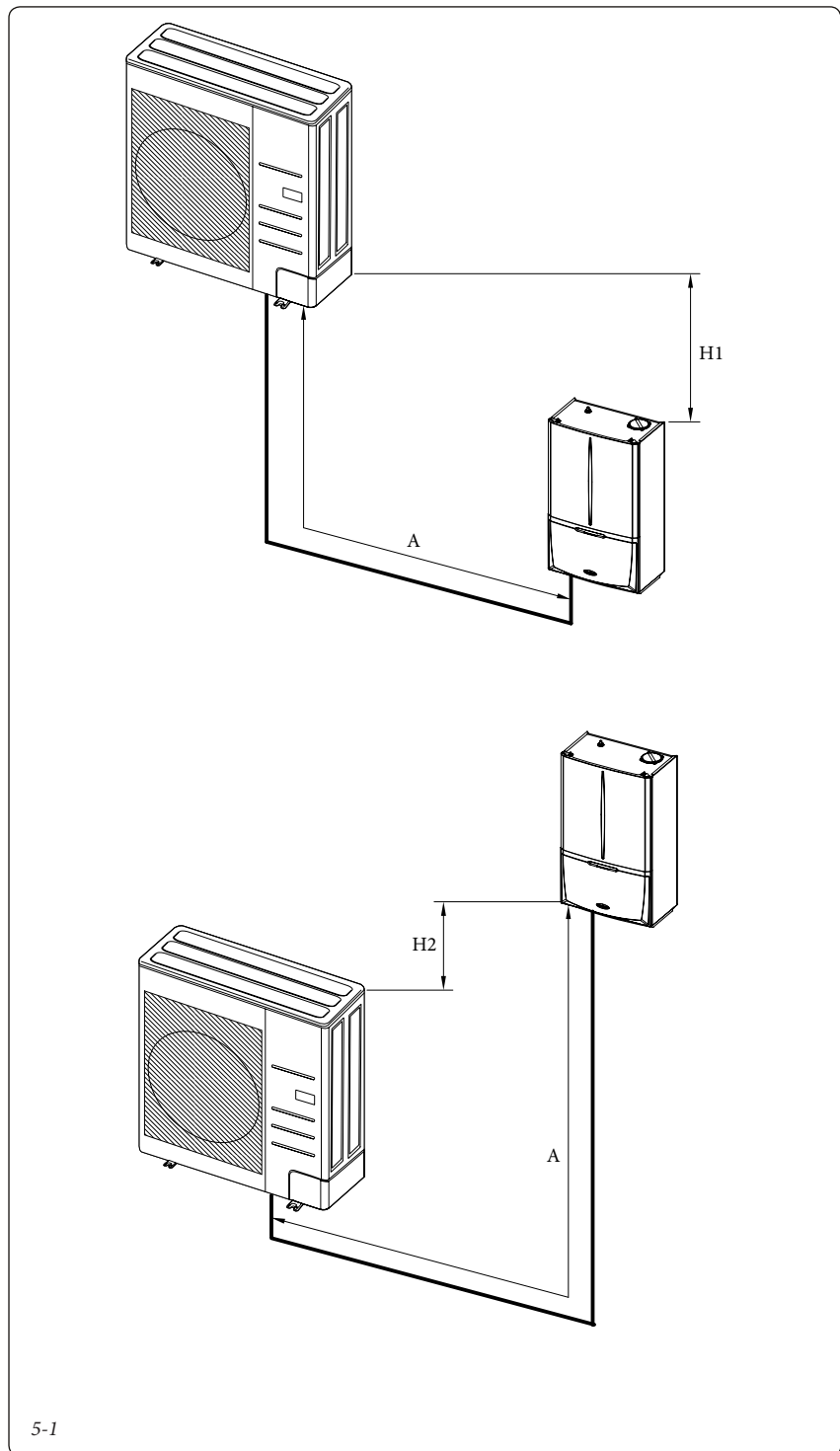

5.2 PIPE CUTTING AND FLARING

1 Make sure you have all the equipment necessary: pipe cutter, deburring tool, flaring tool, clamp, etc.

2 If the pipe needs to be shortened, it must be cut with a pipe cutter, being careful to keep the cutting angle at 90° with the pipe axis. Figure 5-2 shows some examples of correctly and incorrectly made cuts.

3 To prevent coolant leaks, cutting burrs must absolutely be eliminated using a deburring tool.

Attention: during deburring, the pipe must be facing downward to prevent shavings from getting into it (see fig. 5-3).

4 Insert the nut in the pipe, then flare it according to the features indicated in figure 5-4

5 Make sure flaring has been done properly. Figure 5-5 shows some examples of correctly and incorrectly done flaring.

6 Align the pipes to make connection easier. Tighten the flare nut by hand at first, then definitively, using a dynamometric key calibrated to the torque shown in figure 5-6.

N.B.: tightening to an excessive torque can cause coolant to leak.

Attention: any welding must be done in a Nitrogen atmosphere.

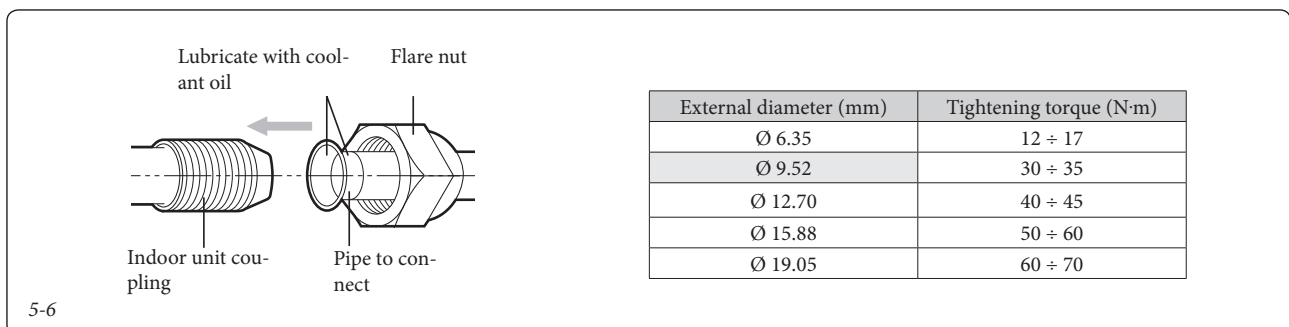
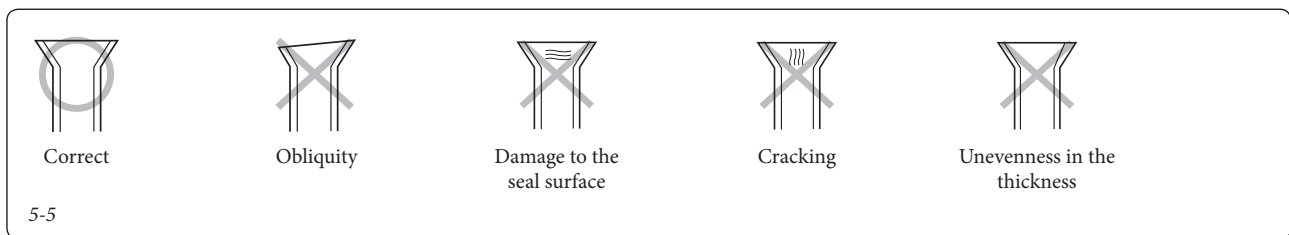
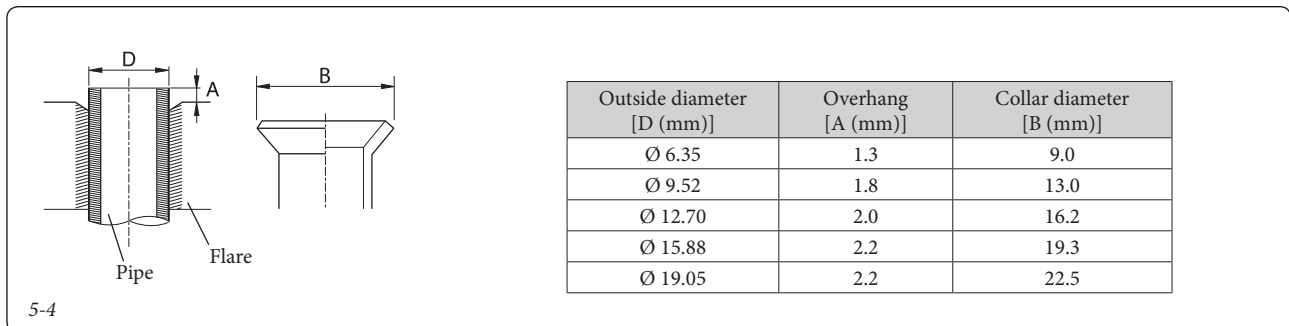
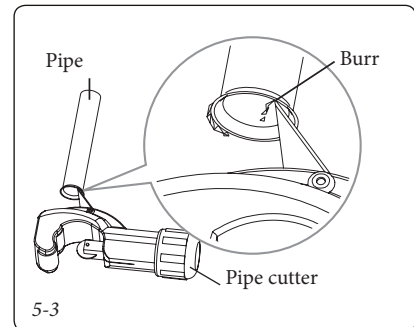
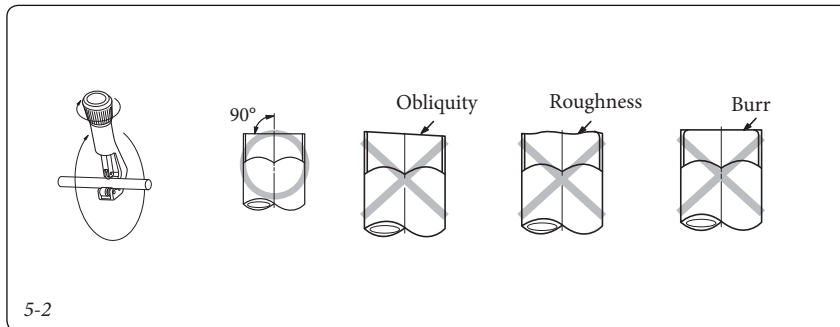

5.3 SELECTING CHILLER LINE INSULATION.

- The gas and liquid chiller lines must be insulated with materials selected based on their respective diameters.
- Standard insulation is required at a temperature of 30°C with 85% relative humidity. Should the thermohygrometric conditions of the air be harsher, you must use insulations that can be selected from the table in figure 5-7
- **Attention:**
 - The insulation cannot be interrupted and for this reason, its junctions must be sealed with adhesive to prevent moisture from getting in.
 - Should the insulation be exposed to sunlight, it must be protected by wrapping it with electrical tape or material suitable for this type of application.
 - The insulation must be laid without its thickness being reduced in the bends and supports of the pipes.

5.4 INSULATING THE CHILLER LINES.

- The insulation must only be laid after having made sure that there are no coolant leaks on the lines.
- Use EPDM insulation with the features described in the table in figure 5-8.
- The chiller lines, the junctions and the connections must be insulated with class "0" (zero) material.
- Proper insulation prevents condensate from forming on the surface of the pipes and protects heat pump performance and the level of user satisfaction.
- Make sure that the insulation is not broken and/or interrupted in the pipe bends (Fig. 5-9).

5.5 WELDING THE PIPES.

- Make sure there is no moisture inside the pipes
- Make sure there are no foreign objects inside the pipes.

5.6 USING NITROGEN.

- 1 Welding must be done in a nitrogen atmosphere, that is, insufflating the pipes with nitrogen as shown in figure 5-10.
- 2 Should welding be done without insufflating nitrogen, flakes of rust would form inside the pipes. In coming loose, these flakes could damage the compressor and the valves.
- 3 The flow of nitrogen must be controlled, calibrating the pressure regulator so as to obtain a flow of at least 0.05 m³/h.
- 4 The valves must be protected from heat while they are being welded.

Line	Pipe diameter (mm)	Insulation thickness		Notes
		Standard conditions (Less than 30°C, RH 85%)	High humidity conditions (Over 30°C, RH 85%)	
		EPDM, NBR		
Liquid	Ø 6.35 ÷ 19.05	9	9	The pre-selected material must be able to withstand temperatures exceeding 120°C.
	Ø 12.70 ÷ 19.05	13	13	
Gas	Ø 6.35	13	19	
	Ø 9.52	19	25	
	Ø 12.70			
	Ø 15.88			
Ø 19.05				

5-7

Item	Unit	Standard Value	Notes
Density	g/cm ²	0.048 ÷ 0.096	KSM 3014-01
Dimensional variation due to temperature changes	%	≤ -5	
Moisture permeability	g/cm ²	≤ 0.005	
Thermal conductance	kcal/m·h·°C	≤ 0.032	KSL 9016-95
Moisture transpiration factor	ng/(m ² ·s·Pa)	≤ 15	KSM 3808-03
Moisture transpiration degree	{g/(m ² ·24h)}	≤ 15	KSA 1013-01
Formaldehyde release	mg/L	-	KSF 3200-02
Oxygen rate	%	≤ 25	ISO 4589-2-96

5-8

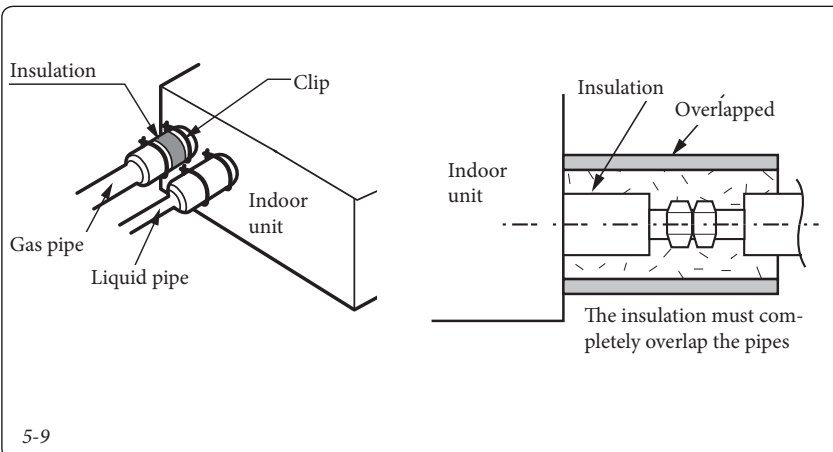

5-9

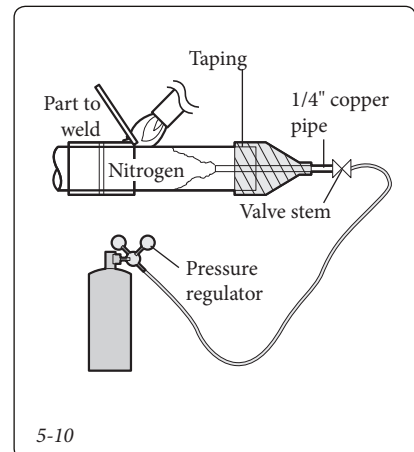

5-10

5.7 PRESSURE TESTING AND LEAK CHECK.

- To prevent foreign substances from getting into the circuit and to ensure the essential resistance to the pressures in play, it is fundamental that only an R-410A manometric unit be used.
- The pressure test must only be done using dry nitrogen.

Pressurise with dry nitrogen at 4.1 MPa via the liquid and gas pipe.	Should the unit be pressurised with nitrogen at more than 4.1 MPa, the pipes could be damaged. Pressing must be done using a pressure regulator.
Leave everything alone for at least 24 hours to check whether the pressure falls.	Pressure variations that can occur after pressurising with nitrogen must be checked using a pressure regulator.
If pressure decreases, it means there are leaks.	Should pressure decrease, a foaming solution must be applied to all the junctions to locate the leaks. Bubbles forming in the foaming solution pinpoint the location of the leaks, which must be eliminated before re-pressurising with nitrogen.
Maintain a pressure of at least 1.0 MPa and check for leaks again before putting the circuit under vacuum and drying it.	After having repaired any leaks, you must maintain pressure at 1.0 MPa at least and check for leaks again.

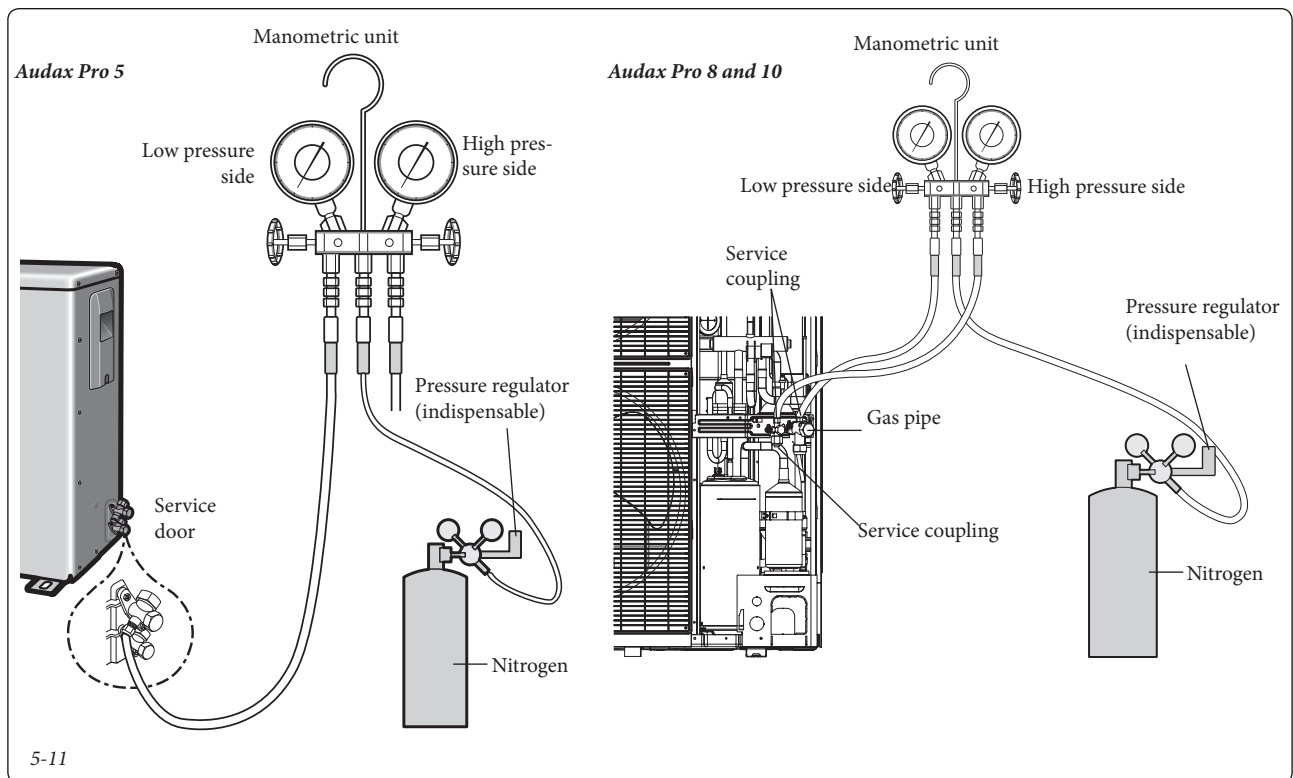

To check for leaks, you must use an approved foaming solution. Using a solution of water and normal soap risks damaging the flare nuts or triggering corrosive processes in the flare joints.

Attention: should a coupling be disconnected, the gas that escapes could cause injuries when coming into contact with people. Tighten the couplings as required to prevent these accidents.

5.8 PUTTING UNDER DRYING VACUUM.

- To prevent foreign substances from getting into the circuit and to ensure the essential resistance to the pressures in play, it is fundamental that only an R-410A manometric unit be used.
- Only a vacuum pump with a non return valve must be used to prevent the oil inside it from getting into the chiller circuit when it stops.
- Use a pump that is able to create a vacuum of up to 500 mTorr (66 Pa).
- Completely close the service valves on the gas and liquid side.

Attention: if pressure increases after an hour, this means that there is residual water inside the pipe and/or there are leaks.

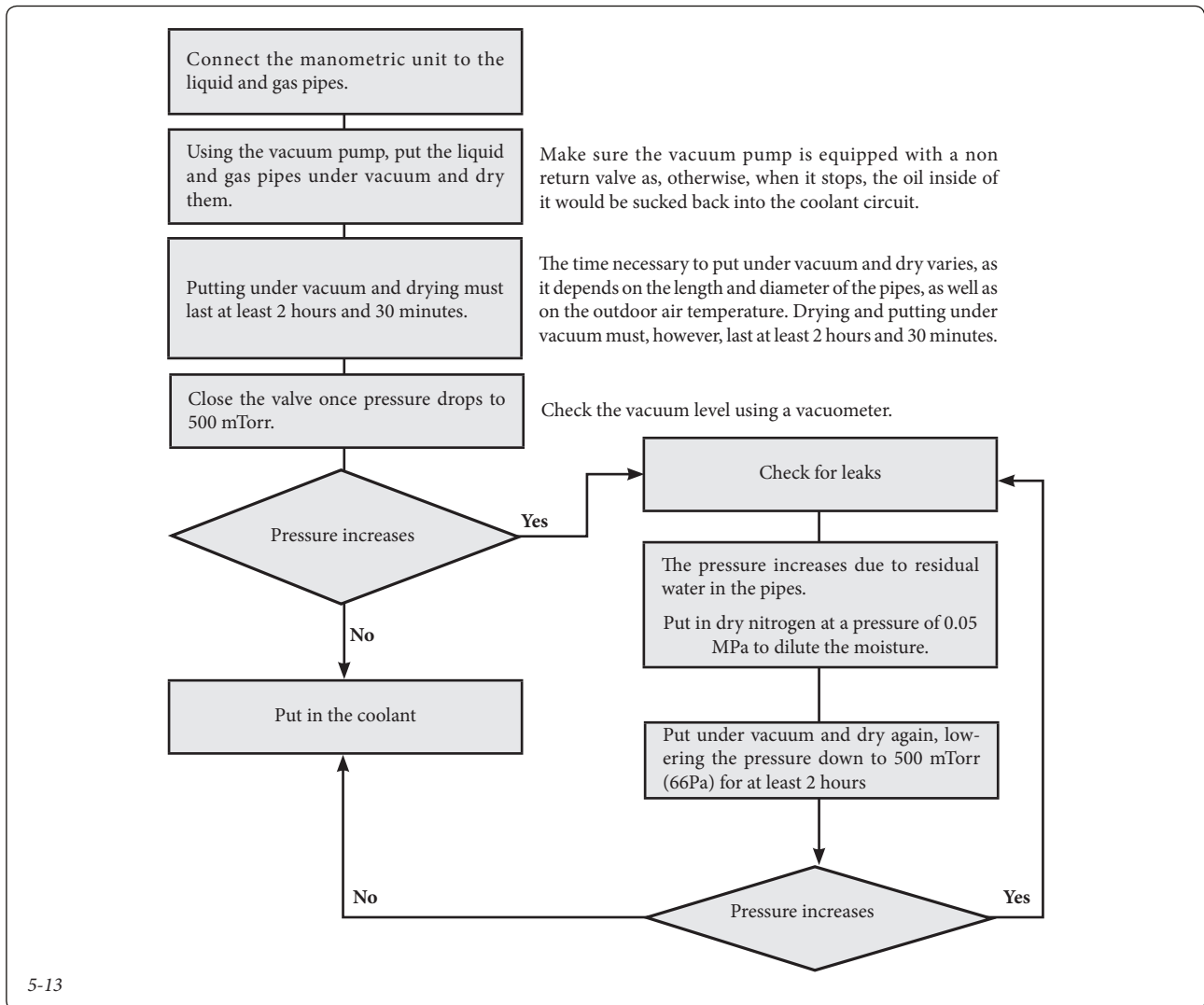
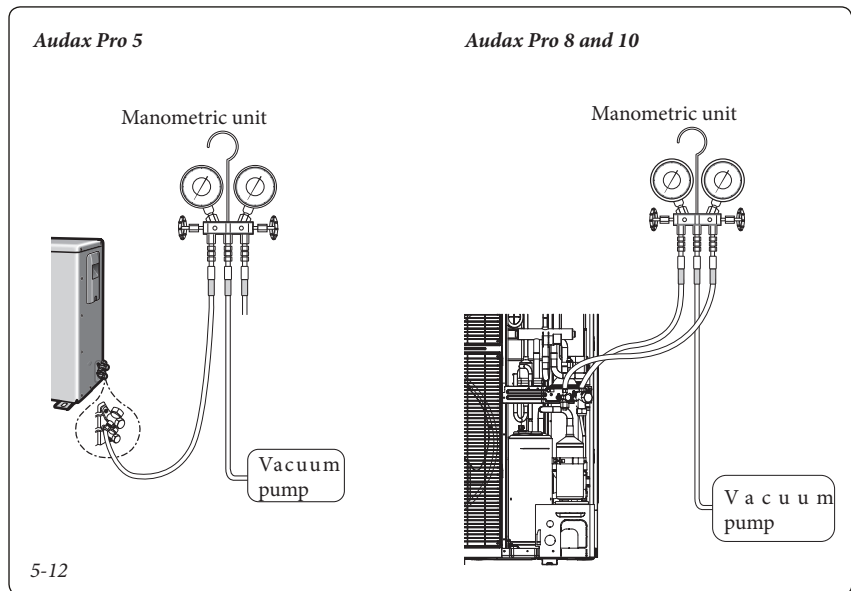

5.9 TOPPING UP THE COOLANT LOAD.

Below is the default factory base load:

- Audax Pro 5: 1.2 kg
- Audax Pro 8 and 10: 2.0 kg

The top-up depends on the total length and diameter of the pipes.

All the default factory loads are determined as follows, depending on the standard length of the pipes:

- Audax Pro 5: $\leq 5\text{m}$
- Audax Pro 8 and 10: $\leq 15\text{m}$

Should the pipes used be longer, the load must be topped up as follows.

The top-up amount depends on the total length of the liquid line.

$$(g) = \{(L1 - n) \times 20\} + \{(L2 - n) \times 50\}$$

Key:

- L1 - Total length of the $\varnothing 6.35$ liquid pipe, (m)
- L2 - Total length of the $\varnothing 9.52$ liquid pipe, (m)
- n - standard pipe length, see previously listed specific value

5.10 ADDING COOLANT.

As the outdoor unit comes already equipped with the base load, the amount to top-up depends on the total length and diameters of the liquid pipes.

Liquid line	$\varnothing 6.35$	$\varnothing 9.52$
Top-up (g)	20 g/m	50 g/m

Calculating the amount to top-up:

(Total length (m) of the $\varnothing 9.52$ pipes) \times 50 g
 + (Total length (m) of the $\varnothing 6.35$ pipes) \times 20g

Example:

$$20\text{ m} \times 50\text{ g/m} + 20\text{ m} \times 20\text{ g/m} = 1,400\text{ g}$$

5.11 PUTTING IN THE COOLANT.

R-410A is a blend of several coolants. For this reason, it must be put into the chiller circuit only in its liquid phase.

The amount of coolant to put in depends on the length and diameters of the liquid pipes. Using a scale is recommendable to put in the required amount of coolant.

5.12 IMPORTANT INFORMATION ON THE COOLANT USED

The coolant contained in this unit contains fluorinated greenhouse gases subject to the Kyoto Protocol. Therefore, it must not be released into the atmosphere.

Attention:

- Inform the user if the chiller circuit contains more than 5 tonnes of CO₂ equivalents of fluorinated greenhouse coolant. In this case, the system must undergo a leak check every 12 months, as required by regulation no. 517/2014.

Example: Audax Pro 2.0 kg of R-410A gas =
 2.0×2088 (GWP) = 4.18 tonnes of CO₂

N.B.: if there is a leak detection system, the minimum frequency of checks extends to every 24 months.

Checking for leaks must be done only by specialised personnel.

- In the previous situation (R-410A content greater than 5 tonnes of CO₂ equivalents), the installer (or the person responsible for final checks) must provide the user with a "unit record", on which to record all the information required by EU regulation 517/2014 of the European Parliament and Council dated 16 April 2014 on greenhouse gas management.

- Before putting in the coolant, you must check whether the tank in which it is contained has a float or not, and consequently position the tank itself (see fig. 5-14).

Introducing a load from a tank with float

Liquid loading can be done keeping the tank upright with the coupling facing upwards.

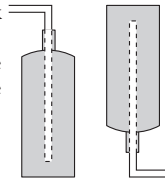

Introducing a load from a tank without float

Liquid loading can be done turning the tank upside down and keeping it upright with the coupling facing downwards.

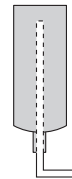

5-14

Contains fluorinated greenhouse gases subject to the Kyoto Protocol

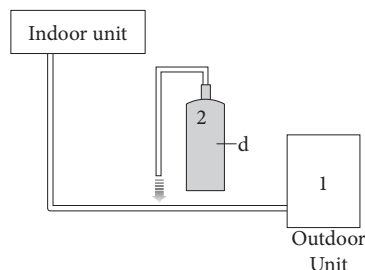

$$1 = \left(\begin{array}{c} a \\ | \\ b \end{array} \right) \text{ kg} \quad 1 + 2 = \left(\begin{array}{c} | \\ | \\ c \end{array} \right) \text{ kg}$$

Fill out with permanent ink.

1 Coolant load put into the unit at the factory.

2 Load top-up on-site.

1 + 2 Total coolant load.

On the coolant load identification label supplied with the unit.

- a - Coolant load put into the unit at the factory: shown on the identification plate.
- b - Load top-up on-site. (See the information provided regarding how to calculate the top-up amount.)
- c - Total coolant load.
- d - Coolant tank and pressure gauge load manifold.

Coolant type	GWP* value
R-410A	2088

GWP = Global Warming Potential

*) Based on 4th Assessment report of the Intergovernmental Panel on Climate Change - IPCC. Check for any updates.

5-15

5.13 TOPPING UP THE LOAD.

R-410A is a blend of several coolants. For this reason, it must be put into the chiller circuit only in its liquid phase.

The amount of coolant to put in depends on the length and diameters of the liquid pipes. Using an electronic scale is recommendable to put in the required amount of coolant.

Top-up must be done while the unit is operating in cooling

- Connect the manometric unit and bleed the air contained inside it.
- Open the service valve on the manifold liquid side and put in the coolant in liquid phase.
- If it is not possible to carry out or complete the top-up while the unit is not operating, using a button located on the outdoor unit PCB, you can complete the top-up.
- Topping up during operation in cooling (Fig. 5-16):

1 Open the valve on the gas side after 20 minutes of operation.

2 Open the valve on the pressure gauge manifold low pressure side to complete the top-up.

-Topping up during operation in central heating (Fig. 5-17):

1 Connect the manometric unit low side to the intake load coupling.

2 Press the top-up in central heating mode button.

3 Open the intake load coupling valve after 20 minutes of operation

4 Open the manometric unit low pressure side valve to complete the top-up

Attention: after having put in the coolant, you must completely open the liquid side valve and the gas side valve. (Allowing the system to operate when one of these valves is not completely open could damage important components).

5.14 SERVICE VALVE

- Closing the valve.

1 Remove the valve cover and turn the stem clockwise, using a hex key.

2 Tighten the stem until it is completely closed.

N.B.: do not force the stem and only use suitable tools. Otherwise, the contact surface between the shutter and its housing could be damaged, with subsequent coolant leakage.

If you notice coolant leaking, you must open the valve slightly, close it again and make sure there is no more leaking. If that is the case, the stem can then be tightened definitively.

3 Put the valve cover back on and tighten it as required.

- Opening the valve

1 Remove the valve cover.

2 Turn the stem anticlockwise, using a hex key.

3 Tighten the stem until it is completely closed.

4 Put the valve cover back on and tighten it as required.

Attention:

When you use the service coupling, you must also use a loading hose.

After tightening the cover, make sure no coolant leaks from it.

When opening/closing the valve, you must use a key and a counter key.

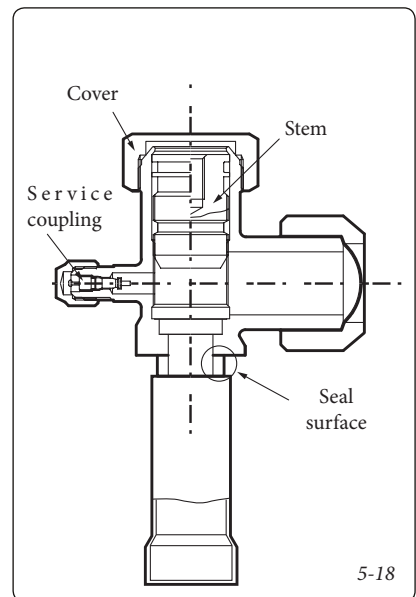
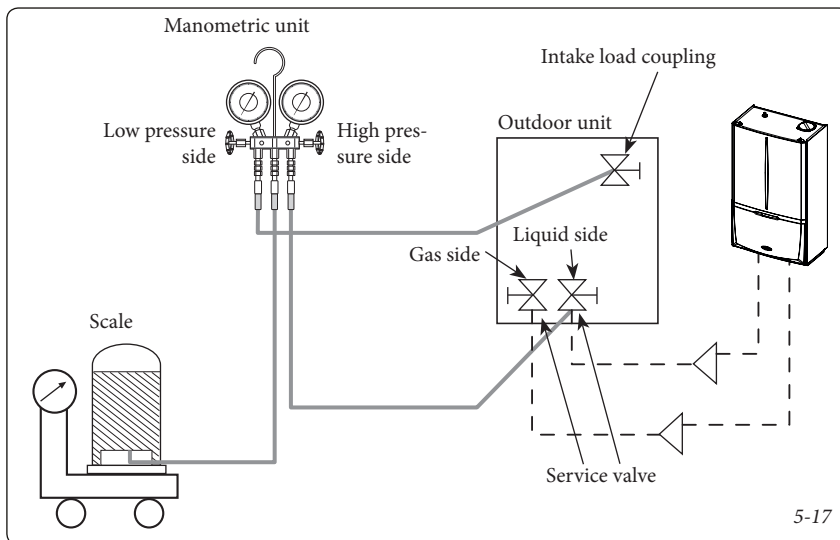
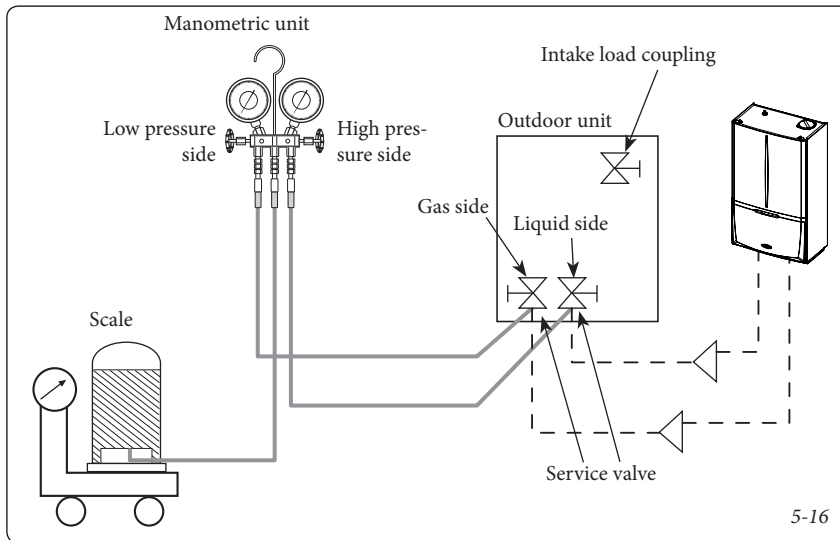

6 CHECKING THE EARTH- ING CONNECTION

Create a legally compliant earthing connection if the building does not have one or the one it has is not compliant. Whatever is needed to earth the electrical system is not included in the Immergas supply.

- 1 Get an earthing rod with the features shown in figure 6-1.
- 2 Connect the hose to the corresponding coupling.
 - Moist, compact ground is preferable to sandy or gravelly terrain, as the latter has a greater electrical resistance.
 - The earthing rod must be put in far from the mains or underground water or gas distribution structures, telephone networks or underground cables
 - The earthing rod must be put in at least two metres away from connection cables and lightning rods.
 - **N.B.:** the unit's earthing connection must not be made on telephone line earth connection cables.
- 3 Completely wrap the connection lines to the outdoor unit with electrical tape.
- 4 Connect a yellow/green cable to the earthing rod:
 - If necessary, the cable can be extended, welding it to an extension cord and carefully taping the junction (which, in any case, must never be buried).
 - Fasten the cable securely with hooks and clips
 - **N.B.:** the heavier the traffic in the area where the cable runs, the more securely fastened it must be.
- 5 Check earthing connection efficiency using a tester. If the resistance exceeds the necessary value, you must push the earthing rod further into the ground or add other earthing rods.
- 6 Connect the cable to the outdoor unit earthing terminal.

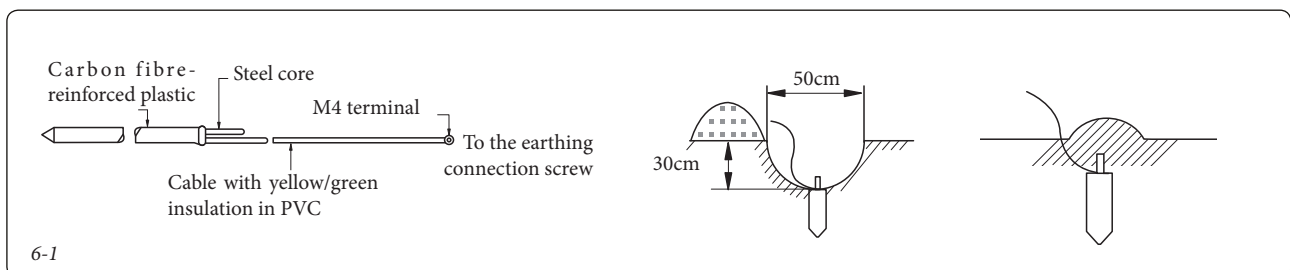

7 MICRO-SWITCH SETTING AND KEY FUNCTION

7.1 OPERATING TEST.

1 Check the supply voltage line between the units and the circuit breaker switch

- Mono-phase supply voltage: L, N

2 Check the CONTROL KIT.

- Make sure the power cables are connected properly (otherwise, the PCB could be seriously damaged).

- Make sure the temperature sensors, the drainage pump/hose and display are connected properly.

3 Use the K1 or K2 button on the outdoor unit PCB to start/stop the operating test.

KEY	Using the BUTTON	7-segment display
K1	Pressing it once: Operating test in Central heating	"E" "1" "BLANK" "BLANK"
	Pressing it twice: Operating test in Defrost	"E" "3" "BLANK" "BLANK"
	Pressing it 3 times: Completes the Operating Test	-
K2	Pressing it once: Operating test in Cooling	"E" "2" "BLANK" "BLANK"
	Pressing it twice: Completes the Operating Test	-
K3	Reset	
K4	Data display mode	Refer to the instructions that appear for the data display mode

Audax Pro 5

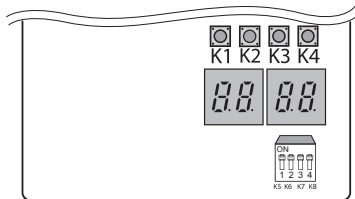

7-1

Audax Pro 8 and 10

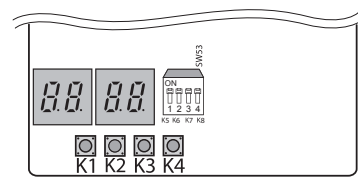

7.2 DATA DISPLAY MODE

Pressing the K4 button provides the information on the system status shown in figure 7-2.

No. of times it is pressed	Meaning of the instruction	Instructions				Unit
		Segment 1	Segment 2	Segment 3	Segment 4	
0	Communication status	Tens of Tx	Tx Unit	Tens of Rx	Rx Unit	
1	Controlled frequency	1	Hundreds	Tens	Unit	Hz
2	Current frequency	2	Hundreds	Tens	Unit	Hz
3	Type of Outdoor Unit (Mono/Split)	3	0	0	0 : split 1 : block	
4	Outdoor air sensor	4	+ / -	Tens	Unit	°C
5	Flow sensor	5	Hundreds	Tens	Unit	°C
6	PHE sensor (Eva)	6	+ / -	Tens	Unit	°C
7	Condenser sensor	7	+ / -	Tens	Unit	°C
8	Current	8	Tens	Unit	First decimal	A
9	Fan speed	9	Thousands	Hundreds	Tens	Rpm
10	Target flow temperature	A	Hundreds	Tens	Unit	°C
11	EEV valve	B	Thousands	Hundreds	Tens	pulses
12	Exchange power (not used)	C	0	0	0	kW
13	Protection controls	D	0 : cooling 1 : central heating	Protection control 0 : none 1 : antifreeze 2 : non-stop defrosting 3 : overload 4 : flow	Frequency status 0 : Normal 1 : Maintaining 2 : Lowering 3 : Upper limit 4 : Lower limit	-
14	PBA board heat sink temperature	E	Hundreds	Tens	Unit	°C
15	Number of connected indoor units	F	Hundreds	Tens	Unit	set
long-1	Main Micom version	Year (Hex)	Month (Hex)	Day (tens)	Day (unit)	-
long-1and 1	Inverter Micom version	Year (Hex)	Month (Hex)	Day (tens)	Day (unit)	-
long-1and 2	EEPROM version	Year (Hex)	Month (Hex)	Day (tens)	Day (unit)	-

7-2

7.3 MICRO-SWITCH SETTING.

Editing the micro-switch setting on the board, there are various operating modes available, as per figure 7-3 for Audax Pro 5 and figure 7-4 for Audax Pro 8 and 10.

KEY	ON (default)	OFF	Notes
K5	Automatic Orientation (the outdoor unit recognises the indoor unit address for random access).	Manual Orientation (the outdoor unit recognises the indoor unit address depending on the setting of the indoor unit rotary switch).	K5 must be ON
K6	Anti-snow accumulation mode: ON	Anti-snow accumulation mode: OFF	
K7			Not used
K8			Not used

7-3

KEY	ON (default)	OFF	Notes																
K5	Automatic Orientation (the outdoor unit recognises the indoor unit address for random access).	Manual Orientation (the outdoor unit recognises the indoor access address depending on the setting of the indoor unit rotary switch).	K5 must be ON																
K6	Base electric heater operation time: 15 min.	Base electric heater operation time: 20 min.	The base electric heater works below 0°C.																
K7	Anti-snow accumulation mode: ON	Anti-snow accumulation mode: OFF																	
K8	Base electric heater enabled	Base electric heater disabled																	
K9	Silent Operation	<table border="1"> <thead> <tr> <th>K9</th> <th>K10</th> <th>Mode</th> </tr> </thead> <tbody> <tr> <td>ON</td> <td>ON</td> <td>Silent operation disabled</td> </tr> <tr> <td>ON</td> <td>OFF</td> <td>Silent operation: Step 1</td> </tr> <tr> <td>OFF</td> <td>ON</td> <td>Silent operation: Step 2</td> </tr> <tr> <td>OFF</td> <td>OFF</td> <td>Silent operation: Step 3</td> </tr> </tbody> </table>		K9	K10	Mode	ON	ON	Silent operation disabled	ON	OFF	Silent operation: Step 1	OFF	ON	Silent operation: Step 2	OFF	OFF	Silent operation: Step 3	
		K9	K10	Mode															
ON	ON	Silent operation disabled																	
ON	OFF	Silent operation: Step 1																	
OFF	ON	Silent operation: Step 2																	
OFF	OFF	Silent operation: Step 3																	
K10																			
K11		X	Not used																
K12		X	Not used																
K13	Total current absorption control	<table border="1"> <thead> <tr> <th>K13</th> <th>K14</th> <th>Mode</th> </tr> </thead> <tbody> <tr> <td>ON</td> <td>ON</td> <td>Total absorption limit: 1_Down</td> </tr> <tr> <td>ON</td> <td>OFF</td> <td>Total absorption limit: 1_Down_OP1</td> </tr> <tr> <td>OFF</td> <td>ON</td> <td>Total absorption limit: 1_Down_OP2</td> </tr> <tr> <td>OFF</td> <td>OFF</td> <td>Total absorption limit: 1_Down_OP3</td> </tr> </tbody> </table>		K13	K14	Mode	ON	ON	Total absorption limit: 1_Down	ON	OFF	Total absorption limit: 1_Down_OP1	OFF	ON	Total absorption limit: 1_Down_OP2	OFF	OFF	Total absorption limit: 1_Down_OP3	
		K13	K14	Mode															
ON	ON	Total absorption limit: 1_Down																	
ON	OFF	Total absorption limit: 1_Down_OP1																	
OFF	ON	Total absorption limit: 1_Down_OP2																	
OFF	OFF	Total absorption limit: 1_Down_OP3																	
K14																			
K15		X	Not used																
K16		X	Not used																

7-4

8 PUMP DOWN PROCEDURE.

8.1 PURPOSE OF PUMP DOWN.

Pump down is used to accumulate coolant in the outdoor unit before disconnecting the chiller lines.

8.2 PRECAUTIONS TO TAKE BEFORE PERFORMING PUMP DOWN.

Due to the compact nature of its shape, the unit contains a small load of coolant

Before performing pump down, most of the load can be transferred to an empty tank.

Attention: the maximum amount of coolant that can be accumulated in the outdoor unit is 5 kg.

Accumulating larger quantities of coolant risks causing the compressor to stop or burn out.

8.3 PRECAUTIONS TO TAKE BEFORE PERFORMING PUMP DOWN.

- 1 Close the manometric unit.
- 2 Close the liquid service valve.
- 3 Press the K2 button on the outdoor unit PCV three times; this makes the (H₁) indication appear on the board LED display
- 4 Keep an eye on the manifold low pressure gauge while the compressor is running.
- 5 When the indication on said pressure gauge goes below 0 MPa (0 kgf/cm²) eff., close the gas service valve and abandon pump down (pump down can be abandoned by pressing the K2 button again or by pressing the K3 button to reset).

Attention: Coolant can only be transferred to appropriate tanks. Otherwise, explosions can occur with subsequent damage to things and injury to people.

N.B.: Repositioning the Air-Water heat pump.

- If the unit must be repositioned, do as follows:
- Perform pump down (put the above procedure in action).

- Transfer as much coolant as possible to an external tank in order to accumulate no more than 5 kg in the outdoor unit (see parag. 8.4 for details on coolant loads)
- Disconnect the power cable.
- Disconnect the connection cable between the outdoor and indoor unit.
- Disconnect the pipes from the indoor unit flared couplings.
- To prevent foreign objects from getting in, immediately plug the indoor unit couplings and the pipes they were connected to with vinyl caps.
- Disconnect the pipes from the external unit flared couplings. To prevent foreign objects from getting in, immediately plug the outdoor unit couplings and the pipes they were connected to with vinyl caps.
- Be careful not to damage the couplings and the terminal boards.
- Move the indoor and outdoor units to their respective new positions.
- Disassemble the indoor unit securing devices and reassemble them in the new position.

8.4 TRANSFERRING THE COOLANT INTO AN EXTERNAL TANK BEFORE PERFORMING PUMP DOWN.

Do as follows before performing pump down if the load quantity exceeds the maximum quantity that can be accumulated in the outdoor unit.

- 1 Get an empty tank for R-410A, a scale and a pressure gauge manifold.
- 2 Identify the load quantity contained in the chiller circuit.
- 3 Connect the tank to the outdoor unit and run approximately 50% of the indoor unit in cooling.
- 4 After about 10 minutes, check the pressure on the high side on the manifold pressure gauge. If it exceeds 3.0 MPa (30.59 kgf/cm²) eff., you must reduce the quantity of the indoor units in order to bring it back under 3.0 MPa (30.59 kgf/cm²).
- 5 As soon as the pressure goes below 3.0 MPa (30.59 kgf/cm²) eff., open the manometric unit 2 tap, connected to the liquid side. Then open the receiving tank valve to allow the coolant to flow.
- 6 Using the scale, check the quantity of coolant that has been transferred to the tank. Close the liquid valve and disconnect the pressure gauge manifold as soon as the desired quantity has been reached.
- 7 The quantity of transferred coolant should correspond to 50% of the entire load contained in the chiller circuit.
- 8 The amount of the load remaining in the circuit must not exceed the quantity that can be accumulated in the outdoor unit.

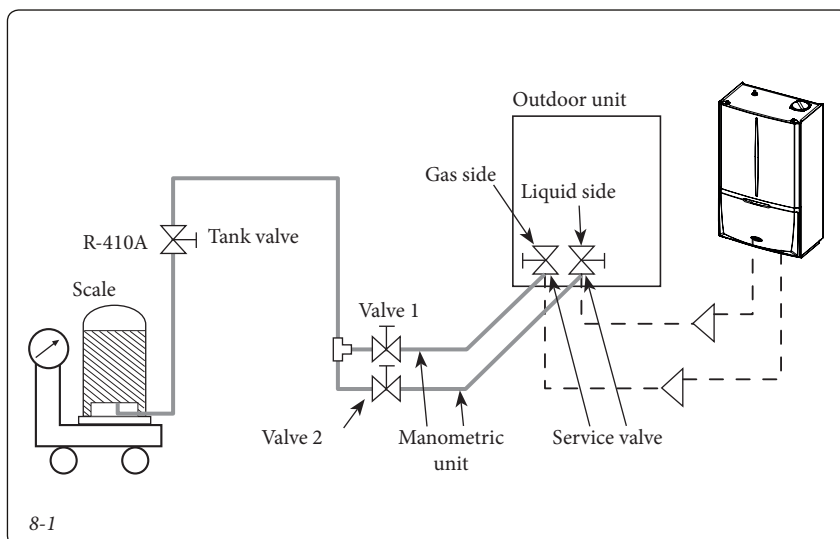

8.5 RECOVERING LARGE QUANTITIES OF COOLANT.

Should recovering the coolant be difficult due to the large amount in play:

- 1 Get an empty tank for R-410A, a scale and a manometric unit.
- 2 As shown in the figure, connect the central coupling of the manometric unit to the coolant tank and the side couplings of the manifold itself to the outdoor unit service valves (leaving the tank valve and the low side service valve closed and leaving the high side service valve open).
- 3 Start the coolant transfer procedure by pressing the K2 button three times.
- 4 After 10 minutes, open the tank valve to transfer the coolant.
- 5 Close the tank valve as soon as the desired quantity of coolant has been transferred.
- 6 Immediately close the liquid side service valve. Also close the gas service valve as soon as the low side pressure goes below 0.
- 7 Press the reset button to abandon the Stop procedure.

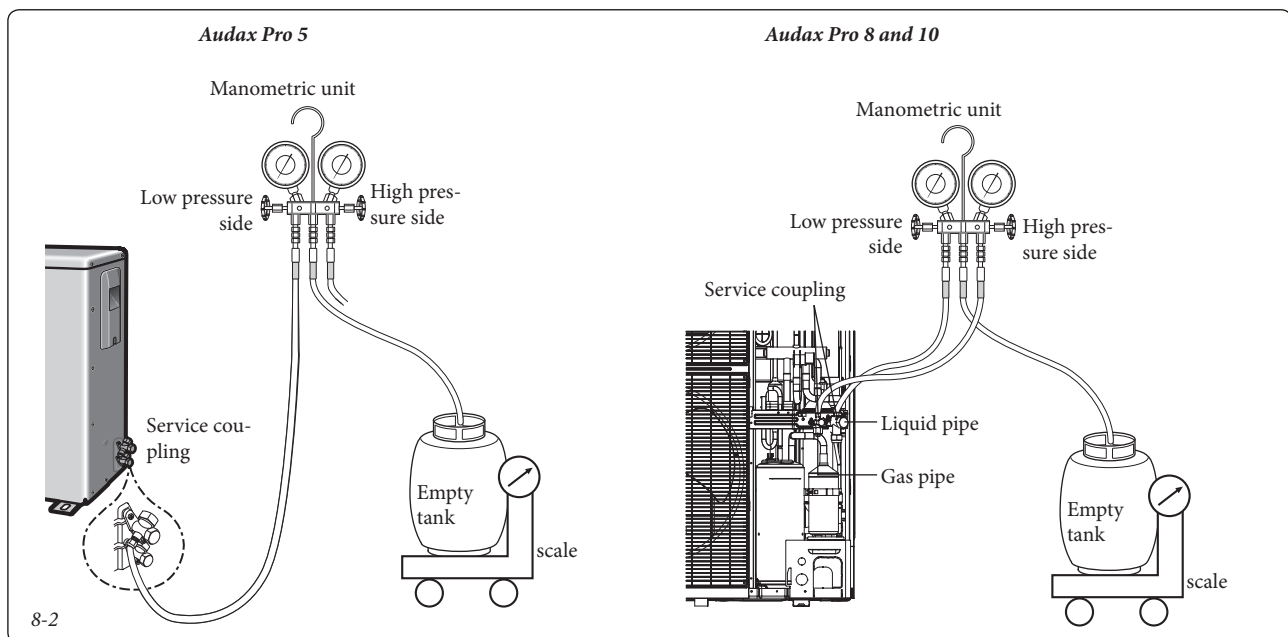

9 COMPLETING INSTALLATION.

9.1 CHECKS AT THE END OF INSTALLATION.

Once installation is complete, check the following:

Installation	Outdoor unit	<p>Check the conditions of the inner and outer surface.</p> <p>Can there be short circuits?</p> <p>Is the installation position well-ventilated and are the required spaces free?</p> <p>Are the units secured well?</p>
	Indoor unit	<p>Check the conditions of the inner and outer surfaces.</p> <p>Is the installation position well-ventilated and are the required spaces free?</p> <p>Check installation fastening and horizontality.</p>
Coolant pipes		<p>Are the pipe lengths and drops between the units within the required limits?</p> <p>Are the pipes duly insulated?</p> <p>Was the load top-up correctly weighed?</p>
Condensate drain pipes		<p>Check the drain pipes on the indoor and outdoor units.</p> <p>Has drainage system operation been checked?</p> <p>Are the drain pipes duly insulated?</p>
Electrical connections		<p>Has the earthing connection been made using procedure 3 and in compliance with the dictates of the standards in force in the installation site?</p> <p>Were 2-conductor cables used?</p> <p>Are the cable lengths within the required limits?</p> <p>Is the cable layout correct?</p>

9-1

9.2 FINAL CHECKS AND OPERATING TEST

Before starting the checks and operating tests, the outdoor unit must be powered at least three hours before the operating test begins in order to appropriately pre-heat the compressor. If the compressor is not adequately pre-heated, 'CH' may appear on the outdoor unit PCB display.

Checks to carry out before the operating test.

- 1 Check the indoor and outdoor unit power and communication cables
- 2 Check the supply voltage between the outdoor unit and the electrical panel.
- 3 Using a voltmeter, make sure the supply voltage is at 220 V - 240 V~ or at / 380-415V~.
- 4 Once enabled, the outdoor unit searches for the connected indoor units and the options.

Operating test

- 1 Activate the unit using the MODE button or the control system.
 - Activate all the indoor units using the MODE BUTTON located on the printed circuit

board on the outdoor unit control board.

- Using the control system, activate all the indoor units separately.
 - Observe how the compressor behaves at start-up. If it emits a rumbling sound, stop operation immediately.
- 2 Check the operating status of the indoor and outdoor units.
 - Check the air flow from the indoor units in central heating and cooling.
 - For every internal unit, check: air flow direction and speed.
 - Check for any strange noises from the internal units and/or outdoor unit.
 - 3 Abandon the operating test.
 - 4 Explain the heat pump management modes to the user according to the instructions in the user manual.

10 YEARLY UNIT CHECK AND MAINTENANCE.

The following checks and maintenance should be performed at least once a year.

- Visually check for water leaks or oxidation from/on connections.
- Visually check that the safety and control devices have not been tampered with and/or short-circuited.
- Check the condition and integrity of the electrical system and in particular:
 - power cables must be inside the fairleads;
 - there must be no traces of blackening or burning.
- Check ignition and operation.
- Check the operation of the appliance control and adjustment devices and in particular:
 - system regulation probes intervention;
- Clean the coil.

IMPORTANT NOTE: in addition to yearly maintenance, you must also check the thermal system and energy efficiency, with the frequency and procedures that comply with the technical regulations in force.

11 TROUBLESHOOTING.

Attention:

- Incorrectly managing thermostats, safety valves and/or other types of valves can cause the tank to break. Every operation on the unit must be done scrupulously following the instructions that concern it.
- The electrical supply voltage must always be cut off before cutting off the hydraulic supply.
- Regularly check safety valve operation, making it open to make sure water flows out with no problem.
- The electrical connections and any work on the electrical components must be done solely by qualified electricians.
- The hydraulic connections and any work on the hydraulic components must be done solely by qualified installers.
- The components used as spare parts must be approved by Immergas

11.1 FAULT CODES.

Every problem that presents itself during operation is highlighted by an error code that appears on the main board of the outdoor unit or on the hydronic unit display.

Code	Explanation
101	CONTROL KIT/OUTDOOR UNIT wiring error
201	CONTROL KIT/OUTDOOR UNIT communication error (coupling error)
202	CONTROL KIT/OUTDOOR UNIT communication error (3 min.)
203	Communication error between INVERTER and MAIN MICOM (6 min.)
221	OUTDOOR UNIT temperature sensor error
231	Condensation temperature sensor error
251	Flow temperature sensor error
320	OLP sensor error
403	Ice detected on the compressor during operation in cooling
404	OUTDOOR UNIT overload prevention trip (at Safety device start-up, operation ? normal)
416	Compressor flow overtemperature
419	OUTDOOR UNIT EEV operation error
425	One of the supply voltage phases has fallen (only for three-phase models)
440	Operation in central heating stopped (outdoor temperature > 36°C)
441	Operation in cooling stopped (outdoor temperature < 9°C)
458	OUTDOOR UNIT fan 1 error
461	Compressor start-up error [Inverter]
462	Absorption error [Inverter]/PFC overcurrent error
463	OLP overheating
464	IPM overcurrent error [Inverter]
465	Compressor voltage limit error
466	LINK in CC Over/Undervoltage error
467	Compressor rotation error [Inverter]
468	Current sensor error [Inverter]
469	LINK in CC voltage sensor error [Inverter]
470	EEPROM reading/writing error
471	OTP error [Inverter]
474	IPM (IGBT Module) or PFCM temperature sensor error
475	OUTDOOR UNIT fan 1 error
484	PCF overload error
485	Incoming current sensor error
500	IPM overload
554	Coolant leak error

Follow us

Immergas Italia



immergas.com

Immergas S.p.A.
42041 Brescello (RE) - Italy
Tel. 0522.689011
Fax 0522.680617

Certified company ISO 9001

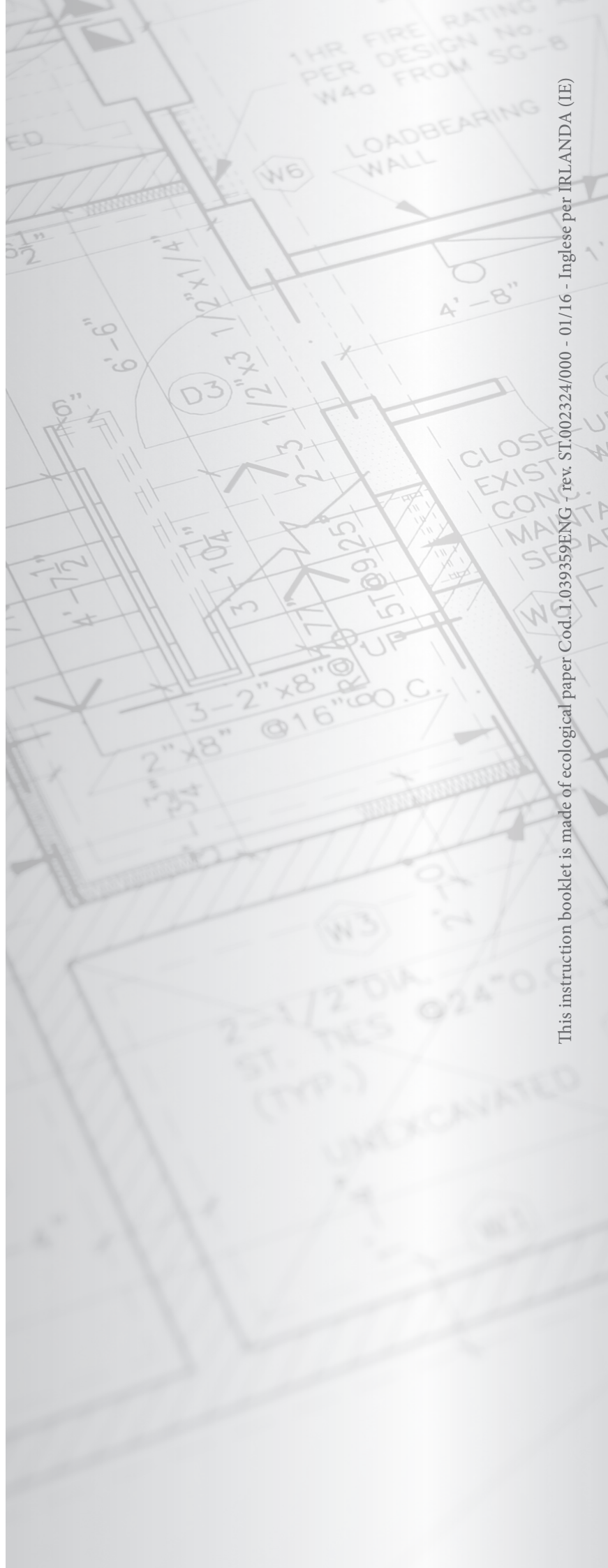

This instruction booklet is made of ecological paper Cod. I.039359ENG - rev. ST.002324/000 - 01/16 - Inglese per IRLANDA (IE)