

LIGHT COMMERCIAL



1964-2014 50th ANNIVERSARY



NEW RANGE

VICTRIX PRO RANGE

Light commercial
condensing boilers





 **iMMERGAS**





50th

1964 2014

Immergas. Our long story teaches us always to look to the future.

The **5th of February 1964** saw the birth of Immergas out of an inescapable desire to come up with ideas and reliable products in the Italian style. Products designed to last that would improve people's lives. Today, for the thousands of engineers and employees who work and cooperate with us, nothing has changed. We are present in over 40 countries with 9 branches in Europe and one in China, we have partnerships with the most important distribution companies across the globe, yet **we keep on investing** in facilities, plants, and technologies with the selfsame spirit.

On account of the same business idea we insist on developing our designs and **paying more attention to the environment and consumption** through new technologies. This same enthusiasm means that we continue to reaffirm day after day the importance of collaborating with those who sell, install and offer assistance to look after Immergas products and above all our end customers. **Nowadays, just like 50 years ago**, our profoundest thoughts go out to them with the intention of contributing to a better future made up of comfort, safety, reliability, and environmental friendliness.



VICTRIX PRO range

Wall-hung modular condensing boilers for heating only

HIGH HEATING OUTPUT, WIDE MODULATING RATIO AND HIGH EFFICIENCY

Modularity and high output make the new **VICTRIX PRO** range ideal for the central heating **systems of residential and commercial buildings**, but the new design and compact dimensions make them suitable for private homes as well.

All models can be installed either **indoors or outdoors**, on a wall or on a new free standing support frame, and offer excellent solutions to designers who have to install central heating systems in buildings where **little space is available**. The **modularity of installation** makes it possible to place up to **5 generators side by side**, and the exceptional power modulating ratio is up to 1÷10. With these features, VICTRIX PRO boilers are **perfect for energy upgrading** of any existing or new buildings **thanks also to the possibility of connecting them to renewable energy sources such as solar heating**.

The range includes:

VICTRIX PRO 35 1 I
VICTRIX PRO 55 1 I

VICTRIX PRO 80 1 I

VICTRIX 100 1 I
VICTRIX PRO 120 1 I

The names of the boiler models indicate the maximum boiler heating outputs operating with delivery and return temperature 50/30 °C.



VICTRIX PRO RANGE

A WIDE RANGE

From 35 kW to 120 kW output

REDUCED CONSUMPTION

Very high modulation range
up to 1÷10

CASCADE INSTALLATION OF UP TO 5 BOILERS

INDOOR AND OUTDOOR INSTALLATION

NEW REMOTE CONTROL



BEYOND TECHNOLOGY, SUPPORT FOR PROFESSIONALS

To provide professionals with all necessary information and get the most out of the new commercial light boiler solutions, Immergas has a technical team always available to provide guidance or regulations for the design and layout of hydraulic and electrical plant schemes.





.01 NEW CONTROL PANEL

The new vertically sliding door protects the display and the board. The boiler controls are user friendly thanks to simple buttons and a backlit display.

HIGH SEASONAL EFFICIENCY

The modulation range 1:10 makes it possible to optimize generator function even with reduced heating requirements (for example, during mid-seasons or in case of multi thermal zones systems).

NEW REMOTE CONTROL

For systems in which remote control is a desirable feature, an optional kit is available to communicate exclusively with the cascade and zone regulator (see page 11) so as to control the central heating system.

COMPLETE RANGE OF OPTIONALS

With VICTRIX PRO the installer and designer can avail themselves of all the optionals to complete the central heating system from the hydraulic components, the thermoregulation devices, the flue systems to condensate neutralisers.

.02



.02 MODULAR INSTALLATION

Considering that up to 5 boilers (with the relative optionals) can be installed hydraulically in cascade, it has never been so easy to reach powers even as high as 700 kW.

INSTALLATION ON SUPPORTING FRAME

VICTRIX PRO can be installed on a modular type supporting frame either individually or in batteries of up to 5 boilers with linear or in a back-to-back arrangement in case of space constraints. The frames are equipped with a supporting collar for the hydraulic manifolds and can be fastened to the wall or floor with special anchor bolts. The frames are also approved for outdoor installation.

IDEAL ALSO FOR OUTDOOR INSTALLATIONS

Thanks to the high degree of electrical protection (IPX5D) and cataphoresis treatment on the frame, VICTRIX PRO can also be installed outdoors.



.03



.03 MODULE FOR CONDENSATION IN STAINLESS STEEL

The range is equipped with condensation modules in which the hydraulic circuit is made of stainless steel (for the VICTRIX PRO 35 and 55 1 l version, the outer shell is made from a composite material).

It is essential that the central heating system is thoroughly cleaned and flushed when fitting a VICTRIX PRO; it is important to use the cleaning agent and inhibitor in order to preserve the heating system (pipes, heating exchanger, etc.).

.04



.04 COMBUSTION SYSTEM AND TOTAL PREMIXING

Research and development in the sector of combustion system has enabled us to achieve a modulation field raised from 10 to 100% of the thermal power on the entire range. In addition, the generators can function with either national gas or LPG.

INTEGRATED TRAP FOR CONDENSATION DISPOSAL

A special trap built into the boiler collects the condensation and ensures its regular drainage; the trap is connected to a polypropylene hose which will not be damaged by the action of the condensate.

On the outside of the generator, the acid condensation should be discharged according to the regulations in force and good technique.



LOW EMISSIONS OF NO_x AND CO POLLUTANTS

The range has obtained a class 5 rating in terms of pollutant emissions, making it an excellent choice for installation in buildings that require high energy performance and low environmental impact.

OPTIMUM CONTROL OF ADJUSTMENT

The inclusion of two NTC probes (in the delivery and return of the system) guarantees optimum control of the operating temperature.

PRODUCTION OF DOMESTIC HOT WATER IS ALSO INTEGRATED WITH SOLAR SYSTEMS

For both individual boilers and battery installations, VICTRIX PRO can be combined with Immergas solar solutions for the production of domestic hot water, in particular to the storage tanks units with capacities of 200, 300, 500, 1000, 1500 and 2000 liters.





.05 EASY CONTROL OF BOILERS IN CASCADE INSTALLATIONS

The cascade and zone regulator makes it possible to manage, control and program the sequence of operations of the boilers connected, deciding which boiler to start, the output required and the operating sequence depending on the request of the heating system.

CONTROL OF SOLAR SYSTEMS FOR THE PRODUCTION OF DOMESTIC HOT WATER

The cascade regulator serves for easy management of a thermal solar system for the production of D.H.W., adding special control probes (see page 17).

MAIN FEATURES

Electrical connection to the main boiler	Temperature setting	No. of boilers manageable	Manageable zones	Connection in series	Connection to a solar system
2 BUS cables: max distance 50 meters	Room heating: Comfort, less antifreeze D.H.W. setting	8	3 (2 of which mixed) + 1 boiler unit	Up to 5 cascade regulators of which only the main regulator (master) will be connected on the boiler	Possibility of setting solar circuit parameters without the need of extra control units

.06



.06 REMOTE CONTROL OF HEATING SYSTEM

The cascade and zone regulator permits use of the remote control kit for connection **via ethernet to a company network**, or through a **router/modem to an ADSL line** that can be connected to the outside via Internet Explorer with relative IP address.

GSM/GPRS CONNECTION

If no ADSL line is available, it is possible to connect the remote control gateway to a router (modem with SIM card that operates as a GSM router – not supplied by Immergas) through which it is possible to use the GSM/GPRS for connection to the outside.



Technical data	Unit of measurement	VICTRIX PRO 35 1 I	VICTRIX PRO 55 1 I	VICTRIX PRO 80 1 I	VICTRIX PRO 100 1 I	VICTRIX PRO 120 1 I
Code	N.G. L.P.G.	3.024488 3.024488GPL	3.024489 3.024489GPL	3.024490 3.024490GPL	3.024491 3.024491GPL	3.024492 3.024492GPL
CE certificate		0051CO4405	0051CO4405	0051CO4405	0051CO4405	0051CO4405
Maximum heat output	kW	34,9	51,3	75,3	92,3	114,1
Minimum heat output	kW	3,9	5,5	7,6	9,4	11,4
Maximum nominal heat output (80/60 °C)	kW	34,0	49,9	73,0	90,0	111,0
Maximum nominal heat output (50/30 °C)	kW	37,3	54,8	80,3	98,8	121,7
Minimum nominal heat output (80/60 °C)	kW	3,4	5,0	7,2	9,0	11,0
Minimum nominal heat output (50/30 °C)	kW	3,7	5,5	8,1	10,1	12,2
Efficiency at nominal heat output (80/60 °C)	%	97,3	97,3	97,0	97,5	97,3
Efficiency at minimum heat output (80/60 °C)	%	86,3	91,2	94,8	96,2	96,4
Efficiency at nominal heat output (50/30 °C)	%	107,0	106,8	106,6	107,0	106,7
Efficiency at minimum heat output (50/30 °C)	%	94,7	99,7	106,9	107,4	107,2
Efficiency at nominal heat output (40/30 °C)	%	107,3	107,4	107,3	107,4	107,2
Efficiency at minimum heat output (40/30 °C)	%	100,2	103,5	107,2	107,6	107,5
Stack losses with burner on 100% Pn (80/60 °C)	%	1,6	1,8	2,2	1,9	2,0
Stack losses with burner OFF	%	0,04	0,03	0,01	0,01	0,01
Casing losses with burner ON 100% Pn (80/60 °C)	%	1,1	0,9	0,8	0,6	0,7
Casing losses with burner OFF	%	0,44	0,30	0,34	0,41	0,28
NOx class		5	5	5	5	5
Weighted NOx	mg/kWh	25,0	39,0	25,0	20,0	33,0
Weighted CO	mg/kWh	8,0	15,0	16,0	12,0	18,0
Gas flow rate to burner at max. and min. heat output with methane (G20)	m³/h	3,70 - 0,42	5,44 - 0,58	7,96 - 0,80	9,77 - 0,99	12,07 - 1,21
Maximum fan available head (max/min)	Pa	50/1	110/1	230/6	208/4	145/5
Flue exhaust mass flow rate at nominal heat output (G20)	Kg/h	55	81	115	144	178
CO ₂ at nominal/minimum heat output (G20)	%	9,40 / 9,10	9,40 / 9,10	9,85 / 8,85	9,60 / 8,90	9,60 / 9,00
CO at 0% of O ₂ (G20)	ppm	84	157	229	180	190
Maximum fume temperature	°C	48	52	62	54	56
Maximum operating temperature	°C	90	90	90	90	90
Heating system adjustable temperature	°C	20 - 85	20 - 85	20 - 85	20 - 85	20 - 85
Maximum operating pressure of heating circuit	bar	4,4	4,4	4,4	4,4	4,4
Electric power	V/Hz	230 - 50	230 - 50	230 - 50	230 - 50	230 - 50
Max power supply	W	140	195	290	370	440
Electrical insulation rating	IP	X5D	X5D	X5D	X5D	X5D
Gross weight	kg	51,2	51,4	81,0	95,9	102,5
Boiler water capacity	litres	2,8	2,8	4,0	10,1	11,7



Dimensions and connections

VICTRIX PRO 35-55

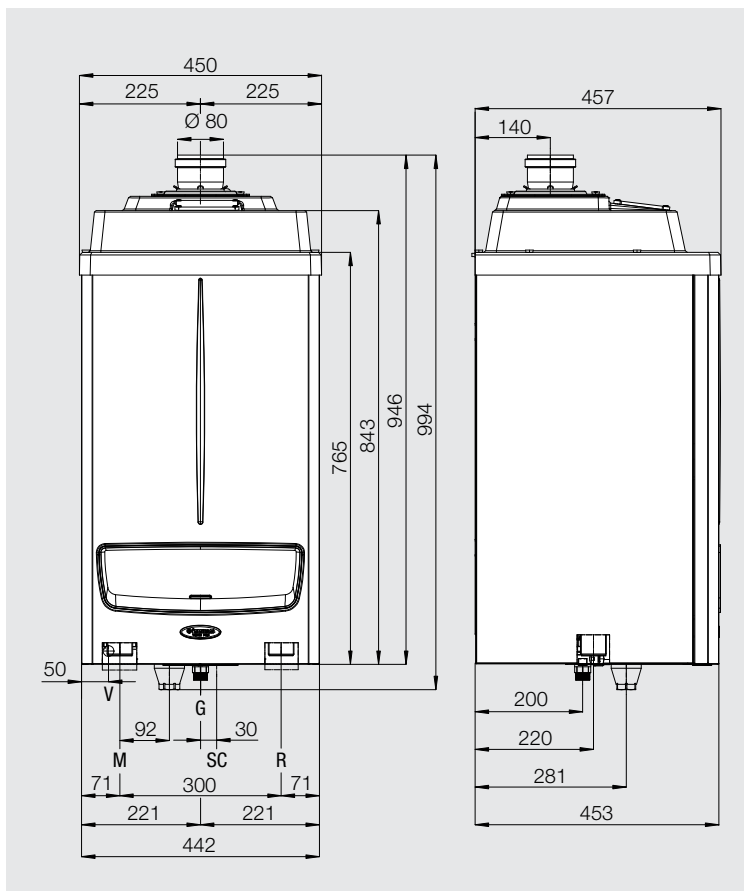

Key

- V** Electrical connection
- G** Gas supply
- SC** Condensate drain (minimum internal diameter Ø 13 mm)
- M** System delivery
- R** System return

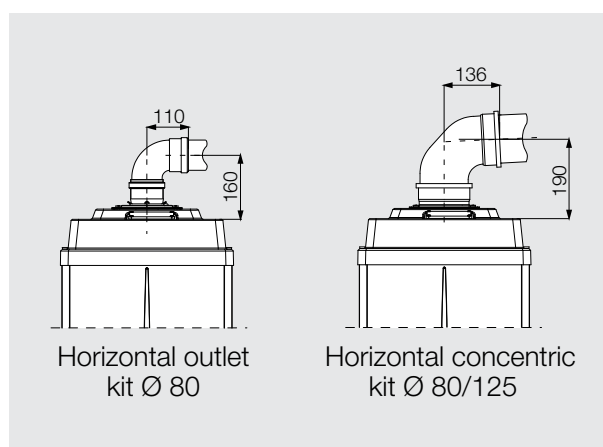

Flow rate/head graph

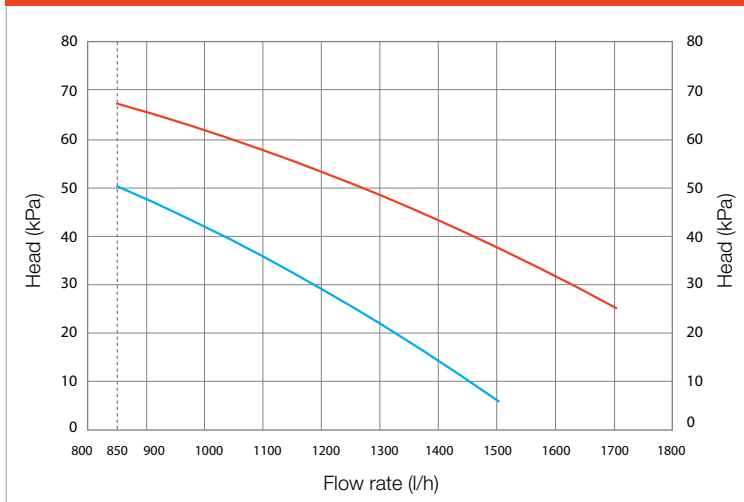

Hydraulic connections

Gas	Heating		Condensate drain
G	R	M	SC
¾"	1 ½"	1 ½"	25 mm

Available head in the system:

- at top speed
- at second speed



Dimensions and connections

VICTRIX PRO 80

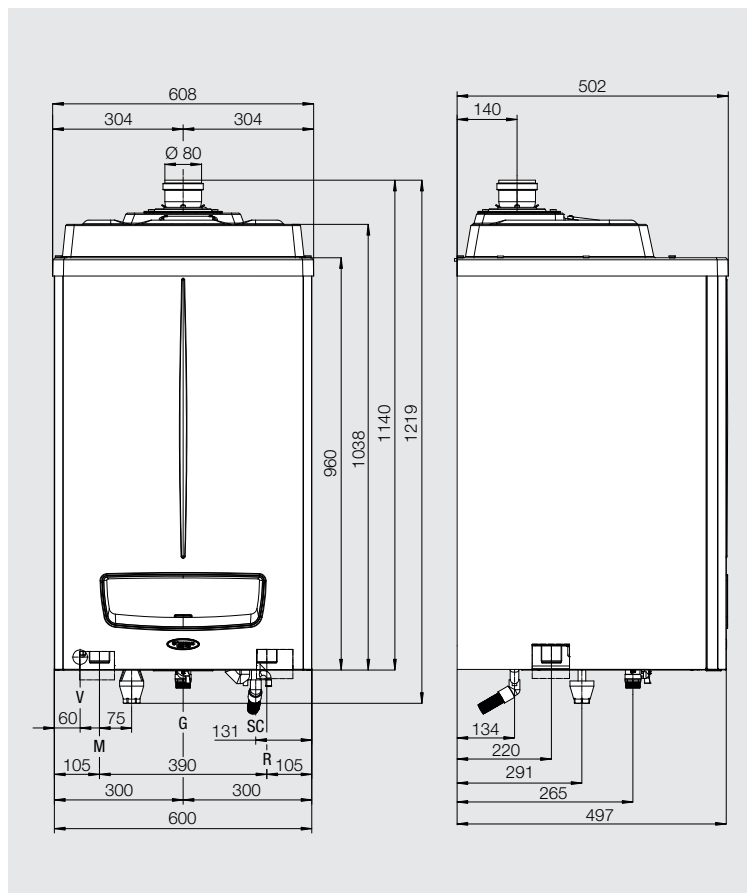

Key

- V** Electrical connection
- G** Gas supply
- SC** Condensate drain (minimum internal diameter Ø 13 mm)
- M** System delivery
- R** System return

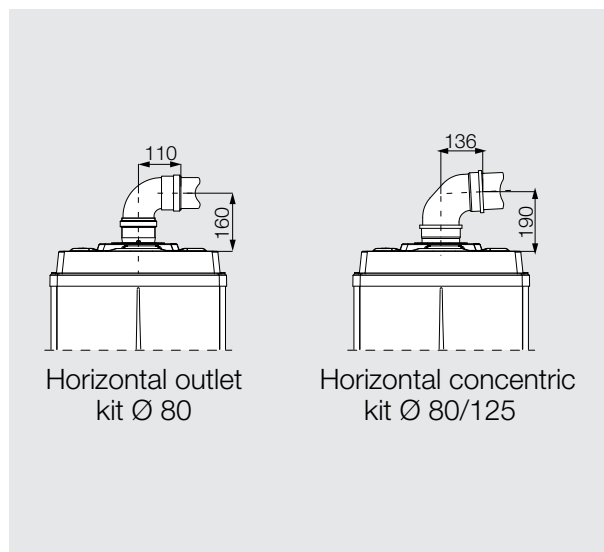

Flow rate/head graph

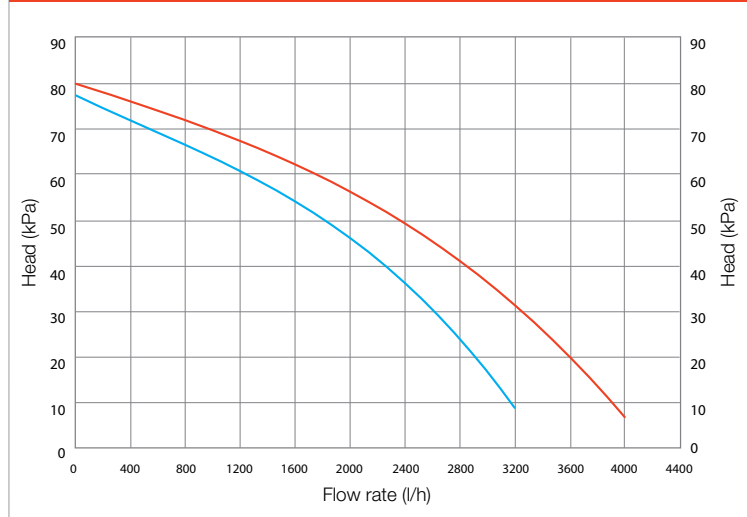

Hydraulic connections

Gas	Heating		Condensate drain
	R	M	
G ¾"	1 ½"	1 ½"	SC 25 mm

Available head in the system:

- at top speed
- at second speed



Dimensions and connections

VICTRIX PRO 100-120

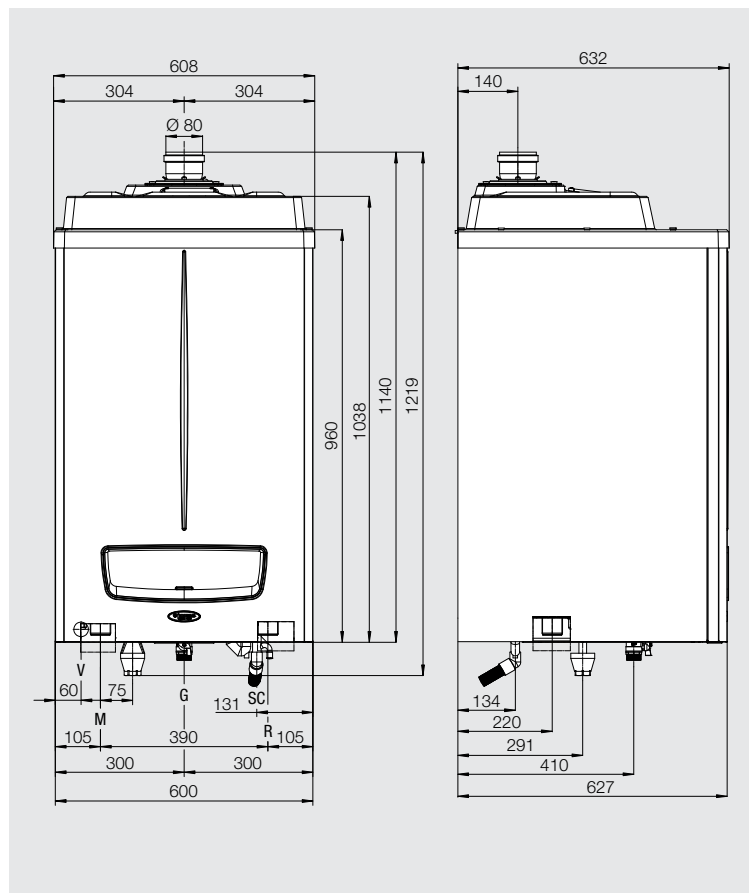

Key

- V** Electrical connection
- G** Gas supply
- SC** Condensate drain (minimum internal diameter Ø 13 mm)
- M** System delivery
- R** System return

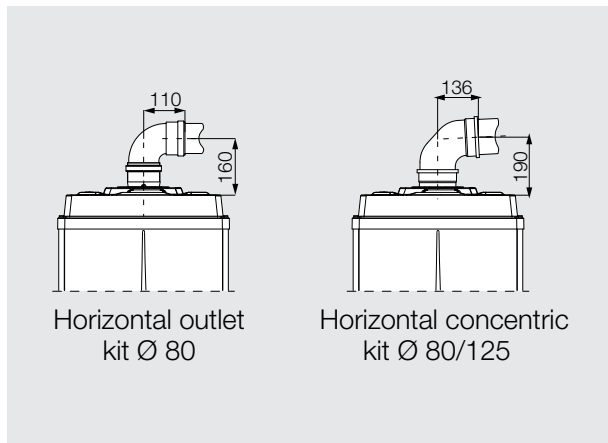

Hydraulic connections

Gas	Heating		Condensate drain
G	R	M	SC
1"	1 1/2"	1 1/2"	25 mm

Flow rate/head graph
VICTRIX PRO 100

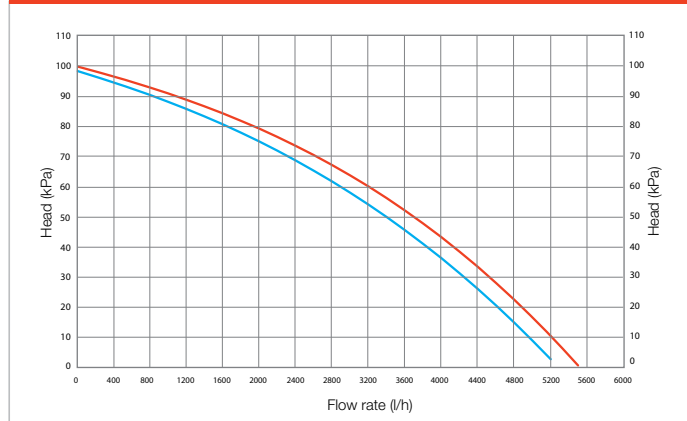

Flow rate/head graph
VICTRIX PRO 120

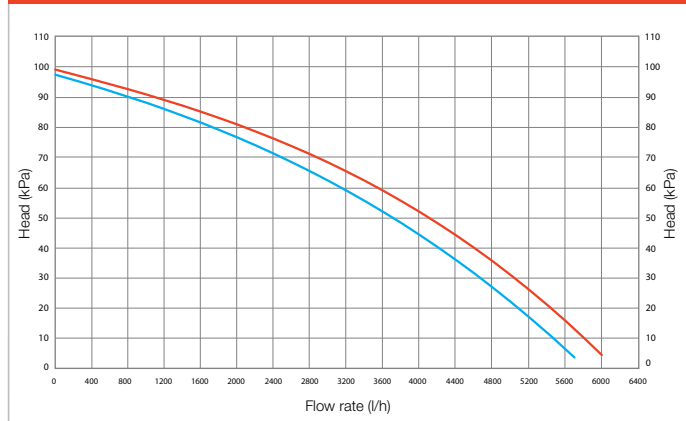





Available head in the system:

— at top speed — at second speed



SYSTEMS OF CONTROL AND HEAT ADJUSTMENT FOR INDIVIDUAL INSTALLATION





Based on the type of installation and comfort required, the following accessories can be used.

Type		Description	Code
Remote control for single VICTRIX PRO		This is a modulating control unit that serves to optimize climatic management of the temperature in rooms. It can only be used on systems with a single temperature control	3.020358
CRONO 7 (weekly digital chronothermostat)		Chronothermostat ON-OFF for control of generator function according to time and temperature settings (comfort and economy)	3.021622
CRONO 7 WIRELESS (wireless weekly digital chronothermostat)		Same functions as CRONO 7 with the advantage of being usable in situations where electric connection of the chronothermostat with wires is impossible	3.021624
External probe		Connected to the boiler board, it optimizes energy consumption by correcting the delivery temperature to the system for smooth temperature operation	3.015266
System delivery probe kit for the boiler (available in June 2014)		Connected to the boiler board, it measures the delivery temperature after the hydraulic manifold	3.024245
Anti freeze protection kit -15 °C		Usable in outdoor installations for minimum temperature as low as -15 °C	3.024513



SYSTEMS OF CONTROL AND HEAT ADJUSTMENT FOR INSTALLATION IN BATTERY





Central heating systems or, in general, modular generators installed in cascade formation, require an adequate system of heat adjustment capable of communicating in a practical, simple way with the boiler so as to satisfy the many and varied needs of the system. For this reason, the following accessories can be used with the VICTRIX PRO installation to control the central heating system and optimize climatic regulation.

Type		Description	Code
Cascade and zone regulator kit		ON-OFF adjustment, modulation and malfunctions of the VICTRIX PRO in cascade (max 8). It can manage any climatic zone regulators in the system (max 3 plus 1 dedicated to the hot tap water circuit)	3.015244
Wall box kit for cascade and zone regulator		If the cascade and zone regulator is not install inside an electrical box	3.015265
Zone manager kit		Electrically connected to cascade and zone regulator, serves to manage climatic conditions of one of system zone, and allow remote control of the cascade and zone regulator	3.015264
Modulating room thermostat		Electrically connected to cascade and zone regulator, serves to manage climatic conditions of one of system zone. Allows control of room temperature only	3.015245
Flow probe		Positioned on the delivery pipe, after the hydraulic separator, it allows the cascade and zone regulator to control system temperature as well as that of any mixed zones	3.015267
Storage tank sensor kit (for managing the storage tank as a zone)		For the storage tank unit managed as a zone (with a circulator) and connected to the cascade regulator (without external 3-way valve). For solar installations managed with cascade and zone regulator two probes are necessary	3.015268
Solar collector temperature probe kit		Positioned on the output of the solar manifolds, this device enables the cascade and zone regulator to control the temperature of the solar fluid	3.019374
External probe		Connected to the cascade and zone regulator, it optimizes energy consumption by correcting the delivery temperature to the system for smooth temperature function	3.024511
Anti freeze protection kit -15 °C		Usable in outdoor installations for minimum temperature as low as -15 °C. One kit for every boiler	3.024513
Tele-management kit		Can be combined exclusively with the cascade and zone regulator for connection to an ethernet network or via router/modem to an ADSL line for connection to a remote system	3.024244







HYDRAULIC OPTIONAL FOR SINGLE INSTALLATION

The following hydraulic accessories are supplied as optionals to complete the individual installation of a VICTRIX PRO.

Type	Description	Code
Safety kit single boiler	 <p>The kit includes thermometer, thermometer holder, lock, thermostat with manual reset, connection tap for pressure gauge, manual reset pressure switch, gas intercepting valve trap, expansion vessel connection and pressure switch for minimum pressure. Insulation as standard</p>	3.023949
Three-way valve kit connection to a separate storage tank	 <p>The kit includes the storage tank probe. The power supply is 230 Vac. Insulation as standard</p>	3.023950
Hydraulic manifold kit for VICTRIX PRO 35-55	 <p>Specially sized for large thermal systems with high water content. Equipped with sludge collection filter on the return pipe. Insulation as standard</p>	3.023951
Hydraulic manifold kit for VICTRIX PRO 80-100-120		3.023952
IPX4D protection box kit for single boiler safety kit		3.024028
By-pass kit for VICTRIX PRO 35-55		3.024677
Condensate neutralizer kit for single installation	 <p>Necessary to neutralize the acidity of the condensation. Inclusive of granulate</p>	3.019857
Granulate for condensate neutralizer		3.019865
“Free standing” support frame kit VICTRIX PRO	 <p>Designed to resolve installation situations in which the wall of the furnace room is not usable. With this modular construction, it is necessary to order a kit for every boiler installed. Approved also for installation outside the building.</p>	3.024246

HYDRAULIC OPTIONAL FOR CASCADE INSTALLATION

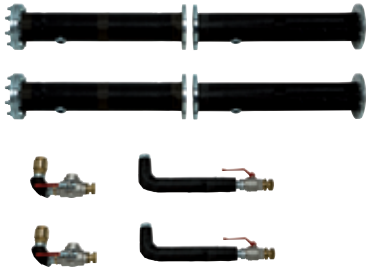
The following hydraulic accessories are supplied as optionals for completion of cascade installations from 2 up to 5 VICTRIX PRO.

Type		Description	Code
Hydraulic manifold kit G 2 1/2" for 2 VICTRIX PRO 35-55 in cascade		Kit for connection of 2 VICTRIX PRO 35-55 in cascade installation; includes a 2-way valves, a 3-way interception valve and a non-return valve for each generator. Insulation as standard	3.023953
Hydraulic manifold kit G 2 1/2" for additional VICTRIX PRO 35-55 in cascade		In combination with kit 3.023953, it serves to connect from 3 to 5 VICTRIX PRO 35-55 boilers in cascade installation (one kit required for each additional boiler); includes a 2-way interception valve, a 3-way interception valve and a non-return valve. Insulation as standard	3.023954
Safety kit G 2" 1/2 for VICTRIX PRO 35-55 in cascade		The kit Includes thermometer, thermometer holder, lock, thermostat with manual reset, connection tap for pressure gauge, manual reset pressure switch, gas intercepting valve trap, expansion vessel connection and pressure switch for minimum pressure. Insulation as standard	3.023955
Hydraulic manifold kit DN100 for 2 VICTRIX PRO 80-100-120 in cascade		Kit to connect 2 VICTRIX PRO 80-100-120 in cascade installation; it includes a 2 way interception valve, a 3-way interception valve and a non-return valve for each generator. Insulation as standard	3.023959
Hydraulic manifold kit DN 100 for additional VICTRIX PRO 80-100-120 in cascade		In combination with kit 3.023959 serves to connect from 3 to 5 VICTRIX PRO 80-100-120 boilers in cascade installation (one kit required for each additional boiler); includes a 2-way interception valve, a 3-way interception valve and a non-return valve. Insulation as standard	3.023960
Safety kit DN 100 for VICTRIX PRO 80-100-120 in cascade		The kit Includes thermometer, thermometer holder, lock, thermostat with manual reset, connection tap for pressure gauge, manual reset pressure switch, gas intercepting valve trap, expansion vessel connection and pressure switch for minimum pressure. Insulation as standard	3.023961
IPX4D protection box kit for cascade safety kit			3.024038



HYDRAULIC OPTIONAL FOR CASCADE INSTALLATION

Type		Description	Code
Condensate neutralizer kit for cascade installation		Necessary to neutralize the acidity of the condensation. Inclusive of granulate	3.019464
Granulate for condensate neutralizer		Extra granulate for condensation passivator kit code. 3.019464 (in case of cascade installation we suggest to buy 2 kits)	3.019865
Hydraulic separator for 100 kW installations		Separator with G2 1/2" threaded connectors. Insulation as standard.	3.020839
Hydraulic separator for 200 kW installations		Separator with G2 1/2" threaded connectors. Insulation as standard.	3.021377
Hydraulic separator for 400 kW installations		Separator with G2 1/2" threaded connectors on boiler side - DN 100 on system side. Insulation as standard.	3.021378
Hydraulic separator for 350 kW installations		Separator with threaded connectors - DN 100. Insulation as standard.	3.023965
Hydraulic separator for 600 kW installations		Separator with threaded connectors - DN 100. Insulation as standard.	3.023962
"Free standing" support frame kit VICTRIX PRO		<p>Designed to resolve installation situations in which the wall of the furnace room is not usable.</p> <p>With this modular construction, it is necessary to order a kit for every boiler installed.</p> <p>Approved also for installation outside the building.</p>	3.024246





“GREEN SERIES” FITTED FLUE SYSTEM

VICTRIX PRO offers a dedicated set of kits for air suction/fume exhaust called “Green Series” by Immergas, with parts and accessories in materials specific for this type of generator.

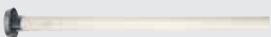

The kits are built to guarantee high resistance to corrosion, ease of installation and functional fit, thanks also to the bayonet fastening system and special sealing gaskets.

VICTRIX PRO boilers are approved type “B₂₃” (with open chamber, fan assisted). There therefore need only a single flue exhaust outlet. If necessary this can be “C” - shaped to function like sealed chamber equipment, fan assisted.

CONFIGURATION B₂₃ - OPEN CHAMBER, FAN ASSISTED

Type		Maximum distance (metres)*				
		VICTRIX PRO 35 1 I	VICTRIX PRO 55 1 I	VICTRIX PRO 80 1 I	VICTRIX PRO 100 1 I	VICTRIX PRO 120 1 I
Terminal vertical outlet kit Ø 80 Code 3.015256		24	30	28	14	8,5
Terminal vertical outlet outdoor kit Ø 80 Code 3.024295		24	30	28	14	8,5
Horizontal kit Ø 80 (to discharge in the chimney) Code 3.015254		24	30	28	14	8,5
Terminal horizontal outlet kit Ø 80 (to discharge horizontally) Code 3.015255		24	30	28	14	8,5

CONFIGURATION C - SEALED CHAMBER, FAN ASSISTED

Type		Maximum distance (metres)*				
		VICTRIX PRO 35 1 I	VICTRIX PRO 55 1 I	VICTRIX PRO 80 1 I	VICTRIX PRO 100 1 I	VICTRIX PRO 120 1 I
Vertical concentric kit Ø 80/125 Code 3.015243		11,5	18	15	11	6
Horizontal concentric kit Ø 80/125 Code 3.015242		8	14,4	11	8	5

* Additional parts of the flue system are available (such as flexible inside pipes Ø 80, 90° angle bends, 45° degree angle bends, etc.) in which case the maximum admissible length decreased by a quantity equal to its “equivalent length”. For more information refer to the documentation supplied with the boiler.



CASCADE INSTALLATION – “GREEN SERIES” EXHAUST MANIFOLDS

With installations in central heating systems, using up to 5 units in the battery, in configuration B₂₃ (open chamber fan assisted), Immergas supplies special exhaust manifolds in PP equipped with flue lock (mechanical shutters), to prevent backflow of combustion products through the other non-functioning boilers. The system is modular: there is an exhaust manifold kit for two boilers and one for additional boilers.

Type	Description	Code	
Exhaust manifold kit 2 VICTRIX PRO 35-55 Ø 160 with flue lock		Serves for exhaust connection of two boilers in cascade	3.024279
Exhaust manifold kit 2 VICTRIX PRO 80-100-120 Ø 200 with flue lock		Serves for exhaust connection of two boilers in cascade	3.024281
Additional exhaust manifold kit VICTRIX PRO 35-55 Ø 160 with flue lock		For connection of an additional boiler (see also page 23)	3.024280
Additional exhaust manifold kit VICTRIX PRO 80-100-120 Ø 200 with flue lock		For connection of an additional boiler (see also page 23)	3.024282
Additional exhaust manifold kit VICTRIX PRO 100-120 Ø 250 with flue lock for 4 VICTRIX PRO 100-120			3.024666
Additional exhaust manifold kit VICTRIX PRO 100-120 Ø 250 with flue lock for 5 VICTRIX PRO 100-120			3.024667
Extension pipe Ø 160 kit 0,5 m long for flue manifold			3.024659
Extension pipe Ø 200 kit 0,5 m long for flue manifold			3.024663
Extension pipe Ø 160 kit 1 m long for flue manifold			3.024516
Extension pipe Ø 200 kit 1 m long for flue manifold			3.024662
Extension pipe Ø 250 kit 1 m long for flue manifold			3.024668
87° bend kit Ø 160 for flue manifold			3.024517
87° bend kit Ø 200 for flue manifold		3.024665	
87° bend kit Ø 250 for flue manifold		3.024670	
No. 2 45° bend kit Ø 160 for flue manifold		3.024518	
No. 2 45° bend kit Ø 200 for flue manifold		3.024664	
No. 2 45° bend kit Ø 250 for flue manifold		3.024669	



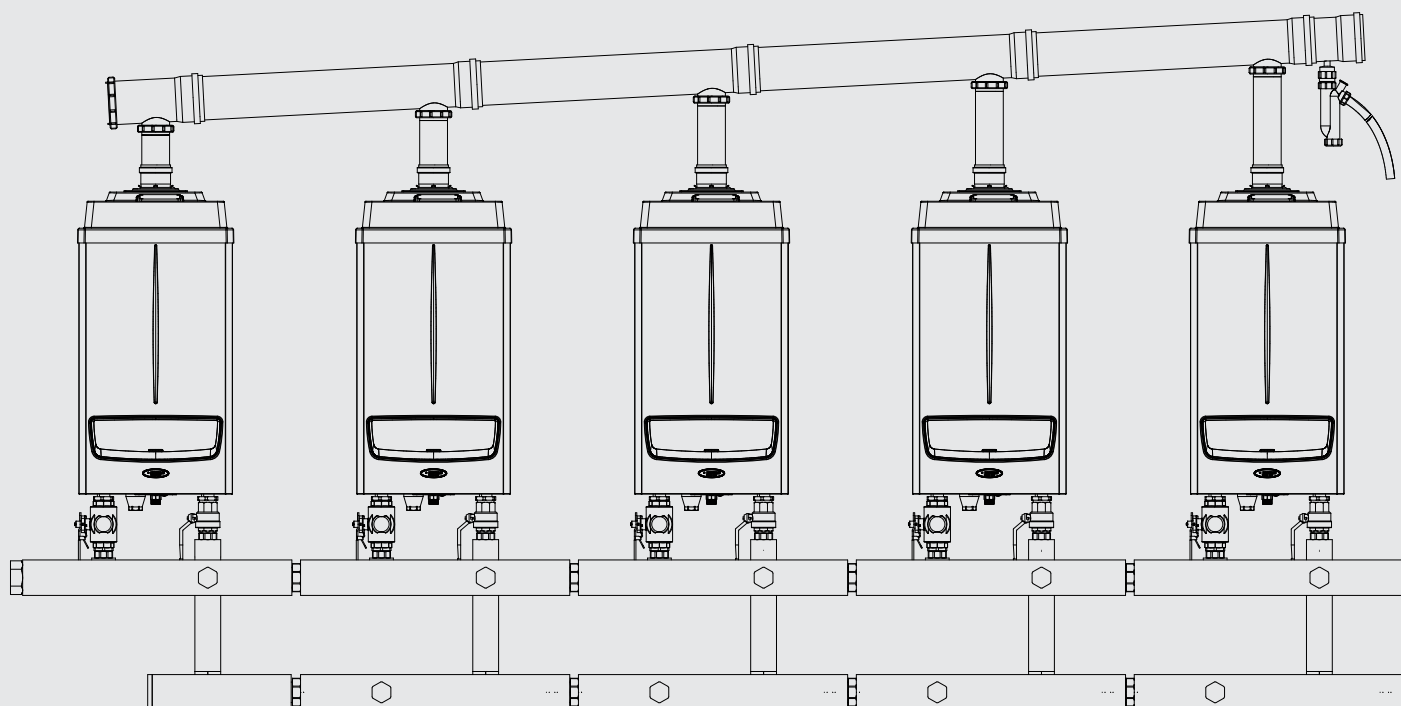

The table below specifies the codes and quantities of exhaust manifold kits necessary, depending on the number of boilers installed in cascade.

Number of boilers	Exhaust manifold kit 2 VICTRIX PRO 35-55 Ø 160 with flue lock Code 3.024279	Additional exhaust manifold kit VICTRIX PRO 35-55 Ø 160 with flue lock Code 3.024280
2 VICTRIX PRO 35-55	1	
3 VICTRIX PRO 35-55	1	1
4 VICTRIX PRO 35-55	1	2
5 VICTRIX PRO 35-55	1	3

Number of boilers	Exhaust manifold kit 2 VICTRIX PRO 80-100-120 Ø 200 with flue lock Code 3.024281	Additional exhaust manifold kit VICTRIX PRO 80-100-120 Ø 200 with flue lock Code 3.024282
2 VICTRIX PRO 80	1	
3 VICTRIX PRO 80	1	1
4 VICTRIX PRO 80	1	2
5 VICTRIX PRO 80	1	3

Number of boilers	Exhaust manifold kit 2 VICTRIX PRO 100-120 Ø 200 with flue lock Code 3.024281	Additional exhaust manifold kit VICTRIX PRO 100-120 Ø 200 with flue lock Code 3.024282	Additional exhaust manifold kit VICTRIX PRO 100-120 Ø 250 with flue lock for 4 VICTRIX PRO 100-120 Code 3.024666	Additional exhaust manifold kit VICTRIX PRO 100-120 Ø 250 with flue lock for 5 VICTRIX PRO 100-120 Code 3.024667
2 VICTRIX PRO 100-120	1			
3 VICTRIX PRO 100-120	1	1		
4 VICTRIX PRO 100-120	1	1	1	
5 VICTRIX PRO 100-120	1	1	1	1

Dimensions and connections

VICTRIX PRO 35-55

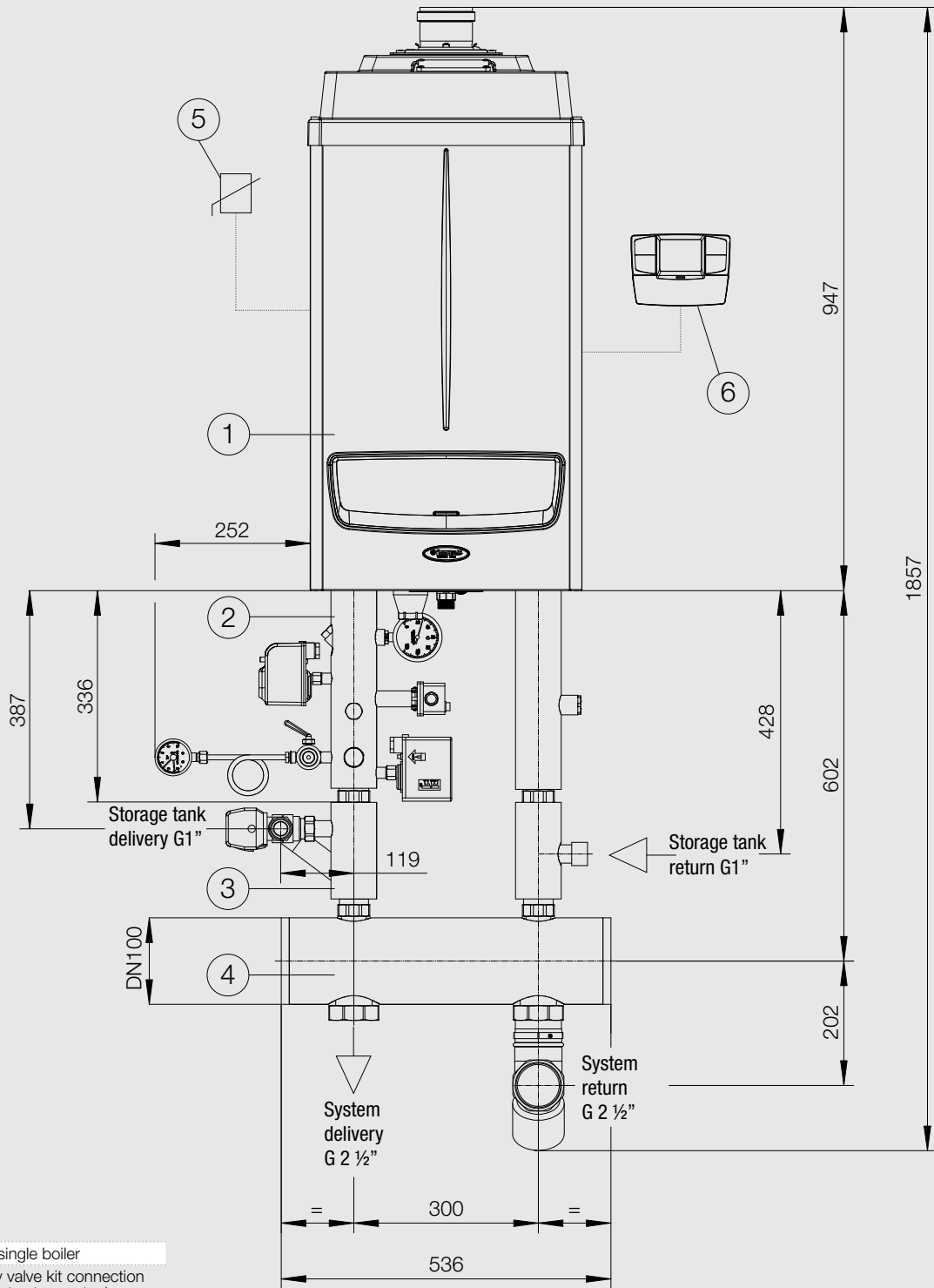

Key

- 1 Boiler
- 2 Safety kit single boiler
- 3 Three-way valve kit connection to a separate storage tank
- 4 Hydraulic separator
- 5 External probe
- 6 CRONO 7



Dimensions and connections

VICTRIX PRO 80-100-120

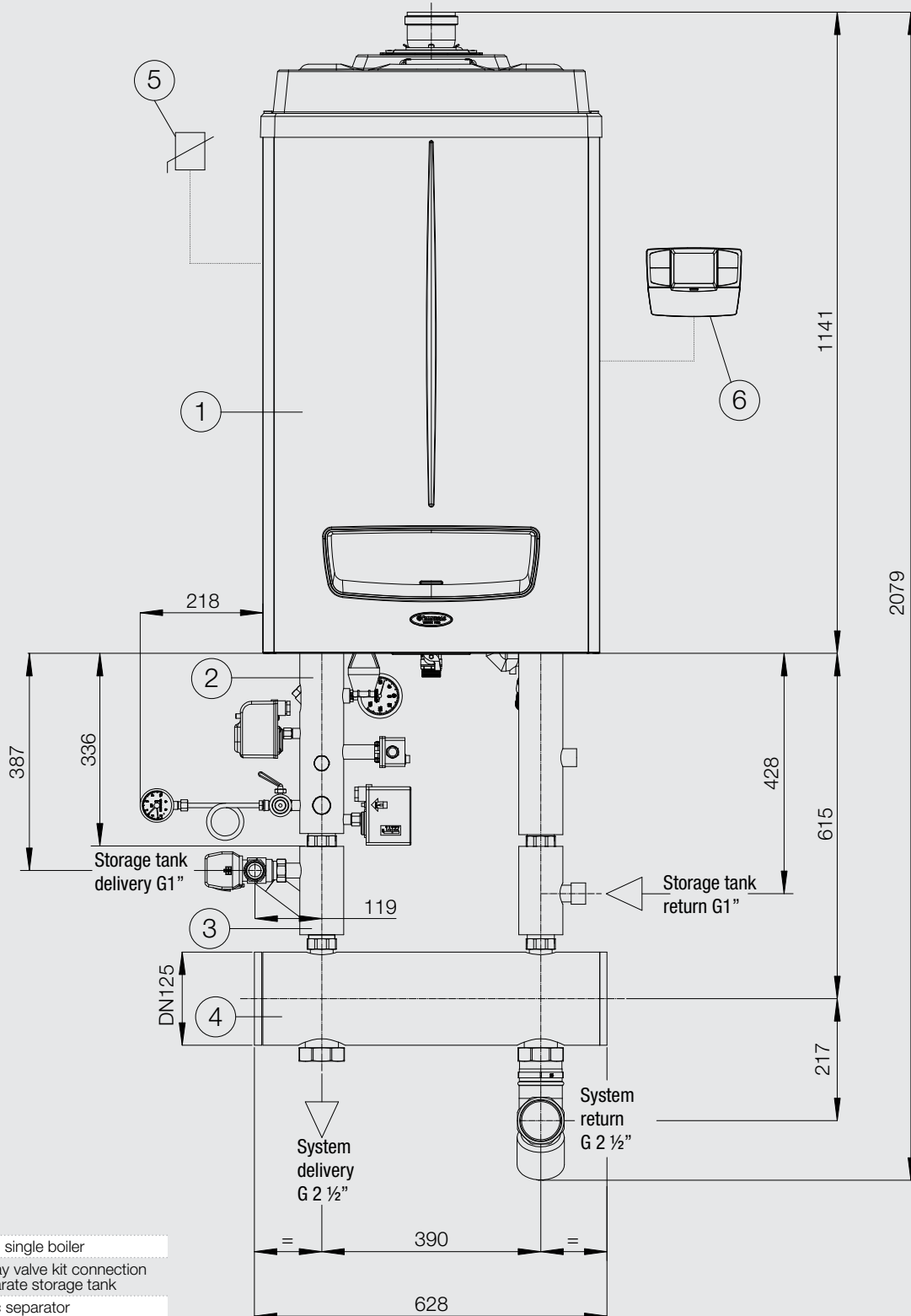

Key

- 1 Boiler
- 2 Safety kit single boiler
- 3 Three-way valve kit connection to a separate storage tank
- 4 Hydraulic separator
- 5 External probe
- 6 CRONO 7



5 VICTRIX PRO 35-55

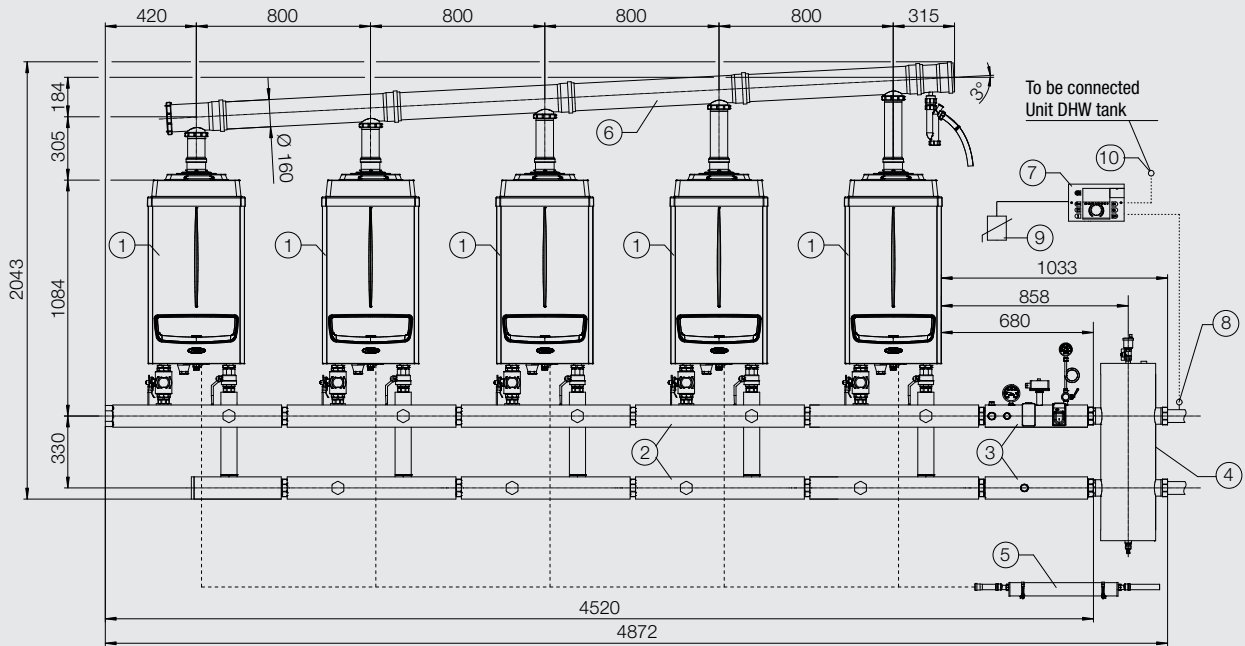

Key

- | | | | |
|--|---|----------------------------------|----------------------------|
| 1 Boiler | 4 Hydraulic separator | 7 Cascade and zone regulator kit | 10 Storage tank sensor kit |
| 2 Hydraulic manifold kit G 2 1/2" | 5 Condensate neutralizer kit for cascade installation | 8 Flow probe | |
| 3 Safety kit G 2 1/2" for boilers in cascade | 6 Exhaust manifold kit | 9 External probe | |

5 VICTRIX PRO 80-100-120

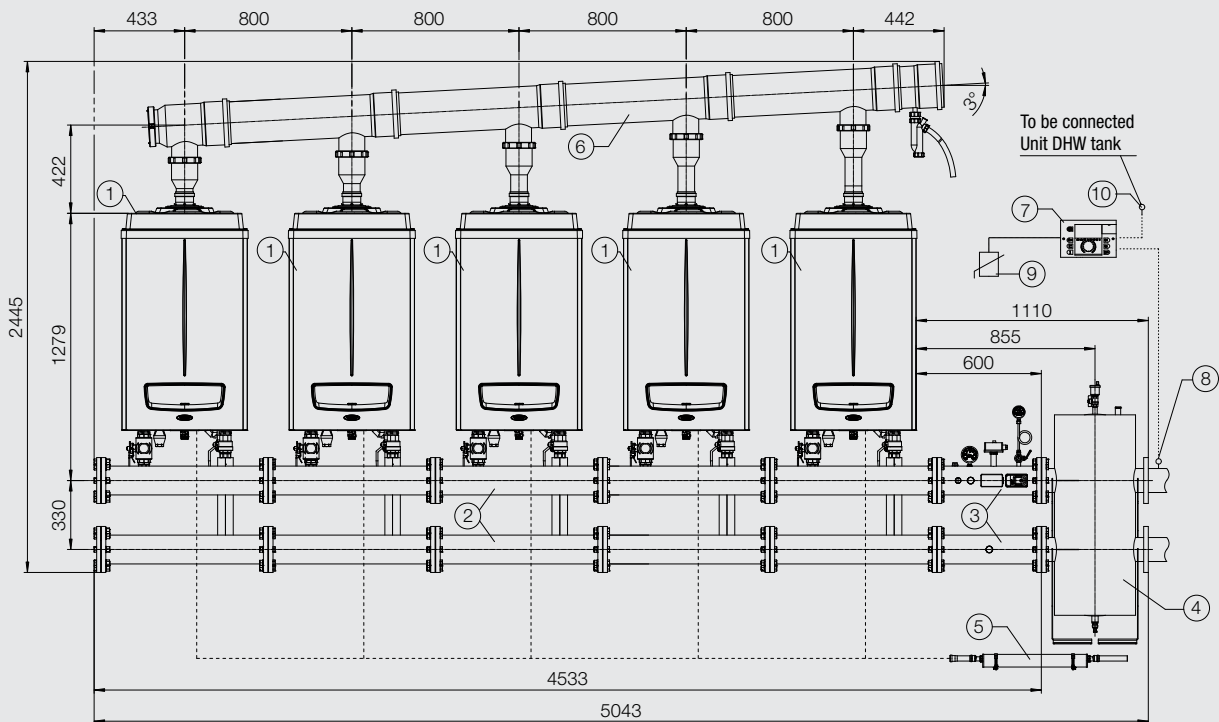

Key

- | | | | |
|--|---|----------------------------------|----------------------------|
| 1 Boiler | 4 Hydraulic separator | 7 Cascade and zone regulator kit | 10 Storage tank sensor kit |
| 2 Hydraulic manifold kit DN 100 | 5 Condensate neutralizer kit for cascade installation | 8 Flow probe | |
| 3 Safety kit DN 100 for boilers in cascade | 6 Exhaust manifold kit | 9 External probe | |

5 VICTRIX PRO 35-55 - "FREE STANDING" SUPPORT FRAME INSTALLATION

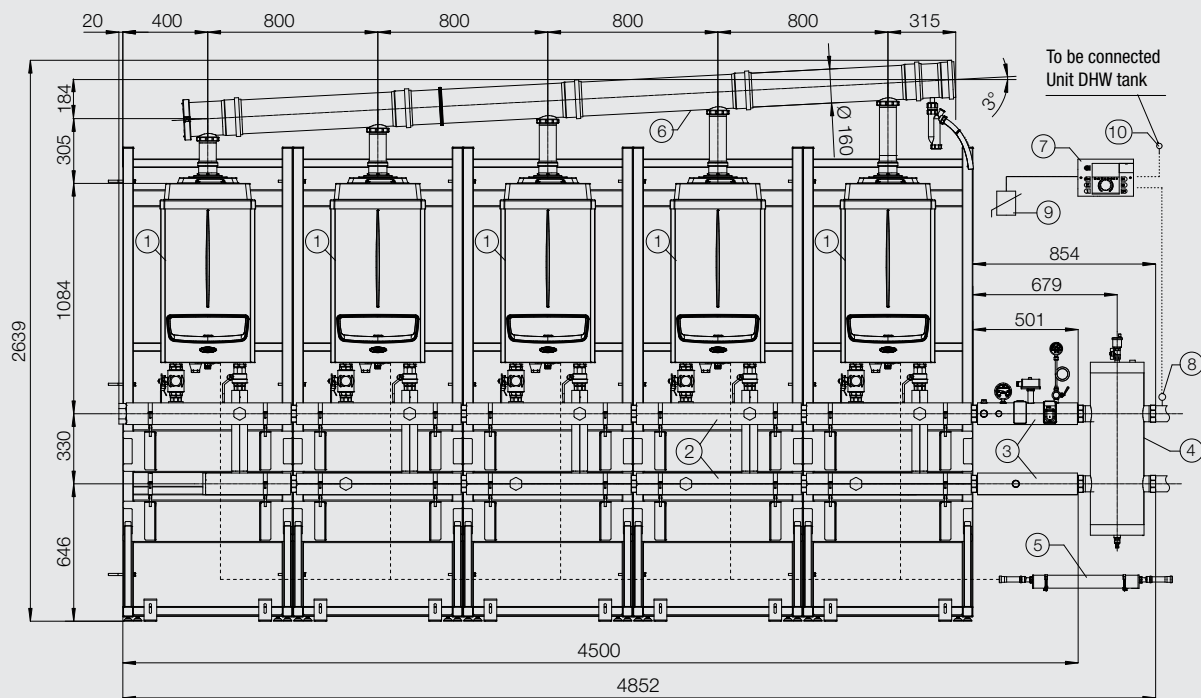

Key

1	Boiler	4	Hydraulic separator	7	Cascade and zone regulator kit	10	Storage tank sensor kit
2	Hydraulic manifold kit G 2 1/2"	5	Condensate neutralizer kit for cascade installation	8	Flow probe		
3	Safety kit G 2 1/2" for boilers in cascade	6	Exhaust manifold kit	9	External probe		

5 VICTRIX PRO 80-100-120 - "FREE STANDING" SUPPORT FRAME INSTALLATION

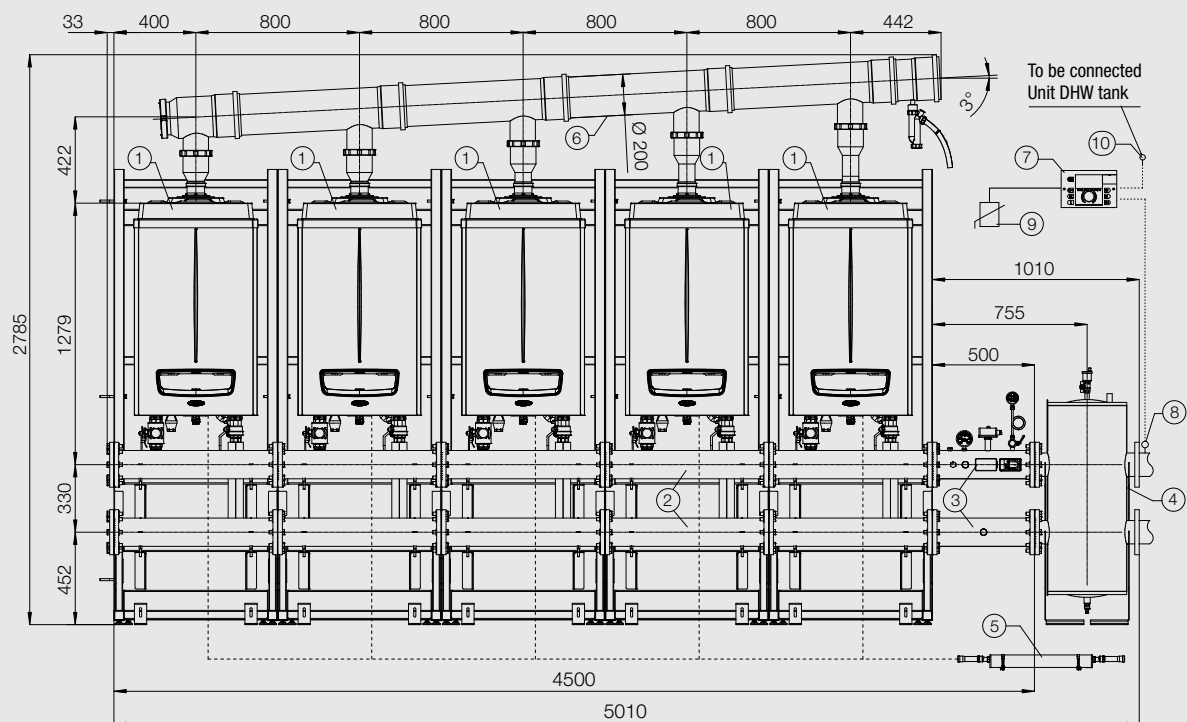

Key

1	Boiler	4	Hydraulic separator	7	Cascade and zone regulator kit	10	Storage tank sensor kit
2	Hydraulic manifold kit DN 100	5	Condensate neutralizer kit for cascade installation	8	Flow probe		
3	Safety kit DN 100 for boilers in cascade	6	Exhaust manifold kit	9	External probe		

Follow us

Immergas Italia



immergas.com

Immergas S.p.A.
42041 Brescello (RE) - Italy
Tel. 0522.689011
Fax 0522.680617



IMMERGAS
SISTEMA DI QUALITÀ
CERTIFICATO
UNI EN ISO 9001:2008

Design, manufacture and post-sale
assistance of gas boilers, gas water heaters
and related accessories