

MANUAL
USER'S

Instruction and **IE**
warning book

 **IMMERGAS**

DEHUMIDIFIER

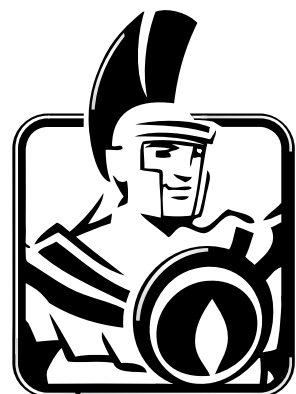

Dear Customer,

Our compliments for having chosen a top-quality Immergas product, able to assure well-being and safety for a long period of time. As an Immergas customer you can also count on a qualified after-sales service, prepared and updated to guarantee constant efficiency of your appliance. Read the following pages carefully: you will be able to draw useful suggestions regarding the correct use of the appliance, the respect of which, will confirm your satisfaction for the Immergas product. For assistance and scheduled maintenance contact Authorised Immergas After-Sales centres: they have original spare parts and are specifically trained directly by the manufacturer.

General recommendations

All Immergas products are protected with suitable transport packaging.

The material must be stored in dry environments protected against bad weather.

The instruction book is an integral and essential part of the product and must be consigned to the new user also in the case of transfer or succession of ownership.

It must be stored with care and consulted carefully, as all of the warnings provide important safety indications for installation, use and maintenance stages.

This instructions manual provides technical information for installing Immergas appliance. As for the other issues related to appliance installation (e.g. safety in the work site, environment protection, injury prevention), it is necessary to comply with the provisions specified in the regulations in force and principles of good practice.

In compliance with legislation in force, the systems must be designed by qualified professionals, within the dimensional limits established by the Law. Installation and maintenance must be performed in compliance with the regulations in force, according to the manufacturer's instructions and by professionally qualified staff, intending staff with specific technical skills in the plant sector, as envisioned by the Law.

Improper installation or assembly of the Immergas appliance and/or components, accessories, kit and devices can cause unexpected problems to people, animals and objects. Read the instructions provided with the product carefully to ensure a proper installation.

Maintenance must be carried out by skilled technical staff. The Immergas Authorised After-sales Service represents a guarantee of qualifications and professionalism.

The appliance must only be destined for the use for which it has been expressly declared. Any other use will be considered improper and therefore potentially dangerous.

If errors occur during installation, operation and maintenance, due to non compliance with technical laws in force, standards or instructions contained in this book (or however supplied by the manufacturer), the manufacturer is excluded from any contractual and extra-contractual liability for any damages and the appliance warranty is invalidated.

For further information regarding legislative and statutory provisions relative to the installation of gas heat generators, consult the Immergas site at the following address: www.immergas.com

For further details on the product CE marking, request a copy of the Declaration of Conformity from the manufacturer, specifying the appliance model and the language of the country.

The manufacturer declines all liability due to printing or transcription errors, reserving the right to make any modifications to its technical and commercial documents without forewarning.

INDEX

1. INTRODUCTION	5
1.1 Preliminary information	5
1.2 Aim and content of the manual	5
1.3 How to store this manual	5
1.4 Manual updates	5
1.5 How to use this manual	5
1.6 Potential risks	6
1.7 General description of symbols used	7
1.8 Safety symbols used	8
1.9 Limitations and prohibited use	8
2. SAFETY	9
2.1 Warning re potentially hazardous toxic substances	9
2.2 Refrigerant handling	9
2.3 Prevention of inhalation of high vapor concentrations	9
2.4 Procedures in the event of accidental release of refrigerant	10
2.5 Main Toxicological information on the type of refrigerant used	10
2.6 First aid measures	10
3. TECHNICAL CHARACTERISTICS	11
3.1 Unit description	11
3.2 Accessories	12
3.3 Unit components	13
3.4 Refrigerant circuit layout	14
3.5 Technical data	15
3.6 Hydraulic circuit pressure drops	15
3.7 Operation limits	16
3.8 Sound data	16
3.9 Safety devices	17
4. INSTALLATION	17
4.1 General safety guidelines and use of symbols	17
4.2 Health and safety Considerations	18
4.3 Personal protective equipment	18
4.4 Inspection	18
4.5 Storage	19
4.6 Unpacking	19
4.7 Lifting and handling	19
4.8 Location and minimum technical clearances	19
4.9 Assembly of the counter and its installation	21
4.10 Installation of dehumidifier into the formwork	22
4.11 Condensate draining connections	22
4.12 Water coil hydraulic connection	22
4.13 How to vent the unit	23
4.14 Ductwork unit connection	23
4.15 Filter extraction	25
4.16 Supply and return grilles installation	25
4.17 Electric connections: preliminary safety information	26
4.18 Electrical data	27
4.19 Electrical connections	27
5. UNIT START UP	29
5.1 Preliminary checks	29
5.2 Wiring diagram	30
5.3 Control panel	30
6. USE	31
6.1 Unit switch on and first start up	31
6.2 Stop	31
6.3 Stand-by	31
6.4 Displaying during an alarm	31
7. MAINTENANCE OF THE UNIT	32
7.1 General warnings	32
7.2 Drive access	32
7.3 Periodical checks	32
7.4 Refrigerant circuit repair	33
8. DECOMMISSIONING	33
8.1 Disconnect the unit	33
8.2 Disposal, recovery and recycling	34
8.3 RAEE Directive (only UE)	34
9. DIAGNOSIS AND TROUBLESHOOTING	34
9.1 Fault finding	34
10. DIMENSIONAL DRAWINGS	35

1. INTRODUCTION

1.1 Preliminary information

Reproduction, storage or transmission of any part of this publication in any form, without the prior written consent of the Company, is prohibited.

The unit to which these instructions refer, is designed to be used for the the purposes described and to be operated in accordance with these instructions.

The Company will not be liable for claims for damage caused to persons, animals, material goods or property caused by improper installation, adjustment and maintenance or improper use. Any use not specified in this manual is prohibited.

This document is intended to provide information only and does not form a contract with third parties.

The Company pursues a policy of constant improvement and development of its products and therefore reserves the right to change the specifications and the documentation at any time, without notice and without obligation to update existing equipment.

1.2 Aim and content of the manual

These instructions are intended to provide the information required for the selection, installation, use and maintenance of the unit.

They have been prepared in accordance with the European Union laws and with the technical standards in force at the date of issue of the instructions.

The instructions contain all the necessary information to prevent any reasonably foreseeable misuse.

1.3 How to store this manual

The manual must be kept in a suitable place with easy access for users and operators, protected from dust and damp.

The manual must always accompany the unit during the entire life cycle of the same and therefore must be transferred to any subsequent user.

1.4 Manual Update

It is recommended that the manual is updated to the latest revision available.

If updates are sent to the customer they must be added to this manual.

The latest information regarding the use of its products is available by contacting the Company.

1.5 How to use this manual



The manual is an integral part of the unit.

Users or operators must consult the manual before performing any operation and especially so when transporting, handling, installing, maintaining, or dismantling the unit in order to eliminate uncertainty and reduce risk.



In these instructions symbols have been used (described in the following paragraphs) to draw the attention of operators and users to the operations that have a higher risk and which must be performed safely.

1.6 Potential Risks

Whilst the unit has been designed to minimize any risk posed to the safety of people who will interact with it, it has not been technically possible to eliminate completely the causes of risk. It is therefore necessary to refer to the requirements and symbolism below:

LOCATION OF RISK	POTENTIAL RISK	METHOD OF INJURY	PRECAUTIONS
Thermal heat exchangers.	Small stab wounds.	Contact	Avoid any contact, use protective gloves.
Fan and fan grilles.	Cuts, eye damage, broken bones.	Insertion of sharp objects through the grid while the fans are operating.	Never put objects through the protection grilles.
Internal component: compressors and discharge pipes	Burns.	Contact	Avoid any contact, use protective gloves.
Internal component: electric cables and metallic parts	Electrocution, severe burns.	Defect in the supply cable insulation, live metallic parts.	Adequate protection of power cables, ensure correct earthing of all metal parts.
External to unit: unit enclosure	Poisoning, severe burns.	Fire due to short circuit or overheating of the supply cable external to unit.	Size cables and mains protection system in accordance with iee regulations.
Low pressure safety valve.	Poisoning, severe burns.	High evaporating pressure causing a refrigerant discharge during maintenance.	Carefully check the evaporating pressure during the maintenance operations.
High pressure safety valve.	Poisoning, severe burns, hearing loss.	Activation of the high pressure safety valve with the refrigerant circuit open.	If possible, do not open the refrigerant circuit valve; carefully check the condensing pressure; use all the personal protective equipment required by law.
Entire unit	External fire	Fire due to natural disasters or combustions of elements nearby unit	Provide the necessary fire-fighting equipment
Entire unit	Explosion, injuries, burns, poisoning, folgoramento for natural disasters or earthquake.	Breakages, failures due to natural disasters or earthquake	Plan the necessary precautions both electrical (suitable differential magneto and electrical protection of the supply lines; greatest care during the connections of the metal parts), and mechanical (special anchors or seismic vibrations to prevent breakages or accidental falls).

1.7 General Description of Symbols Used

Safety symbols combined in accordance with ISO 3864-2:



BANNED

A black symbol inside a red circle with a red diagonal indicates an action that should not be performed.



WARNING

A black graphic symbol added to a yellow triangle with black edges indicates danger.



ACTION REQUIRED

A white symbol inserted in a blue circle indicates an action that must be done to avoid a risk.

Safety symbols combined in accordance with ISO 3864-2:



The graphic symbol "warning" is qualified with additional safety information (text or other symbols).

1.8 Safety symbols used



GENERAL RISK

Observe all signs placed next to the pictogram. The failure to follow directions may create a risk situation that may be injurious to the user.



ELECTRICAL HAZARD

Observe all signs placed next to the pictogram.
The symbol indicates components of the unit and actions described in this manual that could create an electrical hazard.



MOVING PARTS

The symbol indicates those moving parts of the unit that could create risk.



HOT SURFACES

The symbol indicates those components with high surface temperature that could create risks.



SHARP SURFACES

The symbol indicates components or parts that could cause stab wounds.



EARTH CONNECTION

The symbol identifies Earthing connection points in the unit.



READ AND UNDERSTAND THE INSTRUCTIONS

Read and understand the instructions of the machine before any operations.



RECOVER OR RECYCLE MATERIAL



1.9 Limitations and prohibited use

The machine is designed and built exclusively for the uses described in "Limitations of use" of the technical manual. Any other use is prohibited because it may pose a potential risk to the health of operators and users.



The unit is not suitable for operations in environments:

- excessively dusty or potentially explosive atmospheres;
- where there are vibrations;
- where there are electromagnetic fields;
- where there are aggressive atmospheres.

2. SAFETY

2.1 Warning re potentially hazardous toxic substances

2.1.1 Identification of the Type of Refrigerant Fluid Used: R134a:

Tetrafluoroethane (HFC134a) 100% by weight CAS No.: 000811-97-2

2.1.2 Identification of the Type of Oil Used.

The lubricant used is polyester oil. Please refer to the information provided on the compressor data plate.



For further information regarding the characteristics of the refrigerant and oil used, refer to the safety data sheets available from the refrigerant and oil manufacturers.

Main Ecological Information Regarding the Types of refrigerants Fluids used.



ENVIRONMENTAL PROTECTION : Read the ecological information and the following instructions carefully.

2.1.3 Persistence and degradation

The refrigerants used decompose in the lower atmosphere (troposphere) relatively quickly. The decomposed products are highly dispersible and therefore have a very low concentration. They do not influence the photochemical smog which is not among the VOC volatile organic compounds (as stipulated in the guidelines to the UNECE). The constituent refrigerants of R407C (R32, R125 and R134a), do not damage the ozone layer. These substances are regulated under the Montreal Protocol (revised 1992) and regulations EC no. 2037/200 of 29 June 2000.

2.1.4 Effects of discharges

Discharges into the atmosphere of this product does not cause a long-term contamination.

2.1.5 Exposure controls and personal protection

Wear protective clothing and gloves, protect your eyes and face

2.1.6 Professional exposure limits

R134A

HFC-134a TWA 1000 ppm

2.2 Refrigerant handling



Users and maintenance personnel must be adequately informed about the possible risks of handling potentially toxic substances. Failure to follow such instructions can cause damage to personnel or to the unit.

2.3 Prevent inhalation of high vapor concentration

Atmospheric concentrations of refrigerant must be minimized and kept to a level that is below the occupational exposure limit. Vapor is heavier than air and can form dangerous concentrations near the ground where the ventilation rate is lower. Always ensure adequate ventilation. Avoid contact with open flames and hot surfaces as this can cause toxic and irritating decomposition products to form. Avoid contact between liquid refrigerant and the eyes or skin.

2.4 Procedures to be adopted in the event of accidental release of refrigerant

Ensure suitable personal protection (especially respiratory protection) during cleaning operations.

If deemed safe, isolate the source of the leak. If the leakage is small and if adequate ventilation is provided, allow the refrigerant to evaporate. If the loss is substantial ensure that measures are taken to adequately ventilate the area.

Contain spilled material with sand, earth or other suitable absorbent material.

Do not allow the refrigerant to enter drains, sewers or basements, as pockets of vapor can form.

2.5 Main Toxicological Information Regarding the Type of refrigerant used

2.5.1 Inhalation

A high atmospheric concentration can cause anaesthetic effects with possible loss of consciousness. Prolonged exposure may lead to irregular heartbeat and cause sudden death. Higher concentrations may cause asphyxia due to the reduced oxygen content in the atmosphere.

2.5.2 Contact with skin

Splashes of nebulous liquid can produce frostbite. Probably not hazardous if absorbed through the skin. Repeated or prolonged contact may remove the skin's natural oils, with consequent dryness, cracking and dermatitis.

2.5.3 Contact with eyes

Splashes of liquid may cause frostbite.

2.5.4 Ingestion

While highly improbable, may produce frostbite.

2.6 First Aid Measures



Adhere scrupulously to the warnings and first aid procedures indicated below.

2.6.1 Inhalation

Move the person away from the source of exposure, keep him/her warm and let him/her rest. Administer oxygen if necessary. Attempt artificial respiration if breathing has stopped or shows signs of stopping. If the heart stops, perform external heart massage. Seek medical assistance.

2.6.2 Contact with skin

In case of contact with skin, wash immediately with lukewarm water. Thaw tissue using water. Remove contaminated clothing. Clothing may stick to the skin in case of frostbite. If irritation, swelling or blisters appear, seek medical assistance.

2.6.3 Contact with eyes

Rinse immediately using an eyewash or clean water, keeping eyelids open, for at least ten minutes. Seek medical assistance.

2.6.4 Ingestion

Do not induce vomiting. If the injured person is conscious, rinse his/her mouth with water and make him/her drink 200-300ml of water. Seek immediate medical assistance.

2.6.5 Further medical treatment

Treat symptoms and carry out support therapy as indicated. Do not administer adrenaline or similar sympathomimetic drugs following exposure, due to the risk of cardiac arrhythmia.

3. TECHNICAL CHARACTERISTICS

3.1 Unit description

The dehumidifiers are built vertically, equipped with robust galvanised steel frame, properly designed to operate in combination with radiant cooling systems. The units have been designed both to ensure the dehumidification of the air under conditions of air thermally neutral, ie at the same temperature at which they levy it, both in conditions of cooled air, managing very small air flow thus avoiding uncomfortable drafts typical of traditional air conditioning. The units, can operate even without pre and post cooling coils, this option could be very useful in middle seasons when it is necessary to dry but the air conditioning system is not in operation.

All units are fully in compliance with the European norms and provided with CE marks and dedicated conformity certificate.

3.1.1 Frame

All units are made from hot-galvanised thick sheet metal, to ensure the best resistance against the corrosions. The cabinet frame is made by removable panels to allow an easy inspection and internal maintenance. The condensing drip tray is supply as standrad in all models and it is made in plastic material.

3.1.2 Refrigerant Circuit

The refrigerant circuit is made by using international primary brands components and according to ISO 97/23 concerning welding procedures. The refrigerant gas used in these units is R134a. The refrigerant circuit includes: filter drier, capillary expansion device, Schrader valves for maintenance and control, pressure safety device (according to PED regulation).

3.1.3 Compressor

The compressor is reciprocating type, equipped with crankcase heater and thermal overload protection by a klixon embedded in the motor winding. It's mounted on rubber vibration dampers and, by request, it can be supplied with some jackets to reduce the noise (accessory).

3.1.4 Condensers and Evaporators

The condensers and evaporators are made of copper pipes and aluminium fins. The diameter of the copper pipes is 3/8" and the thickness of the aluminium fins is 0,1 mm. The tubes are mechanically expanded into the aluminium fins to improve the heat exchange factor. The geometry of these condensers guarantees a low air side pressure drop and then the use of low rotation (and low noise emission) fans. All the units have a stainless steel drip tray and use a third brazed plate heat exchanger made of stainless steel AISI 316 as condenser in cooling mode.

3.1.5 Pre and post cold water coils

The pre and post cold water coils are made of copper pipes and aluminium fins. The diameter of the copper pipes is 3/8" and the thickness of the aluminium fins is 0,1 mm. The tubes are mechanically expanded into the aluminium fins to improve the heat exchange factor. The pre-cooling coil is used to increase the dehumidification capacity of the unit, while the post-cooling coil is used to keep the outlet air temperature at the same inlet value.

3.1.6 Water condenser

Type-brazed plate, made of stainless steel AISI 316; The water condenser is used as cooling integration.

3.1.7 Supply fan

The supply fan is centrifugal type, double inlet with forwards blades, dynamically and statically balanced and directly connected to a 3 speed fan motor. Installed into the unit by interposed ant-vibration kit.

3.1.8 Air Filter

It's supplied standard with the unit and it's built in nylon. It can be removed for differential disposal, class G2, according to EN 779:2002.

3.1.9 Microprocessor

All units are equipped with a microprocessor for controlling the timing of the compressor, defrosting cycles and alarms. A special card with light signals indicates the presence of the supply voltage, the activation of defrosting cycle or the presence of an alarm.

3.1.10 Electric box

The electric switch board is made according to electromagnetic compatibility norms CEE 73/23 and 89/336. The accessibility to the board is possible after removing the front panel of the unit. Ready for the connection to the power and to the consensus control, The terminal board is also supplied with voltage free contacts for remote ON-OFF. The terminal block is also arranged with two (2) free contacts to allow operation in ventilation mode only (the 1st) in cooling mode operation the 2nd. Closing the first contact, it will be enabled for operation in fan only while the dehumidification function will be disabled.

3.1.11 Control and protection devices

All units are supplied with the following control and protection devices:

Water temperature sensor, that signals to the microprocessor the eventual overcome of the hot water temperature set point in the pre and post water coils during winter operation. In this condition the compressor is disconnected while the fan always run and, when the water temperature returns within the operation limits, restarts the compressor. The water sensor stops the compressor when the water temperature is above 35°C.

3.1.12 Test

All the units are fully assembled and wired at the factory, carefully evacuated and dried after leak tests under pressure and then charged with ecologic refrigerant. They are all fully operational tested before shipment. They all conform to European Directives and are individually marked with the CE label and provided with Conformity Declaration.

3.2 Accessories

3.2.1 Casing

In galvanized sheet allows the recess of the unit inside niche. The casing is provided with appropriate tabs for a secure fastening to the wall and arranged adequate openings for wiring and plumbing. The casing is provided with a neck part and assembly kit.

3.2.2 Supply and Return Grilles

In white lacquered wood, prepared for the inlet and outlet air temperature. The grille is installed on the dehumidifier deck using special fixing bolts supplied along with grille. The grille is provided with dedicated neck.

3.3 Unit components

Frontal view

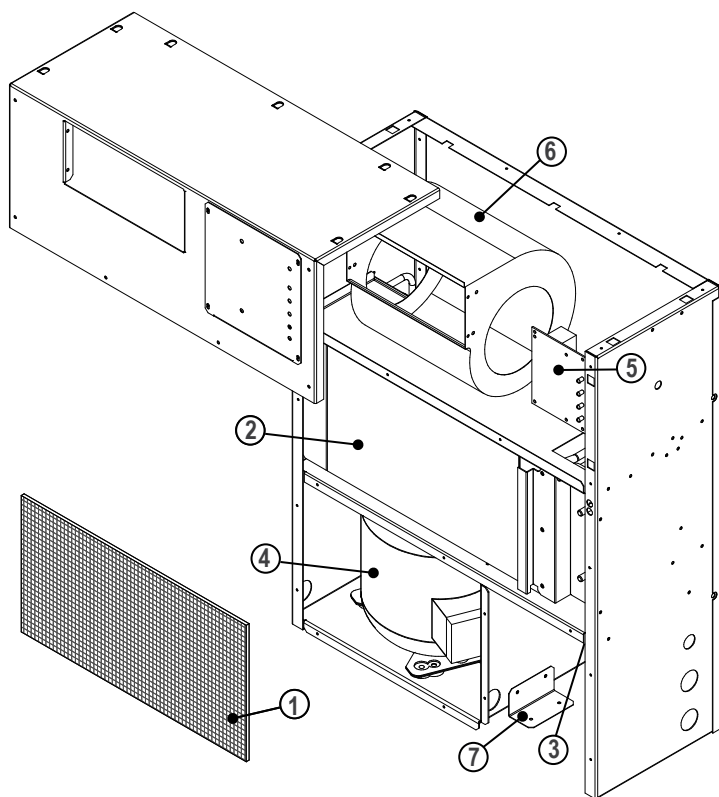

Back view

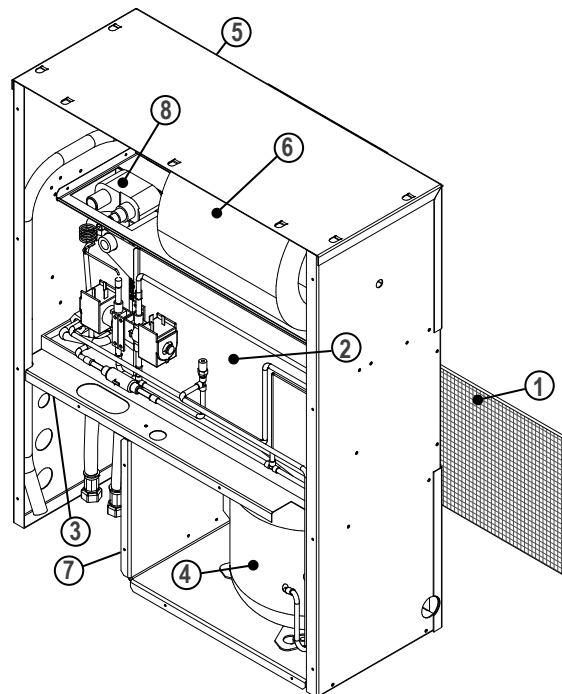

1	Air filter	5	Electronic card
2	Pre-cooling coil	6	Fan
3	Condensing drain	7	Bracket
4	Compressor	8	Condenser water

3.4 Refrigerant circuit layout

The operation of the dehumidifier is as follows: the fan takes the air from the ambient (7) and it's made go through the filter (1) and the pre-cooling water coil (2) where it's cooled and brought to a condition closed to saturation. Now it passes through the evaporating coil (3) where it's further cooled and dehumidified. At this point there are two possible modalities:

- Modality with neutrum air: The air passes now through the condensing coil (5) which allows to condensate the 50% of the total gas, (the unit condensate the 50% on air with the heat exchanger (5) and the 50% in water with the heat exchanger (10)) then there is the postheating so that to avoid to send air in the ambient in neutrum thermic conditions.
- Modality with cooled air: The unit condensates the 100% in water through the heat –exchanger (10). The air, then, go through the condenser (5) (disabled) where does not change its characteristics (temperature and humidity).

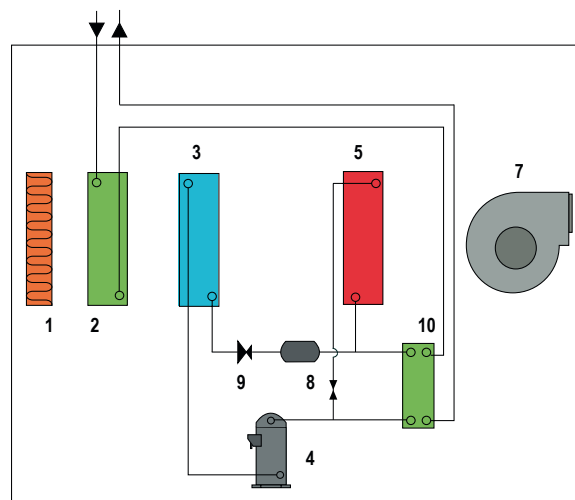

Dehumidifier can work with air dehumidification mode with cold air only if feed by the water plant (normally around 15 ÷ 18°C). In the absence of cold water, the unit must be switched manually in winter mode, to operate in dehumidification + heating.

3.5 Technical data

Refrigerant		R134a
Refrigerant charge	Kg	0,62
Global warming potential (GWP)		1430
Equivalent CO₂ charge	t	0,89
Dehumidification capacity ⁽¹⁾	l/24h	20,1
Power supply	V/Ph/Hz	230/1/50
Cooling capacity ⁽¹⁾	W	1250
Nominal input power ⁽¹⁾	W	340
Nominal input current ⁽¹⁾	A	2,5
Maximum input power ⁽⁴⁾	W	450
Maximum input current ⁽⁴⁾	A	2,8
Pre+Post nominal water flow	l/h	---
Pressure drops	kPa	---
Pre+Condenser nominal water flow	l/h	150
Pressure drops	kPa	7,8
Air Flow	m ³ /h	250
Available static pressure (max speed)	Pa	43
Sound power level ⁽²⁾	dB(A)	45
Sound pressure level ⁽³⁾	dB(A)	37

Performances refer to the following conditions:

(1) Room Temperature 26 °C relative humidity 65%, with cold water coil water inlet temperature 15°C.

(2) Sound power level measured in accordance to ISO 9614.

(3) Sound pressure level measured at 1 mt from the unit in free field conditions direction factor Q=2 according to ISO 9614, minimum fan speed.

(4) Room Temperature 35°C relative humidity 80%.

3.6 Hydraulic circuit pressure drops

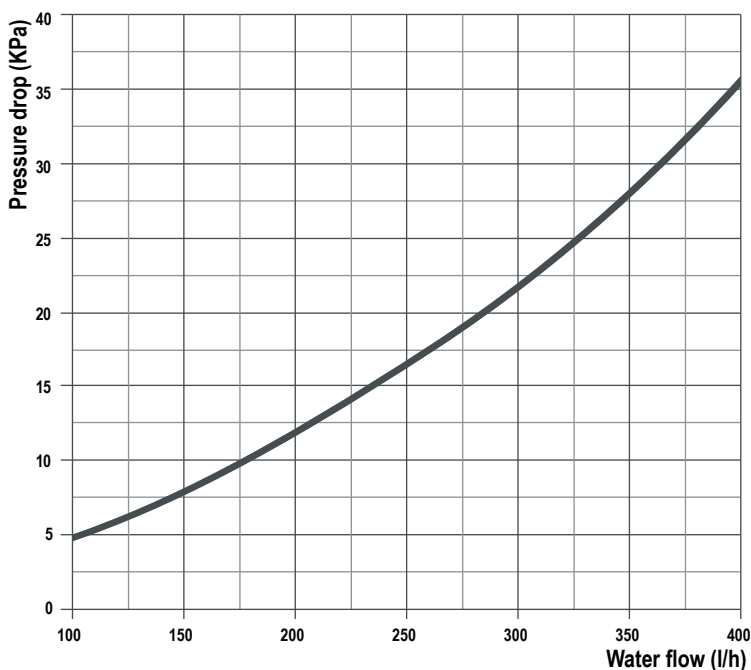

3.7 Operation limits

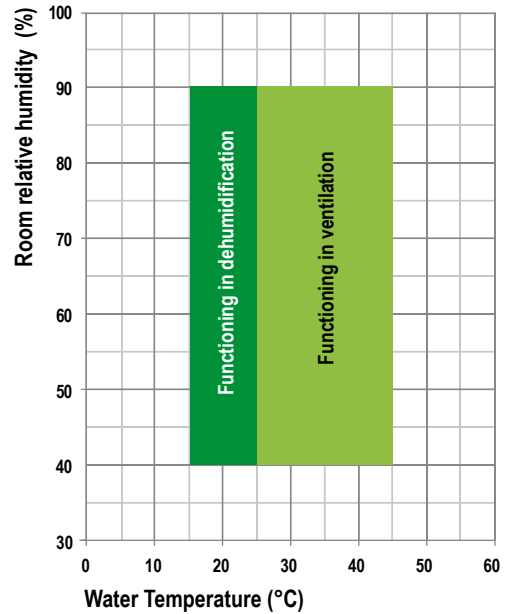
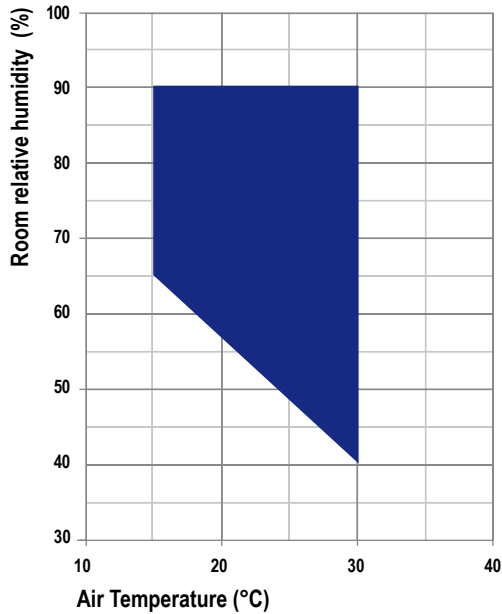

The units **MUST** be used within the operation limit indicated in the diagrams. The warranty will be invalidated if the units are used in ambient conditions outside the limits reported. If there is the necessity to operate in different conditions, please contact our technical office.



The units are designed and manufactured to work with ambient temperatures from 15 ° C to 30 ° C and relative humidity from 40% to 90%. The temperature of the supply water can vary from 15 ° C to 45 ° C. When the water temperature exceeds 25 ° C the unit will work only in ventilation mode.



The units are designed to operate within false ceiling and/or heated technical room. The units are **NOT** suitable for outdoor installations and / or technical room w/o heat (attics, rooms communicating with the outside) as it may form condensation on the walls and inside the unit cabinet causing damages.

3.8 Sound Data

Sound Data											
Octave band (Hz)								Lw		Lp	
63	125	250	500	1K	2K	4K	8K	dB	dB(A)	dB(A)	
dB	dB	dB	dB	dB	dB	dB	dB	dB	dB(A)	dB(A)	
56,1	47,3	41,2	39,7	38,6	33,2	29,8	20,7	56,9	43	35	

Lw: Sound power level according to UNI EN ISO 3746:1997.

Lp: Sound pressure level measured at 1 mt from the unit in free field conditions direction factor Q=2 according to ISO 9614, minimum fan speed.

3.9 Safety devices

3.9.1 High pressure switch

The high pressure switch stops the unit when the condensing pressure is higher than the set value. The restart is manual (you need to press the button on the pressure switch) and it can be carried out only when the pressure is under the value indicated by the differential set.

3.9.2 Defrost thermostat

It's a device which signals to the electronic control, the necessity to make the defrost cycle. Once the defrost cycle is activated, the defrost thermostat determines also its conclusion.

3.9.3 Safety thermostat

It's a device which signals to the electronic control that the limits have been exceeded (pre-post coil inlet water temperature). In this situation the compressor is disabled while the fan keeps on working. When the standard conditions are reset, the compressor starts its working again. This function is active only in winter.

3.9.4 Defrost

The frost on the coil, obstructs the air flow, reduces the available exchange area, consequently the unit performances and can seriously damage the system. All the units are supplied, standard, with a control which defrost automatically the heat exchanger if necessary. This control provides a temperature probe (defrost thermostat) on the unit evaporator. When the defrost cycle is required, the microprocessor control (according to set parameters) starts working (the yellow led turns on) according to these modalities:

- air defrost: the compressor is switched off while the fan keeps on working.

For both modalities, at the end of the defrost cycle, there is the dripping time.

For the model GH50-50W, the defrost is cyclical (the microprocessor makes the defrost cycle every 30 minutes), for the GH100-200, both air cooled and water cooled, the defrost cycle is made in relation to the defrost panel.

4. INSTALLATION

4.1 General safety guidelines and use of symbols



Before undertaking any task the operator must be fully trained in the operation of the machines to be used and their controls. They must also have read and be fully conversant with all operating instructions.



All maintenance must be performed by TRAINED personnel and be in accordance with all national and local regulations.



The installation and maintenance of the unit must comply with the local regulations in force at the time of the installation.



Avoid contact and do not insert any objects into moving parts.

4.2. Health and safety Considerations



The workplace must be kept clean, tidy and free from objects that may prevent free movement. Appropriate lighting of the work place shall be provided to allow the operator to perform the required operations safely. Poor or too strong lighting can cause risks.



Ensure that work places are always adequately ventilated and that respirators are working, in good condition and comply fully with the requirements of the current regulations.

4.3 Personal protective equipment



When operating and maintaining the unit, use the following personal protective equipment listed below, required by law.



Protective footwear.



Eye protection.



Protective gloves.



Respiratory protection.



Hearing protection.

4.4 Inspection

When installing or servicing the unit, it is necessary to strictly follow the rules reported on this manual, to conform to all the specifications of the labels on the unit, and to take any possible precautions of the case. Not observing the rules reported on this manual can create dangerous situations. After receiving the unit, immediately check its integrity. The unit left the factory in perfect conditions; any eventual damage must be questioned to the carrier and recorded on the Delivery Note before it is signed. The company must be informed, within 8 days, of the extent of the damage. The Customer should prepare a written statement of any severe damage.

Before accepting the unit check:

- The unit did not suffer any damage during transport;
- The delivered goods are conforming to what shown in the delivery note.

In Case of Damage

- List the damage on the delivery note
- Inform the Company of the extent of the damage within 8 days of receipt of the goods. After this time any claim will not be considered.
- A full written report is required for cases of severe damage.

4.5 Storage

Units should be stored under cover and ideally, should remain in their packaging. The tools that are supplied for opening the electrics box should be formally transferred to the person responsible for the plant.

4.6 Unpacking



Packaging could be dangerous for the operators.

It is advisable to leave packaged units during handling and remove it before the installation. The packaging must be removed carefully to prevent any possible damage to the machine. The materials constituting the packaging may be different in nature (wood, cardboard, nylon, etc.).



The packaging materials should be separated and sent for disposal or possible recycling to specialist waste companies.

4.7 Lifting and handling

When unloading the unit, it is strongly recommended that sudden movements are avoided in order to protect the refrigerant circuit, copper tubes or any other unit component. Units can be lifted by using a forklift or, alternatively, using belts. Take care that the method of lifting does not damage the side panels or the cover. It is important to keep the unit horizontal at all time to avoid damage to the internal components.

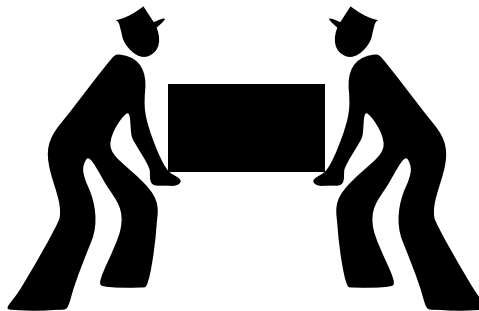

4.8 Location and minimum technical clearances



The unit has to be installed such that maintenance and repair is possible. The warranty does not cover costs for the provision of lifting apparatus, platforms or other lifting systems required to perform repairs during warranty period.



The installation site should be chosen in accordance with EN 378-1 and 378-3 standards. When choosing the installation site, all risks caused by accidental refrigerant leakage should be taken into consideration.

In the next drawing, the typical ceiling installation is shown (typical for residential buildings, offices etc.) where the unit is hanging thanks to the help of 4 brackets supplied standard. The brackets must be connected to the vibration dampers which have to be chosen according to the kind of structure they will be fixed to. It's advisable to cover the inside of the false ceiling with high density bitume layer and to foresee one or more openings to have the possibility to clean the air filters, to control the refrigerant circuit and to check the electrical board.



The casing front profile must be flush with the finished plaster wall.



Once the casing is fixed to the wall, the machine can be finally fitted. The unit is fixed to the casing using the dedicated screws supplied.

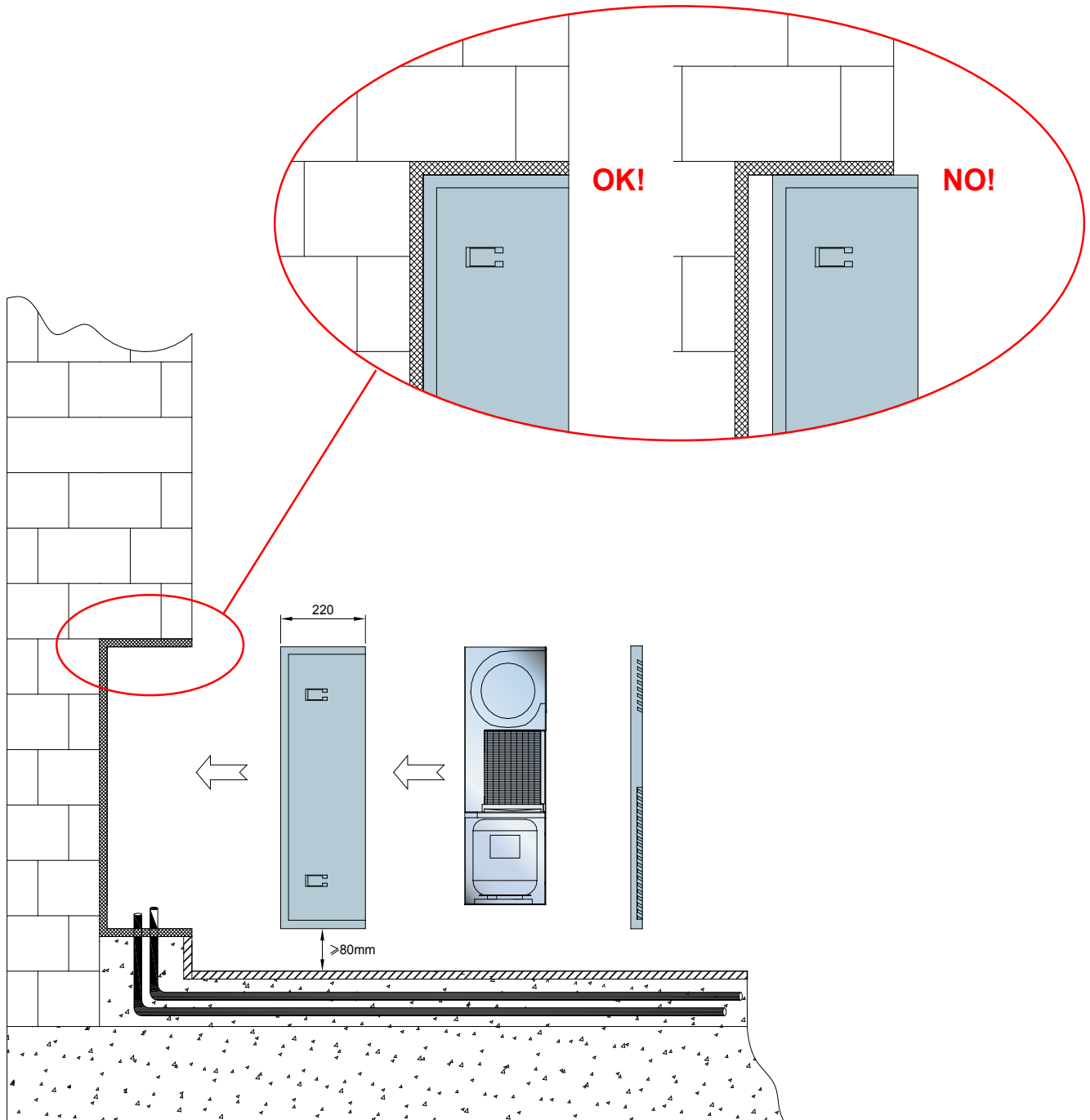

4.9 Assembly of the counter and its installation

The dehumidifier needs for its proper installation, a casing made of galvanized steel recessed in the wall. The housing will always be supplied separately and removed. For his installation, proceed to the assembly by following the instructions in this drawing, using the provided screws.

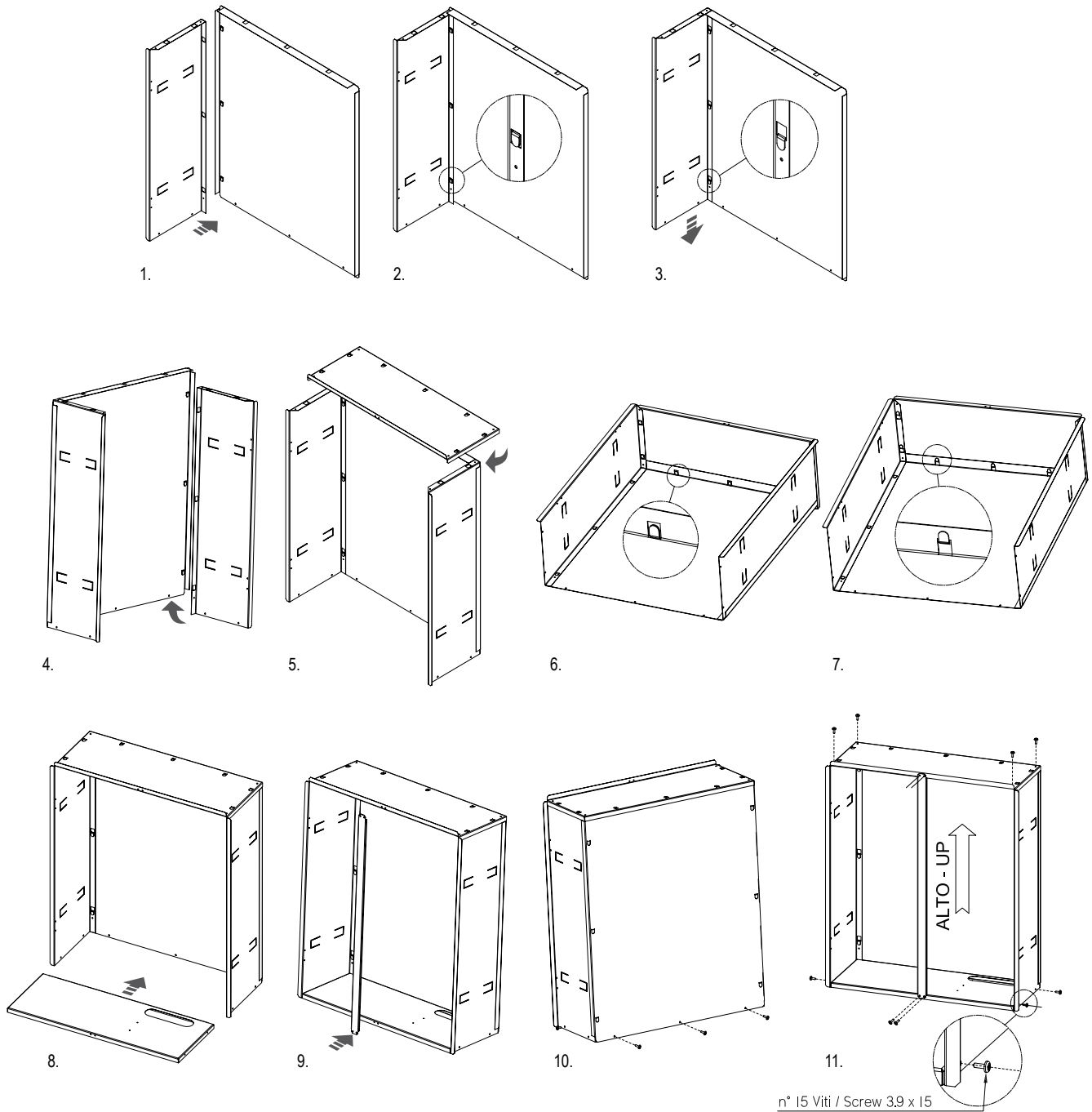

Before fitting the formwork into the dedicated niche , pre-slice kit must be open to facilitate its fastening (see photograph below).

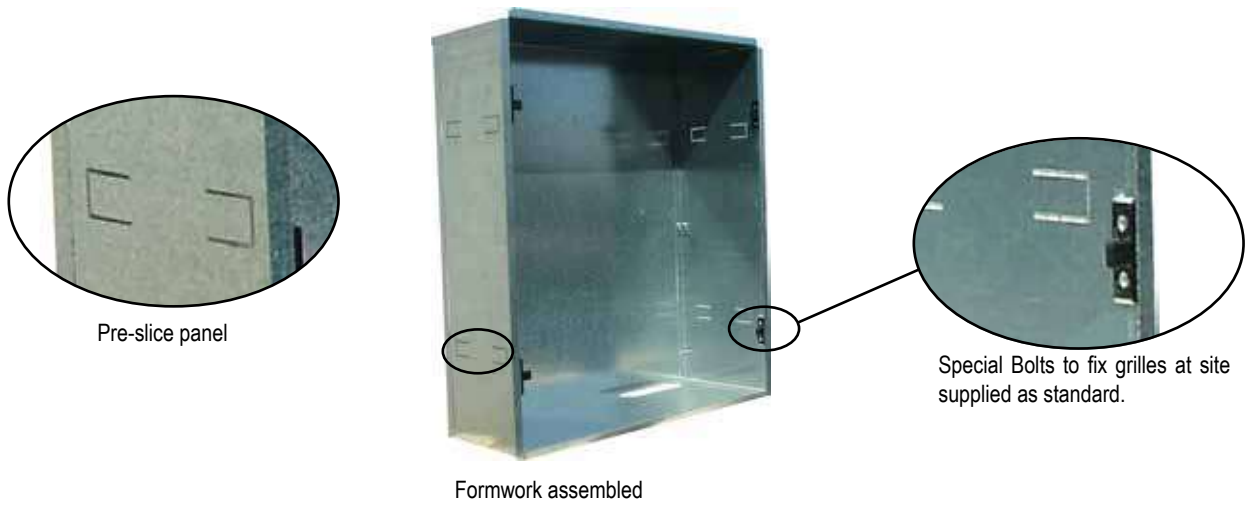

4.10 Installation of dehumidifier into the formwork

The dehumidifier will be inserted in the formwork, possibly cutting the pre-slice placed in correspondence of the connections, in order to facilitate insertion. The final attachment to the formwork will be carried out on the right and left sides with screws, using the holes provided.

4.11 Condensate draining connections

Condensate draining on dehumidifiers should be done with a rubber pipe passing fixed to a pipe fitting with an external diameter of 20 mm located on the lateral panel. On the condensate discharge pipe it must be installed a syphon with a minimum height equal to the suction pressure of the fan.

4.12 Water coil hydraulic connection

The dehumidifier is connected to the cooled water plant to grant the inlet in ambient of air in neutral conditions. On the units GH-GHW the connection is done using the female gas attacks 1/2" always present on the unit.





For a correct functioning of the unit, it's advisable to bleed carefully the circuit using the vent valve present in the unit.



The inlet maximum water temperature allowed is 45°C.
The inlet maximum water temperature allowed is 15°C.

4.13 How to vent the unit

For a correct operation of the system it is mandatory to remove the air from the hydraulic circuit. To do that Hidros recommend to use the proper vent valve positioned in front of the unit (see picture).

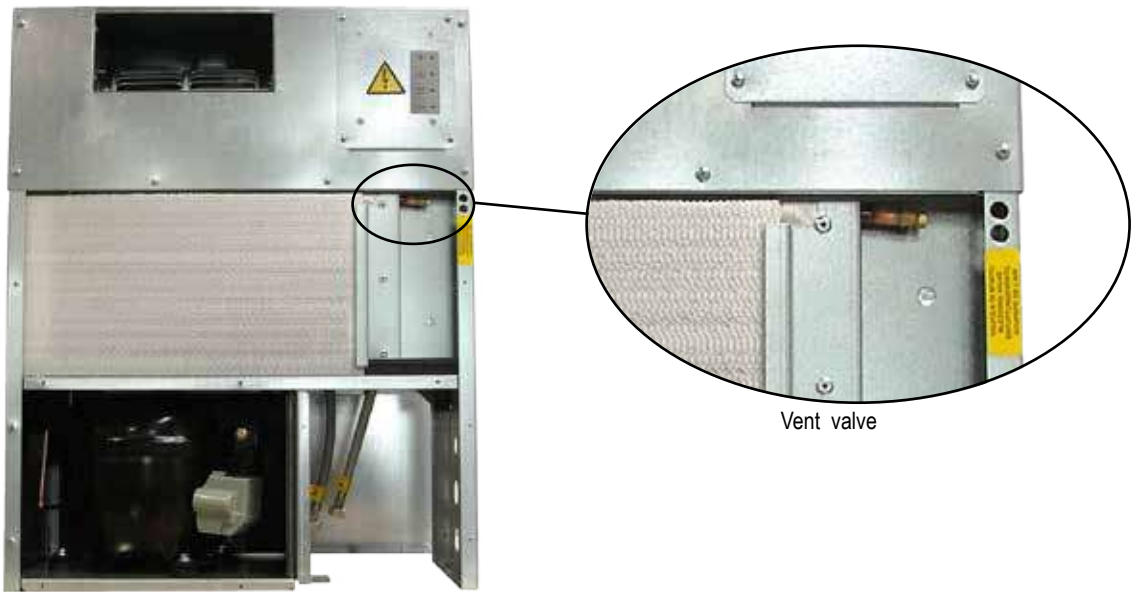

4.14 Ductwork unit connection

All units are fitted with ductable centrifugal fans. In particular conditions, the air flow can be ducted. In this case the supply fan can be turned 90° (see drawing), thus allowing the channeling of unit.

In the case of channels a flanged connection with larger air eject hole must be used (refer to the dimensional drawing of unit).

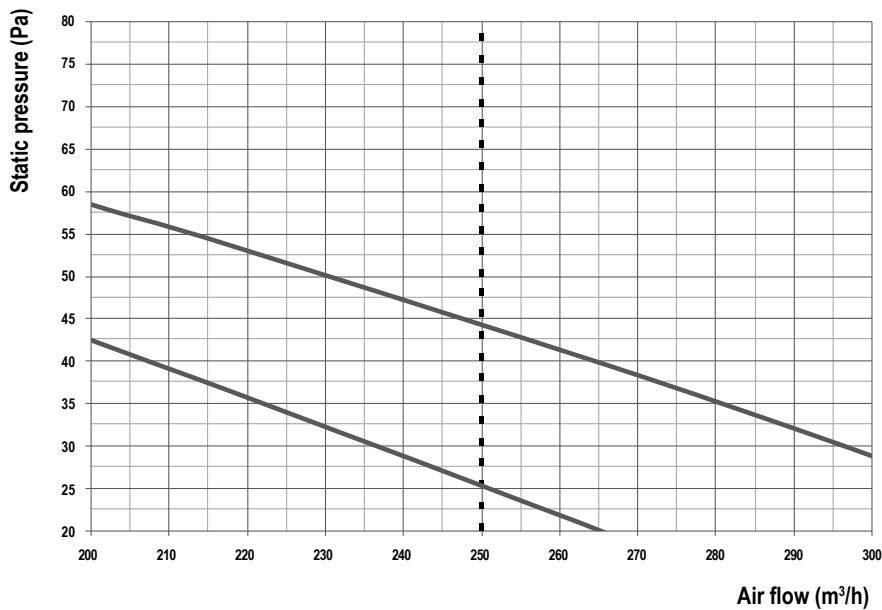



To allow the correct functioning of the dehumidifiers, it's important to grant a constant air flow to the unit. This flow must be close to the nominal value (see the drawing). The maximum tolerance allowed is 20%. .
The installer will take care to verify, during the start-up, the air flow to the unit and modify, if necessary, the speed of the fans.



If the air speed through the evaporating coil exceed the $1,5\div 2$ m/s, the dehumidification capacity of the unit is strongly reduced and the required environmental conditions can be compromised.



Speed wired in factory.

4.15 Filter extraction

The filter extraction of a dehumidifier is made unscrewing the two screws which fix it to the frame, as shown in the following images,



4.16 Supply and return grilles installation

After the assembly and installation of the formwork, inside which it is secured the unit, must be fitted to the formwork itself the supply and return grille. The supply and return grill, is a panel made of lacquered wood which has two grids, a small top (grille) and a larger (inlet grille). The grid serves to ensure a correct distribution of the air, is hooked to the formwork by means of hooks provided as standard. The grille is secured to the formwork by means of bolts supplied as standard.



Bolts for formwork fixing

4.17 Electric connections: preliminary safety information

The electric panel is located inside the unit at the top of the technical compartment where the various components of the refrigerant circuit are also to be found. To access the electrical board, remove the front panel of the unit:

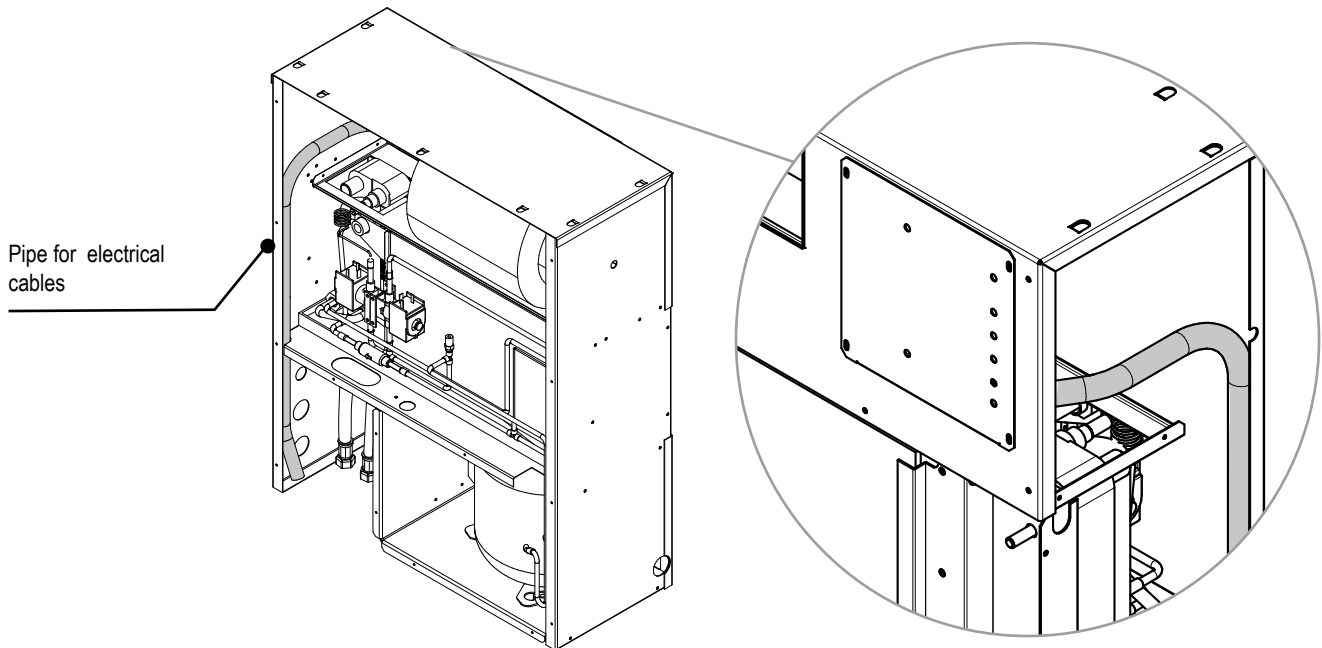

Power connections must be made in accordance to the wiring diagram enclosed with the unit and in accordance to the norms in force.



Make sure the power supply upstream of the unit is (blocked with a switch). Check that the main switch handle is padlocked and it is applied on the handle a visible sign of warning not to operate.



It must be verified that electric supply is corresponding to the unit electric nominal data (tension, phases, frequency) reported on the label in the front panel of the unit.



Power cable and line protection must be sized according to the specification reported on the form of the wiring diagram enclosed with the unit.



The cable section must be commensurate with the calibration of the system-side protection and must take into account all the factors that may influence (temperature, type of insulation, length, etc.).



Power supply must respect the reported tolerances and limits: If those tolerances should not be respected, the warranty will be invalidated.



Flow switches must be connected following the indication reported in the wiring diagram. Never bridge flow switches connections in the terminal board. Guarantee will be invalidated if connections are altered or not properly made.



Make all connections to ground provided by law and legislation.



Before any service operation on the unit, be sure that the electric supply is disconnected.



FROST PROTECTION

If opened, the main switch cuts the power off to any electric heater and antifreeze device supplied with the unit, including the compressor crankcase heaters. The main switch should only be disconnected for cleaning, maintenance or unit repair.

4.18 Electrical data



The line voltage fluctuations can not be more than $\pm 10\%$ of the nominal value, while the voltage unbalance between one phase and another can not exceed 1%, according to EN60204. If those tolerances should not be respected, please contact our Company.

Power supply	V/~ /Hz	230/1/50
Control board	V/~ /Hz	24V
Auxiliary circuit	V/~ /Hz	230/1/50
Fans power supply	V/~ /Hz	230/1/50
Line section	mm ²	1,5
PE section	mm ²	1,5



Electric data may change for updating without notice. It is therefore necessary to refer always to the wiring diagram present in the units.

4.19 Electrical connections

The power supply must correspond to the electric nominal data (tension, phases, frequency) reported on the label in the front panel of the unit. Power connections must be made in accordance to the wiring diagram enclosed with the unit and in accordance to the norms in force. Power cable and line protection must be sized according to the specification reported on the wiring diagram enclosed with the unit.



Electric supply must be in the limits shown: in the opposite case warranty will terminate immediately. Before every operation on the electric section, be sure that the electric supply is disconnected.



The unit can be correctly activated only if the connections of the dehumidification and ventilation remote contacts (example: hygostat, microprocessor control, etc) will be made. In this respect, please, follow very strictly what is reported in the wiring diagram.



FAN SPEED: The unit is provided of a 3-speed fan which is regularly connected to the medium speed. In case it's necessary to change the speed, it's sufficient to change the connection in the block located in the electrical board.



FORCING THE UNIT IN ONLY VENTILATION: in the terminal board, it's available a contact which allow the unit to work in only ventilation. Closing this contact, only the fan works. The dehumidification mode is not in function.

4.19.1 Remote wiring connections (compulsory)



The numbers of terminals block may change without notice. For links is therefore necessary to ALWAYS make the wiring diagram supplied along with the unit.

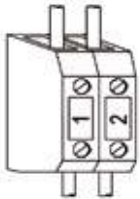

REMOTE ON / OFF (Only WZ versions)

To switch the unit on or off from remote control.

Use voltage free contacts.

The units are supplied as standard from the factory with bridged terminals.

Contact closed, unit ON,

Contact open, unit OFF.

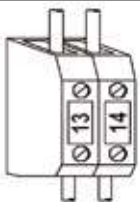

REMOTE SUMMER / WINTER CHANGE OVER (Only WZ versions)

It is used for remote switching summer / winter

The units are supplied as standard from the factory with no-bridge terminals.

Use voltage free contacts .

Contact closed, unit in WINTER mode,

Contact open, unit SUMMER mode.

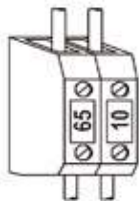
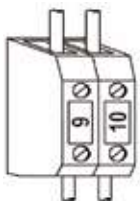

AMBIENT HYGROSTAT (UA) e AMBIENT THERMOSTAT (TA)

Ambient Hygrostat connected to terminal 9, ambient thermostat connected to the terminal 65.

Summer mode functionality

Terminal 9 closed, 65 open: Unit in dehumidification mode with neutral air.

Terminal 65 closed : unit in dehumidification mode with cooling.

Terminal 9 open, 65 open: unit in stand-by

Winter mode functionality

Terminal 9 closed: unit in dehumidification mode with heating

Terminal 65 closed: unit in ventilation mode (see below)

The units are supplied as standard from the factory with no-bridge terminals.

4.19.2 Remote wiring connections (optional)

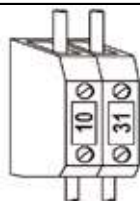

FAN FORCED

It is used to force the unit in ventilation mode only.

Terminal are free voltage.

Terminal closed fan forced ON

Terminal open fan forced OFF

The units are supplied as standard from the factory with no-bridge terminals.

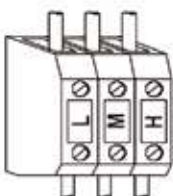

FAN SPEED

The unit is equipped with a three-speed fan, factory wired at medium speed.

To vary the rotation fan speed , move:

Cable n. 18 connected at L: LOW SPEED

Cable n. 18 connected at M: MEDIUM SPEED

Cable n. 18 connected at H: HIGH SPEED

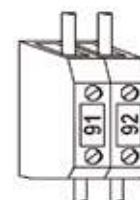

GENERAL ALARM

It is used to remote unit general alarm.

Terminal closed: Unit alarm IN

Terminal open: unit WORKING

5. UNIT START UP

5.1 Preliminary checks

Before starting the unit the checks detailed in this manual of the electric supply and connections, the hydraulic system and the refrigerant circuit, should be performed.



Start-up operations must be performed in accordance with the instructions detailed in the previous paragraphs.

5.1.1 Before start-up



Damage can occur during shipment or installation. It is recommended that a detailed check is made, before the installation of the unit, for possible refrigerant leakages caused by breakage of capillaries, pressure switch connections, tampering of the refrigerant pipework, vibration during transport or general abuse suffered by the unit.

- Verify that the unit is installed in a workmanlike manner and in accordance with the guidelines in this manual.
- Check that all power cables are properly connected and all terminals are correctly fixed.
- The operating voltage the one shown on the unit labels.
- Check that the unit is connected to the system earth.
- Check that there is no refrigerant leakage.
- Check for oil stains, sign of a possible leak.
- Check that the refrigerant circuit shows the correct standing pressure on the pressure gauges (if present) otherwise use external ones.
- Check that the Schrader port caps are the correct type and are tightly closed.
- Check that all water connections are properly installed and all indications on unit labels are observed.
- The system must be flushed, filled and vented in order to eliminate any air.
- Check that the water temperatures are within the operation limits reported in the manual.
- Before start up check that all panels are replaced in the proper position and locked with fastening screws.



Do not modify internal wiring of the unit as this will immediately invalidate the warranty.

5.2 Wiring diagram

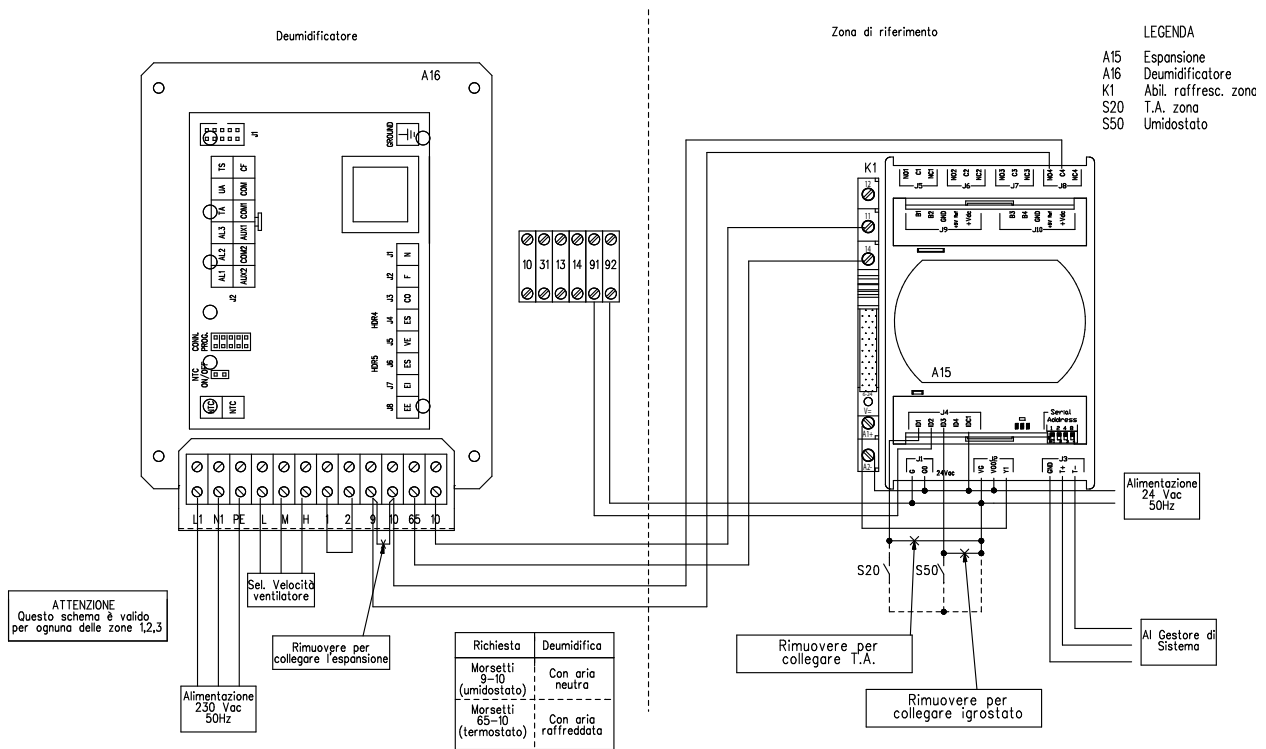



5.3 Control panel

Icon	Meaning
	Electrical supply (green): indicates that green switch has been turned in On position and the unit is electrically supplied.
	Compressor led (green): indicates compressor status with the following meanings: led ON: compressor running; led blinking: compressor time delay to start;
	Alarm led (red): indicates the unit alarm status Red led ON or blinking: see paragraph 6.4
	Defrost led (yellow): indicates that the units is executing the defrost cycle; led fastly blinking: execution of drop cycle at the defrost end;

6. USE

6.1 Unit switch on and first start up

Place the main line switch (not supplied) to ON. In the case of hygrostat call the fan is activated, and the request to start the compressor (delayed by 3 minutes) is activated too. During this period the compressor LED  stops flashing). The unit work in cyclic mode by activating the compressor for 40 minutes of running and 12 minutes in defrost mode (during the defrost LED  flashes).



6.2 Stop

To switch off the unit place the main line in OFF.

6.3 Stand-by

When the unit is switched off from the hygrostat a/o thermostat the unit will be than in standby mode. In this mode, the only visible signs are the green power LED. .

6.4 Displaying during an alarm

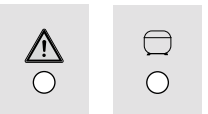
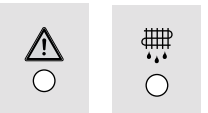
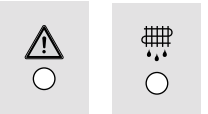
Icon	Meaning	Cause	Solution
 Steady red LED.	High pressure alarm. Reset is automatic if the alarm occurs no more than three times an hour. More than three times an hour the alarm becomes manual reset. To reset it simply remove and restore power.	Low air flow. Clogged filter. Low water level. High Water temperature.	Restore the correct air flow, check the ducts pressure drop. Clean the filter. Restore the correct water temperature.
 Flashing red light.	Low pressure alarm. This alarm is delayed by 60 seconds. Reset is automatic if the alarm occurs no more than three times an hour. More than three times an hour the alarm becomes manual reset. To rest it simply remove and restore power..	High water flow Low water temperature	Restore the correct water flow Restore the correct water temparature
 Red and green LED flashing simultaneously.	Thermal alarm compressor. This alarm is always a manual reset.	Possible refrigerat circuit damage.	Please contact servive center.
 Led red and yellow flashing simultaneously.	Alarm defrost termination for exceeding the time limit.	Low ambient temperature Gas discharge unit	Restore the correct ambient temperature Please contact servive center.
 LED alternately flashing red and yellow.	NTC sensor error alarm.	PTC probe sensor damage	Please contact servive center.

7. MAINTENANCE OF THE UNIT

7.1 General warnings

Maintenance can:

- Keep the equipment operating efficiently
- Prevent failures
- Increase the equipment life



It is advisable to maintain a record book for the unit which details all operations performed on the unit as this will facilitate troubleshooting.



Maintenance must be performed in compliance with all requirements of the previous paragraphs.



Use personal protective equipment required by regulations as compressor casings and discharge pipes are at high temperatures. Coil fins are sharp and present a cutting hazard.

7.2 Drive access

Access to the unit once installed, should only be possible to authorized operators and technicians. The owner of the equipment is the company legal representative, entity or person owns the property where the machine is installed. They are fully responsible for all safety rules given in this manual and regulations.

7.3 Periodical checks



The start-up operations should be performed in compliance with all requirements of the previous paragraphs.



All of the operations described in this chapter **MUST BE PERFORMED BY TRAINED PERSONNEL ONLY**. Before commencing service work on the unit ensure that the electric supply is disconnected. The top case and discharge line of compressor are usually at high temperature. Care must be taken when working in their surroundings. Aluminium coil fins are very sharp and can cause serious wounds. Care must be taken when working in their surroundings. After servicing, replace the cover panels, fixing them with locking screws.

7.3.1 Every 6 months:

It is advisable to perform periodic checks in order to verify the correct working of the unit.

- Check that safety and control devices work correctly as previously described.
- Check all the terminals on the electric board and on the compressor are properly fixed.
- Periodically clean the mobile and fixed contacts of the contactors.
- Check that there are no water leaks from the hydraulic circuit.
- Check that the flow switch is working properly, clean the metallic filter installed on the water pipe.
- Clean draining pan and pipeline (monthly).
- Check the state of the finned battery, if necessary clean it with compressed air in the direction opposite to the air flow. If the battery is completely clogged, clean it with a low pressure cleaner, being careful not to damage the aluminium fins.
- Check the mounting and balancing of the fans.

7.3.2 End of seasons or unit switched off:

If one is planning not to use the unit for a long period, the hydraulic circuit must be emptied, so that there is more water in the pipes and in the heat exchanger. This operation is mandatory if, during the seasonal downtime, it is expected that the ambient temperature will fall below the freezing point of the mixture used (typical seasonal operation).

7.4 Refrigerant circuit repair



In the case that refrigerant circuit should be discharged, all the refrigerant must be recovered with proper machines

The system must be charged with nitrogen, using a gas bottle with a pressure reducing valve, until 15 bar pressure is reached. Any eventual leakage must be searched with a bubble leak finder. In case bubbles appear discharge the circuit before welding with proper alloys.



Never use oxygen instead of nitrogen: explosions may occur.

Site assembled refrigerant circuits must be assembled and maintained carefully, in order to prevent malfunctions.

Therefore:

- Avoid oil replenishment with products that are different from that specified and that are pre-loaded into the compressor.
- In the event of a gas leakage on machines using refrigerant R134A, R410A even if it is only a partial leak, do not top up. The entire charge must be recovered, the leak repaired and a new refrigerant charge weighed in to the circuit.
- When replacing any part of the refrigerant circuit, do not leave it exposed for more than 15 minutes.
- It is important when replacing a compressor that the task be completed within the time specified above after removing the rubber sealing caps.
- When replacing the compressor following a burn out, it is advisable to wash the cooling system with appropriate products including a filter for acid.
- When under vacuum do not switch on the compressor.

8. DECOMMISSIONING

8.1 Disconnect the unit



All decommissioning operations must be performed by authorized personnel in accordance with the national legislation in force in the country where the unit is located.

- Avoid spills or leaks into the environment.
- Before disconnecting the machine please recover:
 - the refrigerant gas;
 - Glycol mixture in the hydraulic circuit;
 - the compressor lubricating oil.

Before decommissioning the machine can be stored outdoors, providing that it has the electrical box, refrigerant circuit and hydraulic circuit intact and closed.

8.2 Disposal, recovery and recycling

The frame and components, if unusable, should be taken apart and sorted by type, especially copper and aluminum that are present in large quantities in the machine.

All materials must be recovered or disposed in accordance with national regulations.

8.3 RAEE Directive (only UE)

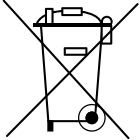

- The RAEE Directive requires that the disposal and recycling of electrical and electronic equipment must be handled through a special collection, in appropriate centers, separate from that used for the disposal of mixed urban waste.
- The user has the obligation not to dispose of the equipment at the end of the useful life as municipal waste, but to send it to a special collection center.
- The units covered by the RAEE Directive are marked with the symbol shown above.
- The potential effects on the environment and human health are detailed in this manual.
- Additional information can be obtained from the manufacturer.

9. DIAGNOSIS AND TROUBLESHOOTING

9.1 Fault finding

All units are checked and tested at the factory before shipment, however, during operation an anomaly or failure can occur.



Regarding the possible remedies, it is strongly recommended an extreme care on what you plan to do: an excessive security may cause serious accidents to inexperienced people, so it is advisable, once you find the cause, ask for our assistance or to qualified technicians.



BE SURE TO RESET AN ALARM ONLY AFTER YOU HAVE REMOVED THE CAUSE OF THE FAULT; REPEATED RESET MAY RESULT IN IRREVOCABLE DAMAGE TO THE UNIT.

Problem	Possible Cause	Corrective Action
The unit doesn't start	Power supply missing	Provide power supply
	Line switch open	Close the main line switch.
	Remote contact opened	Close the contact
	Electronic board defective	Replace defective board
Fan starts, compressor does not start	Compressor thermal protection enabled, compressor defective	Let the compressor cool down, and restart; in case, replace compressor defective
	Electronic board defective	Replace defective board
The unit is powered, the fan does not start	Electronic board defective	Replace defective board

10.DIMENSIONAL DRAWINGS

Dimensional drawing

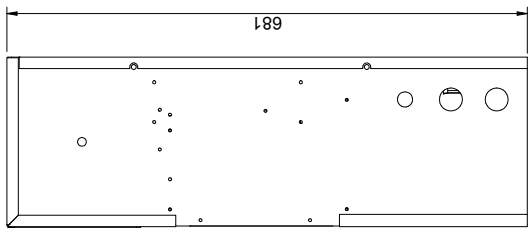
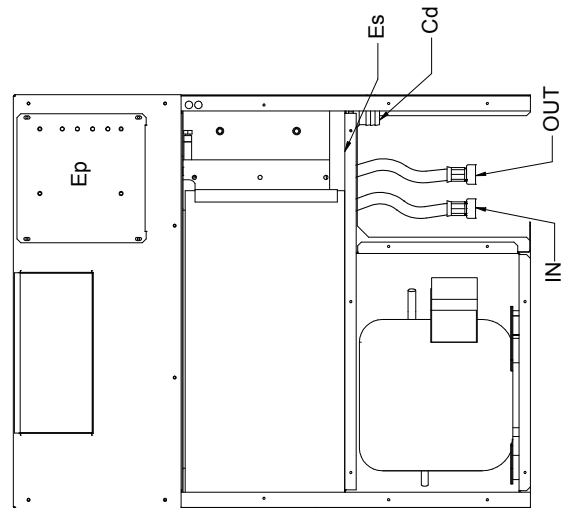
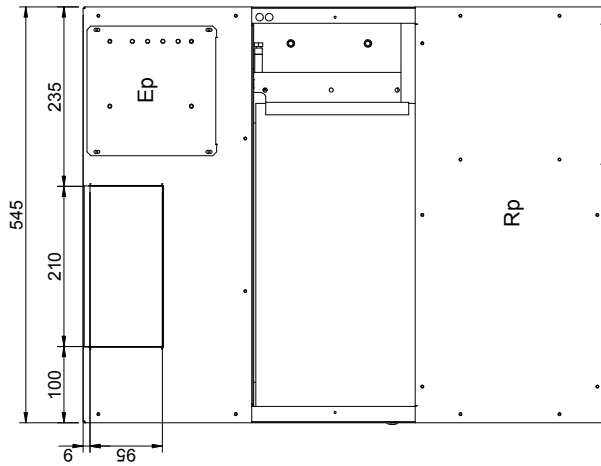
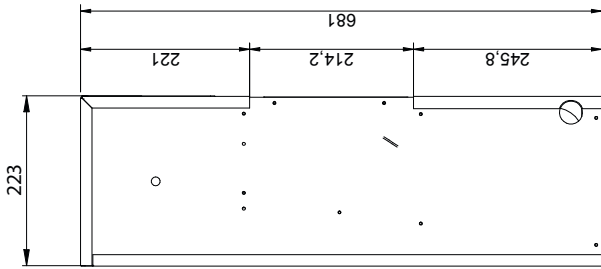
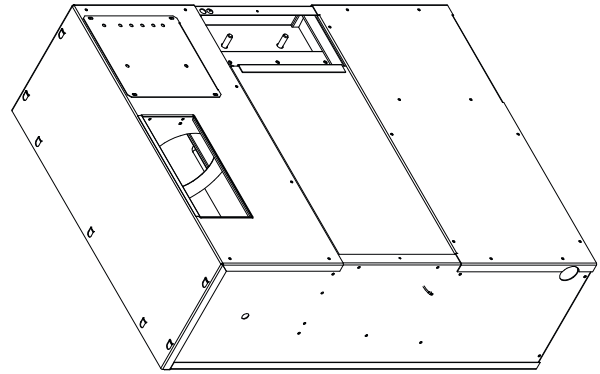

FLUSSO ARIA
AIR FLOW

FLUSSO ARIA
AIR FLOW

WEIGHT OF THE UNIT | 38 Kg

Rp	REMOVABLE PANEL
Ep	ELECRICAL PANEL
Es	POWER SUPPLY DRAIN INLET
Cd	CONDENSATE DRAIN
OUT Ø1/2"GF	USER WATER OUTLET
IN Ø1/2"GF	USER WATER INLET

Dimensional drawing formwork

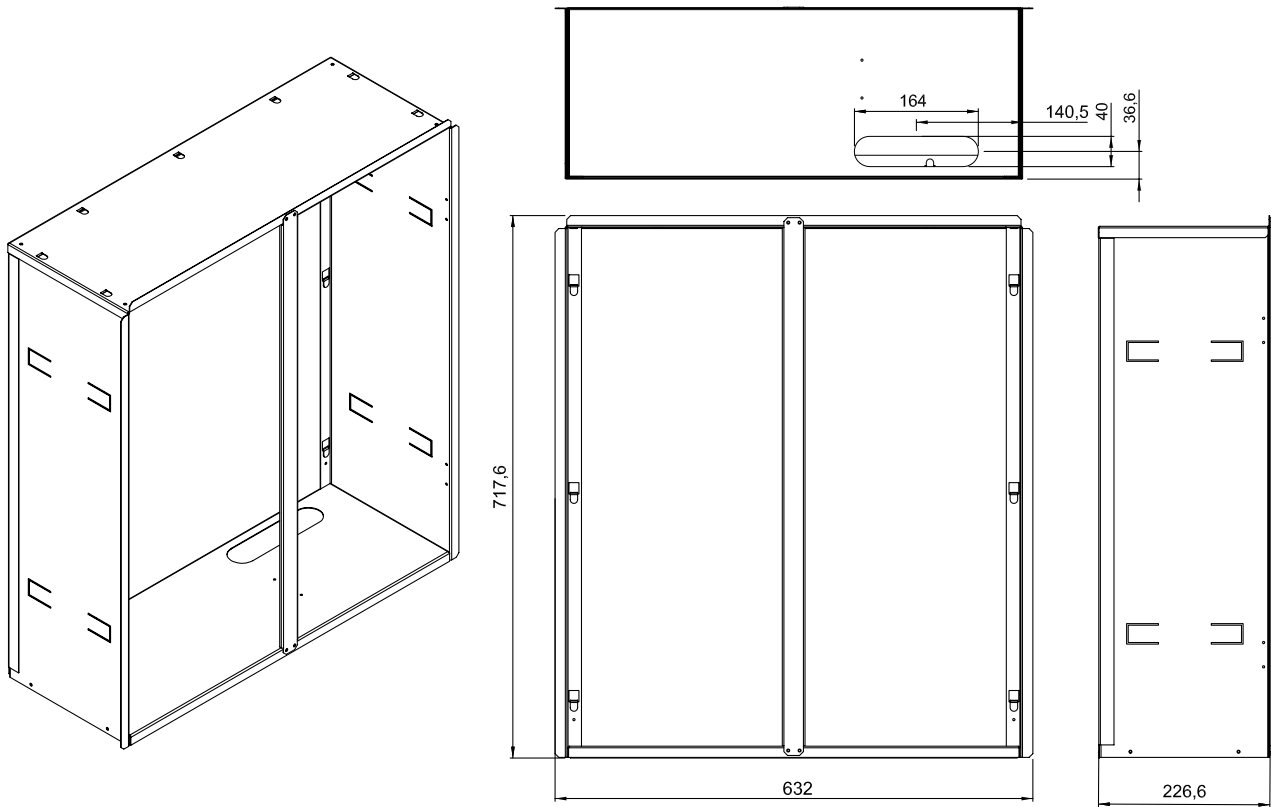

Dimensional drawing supply and return grilles

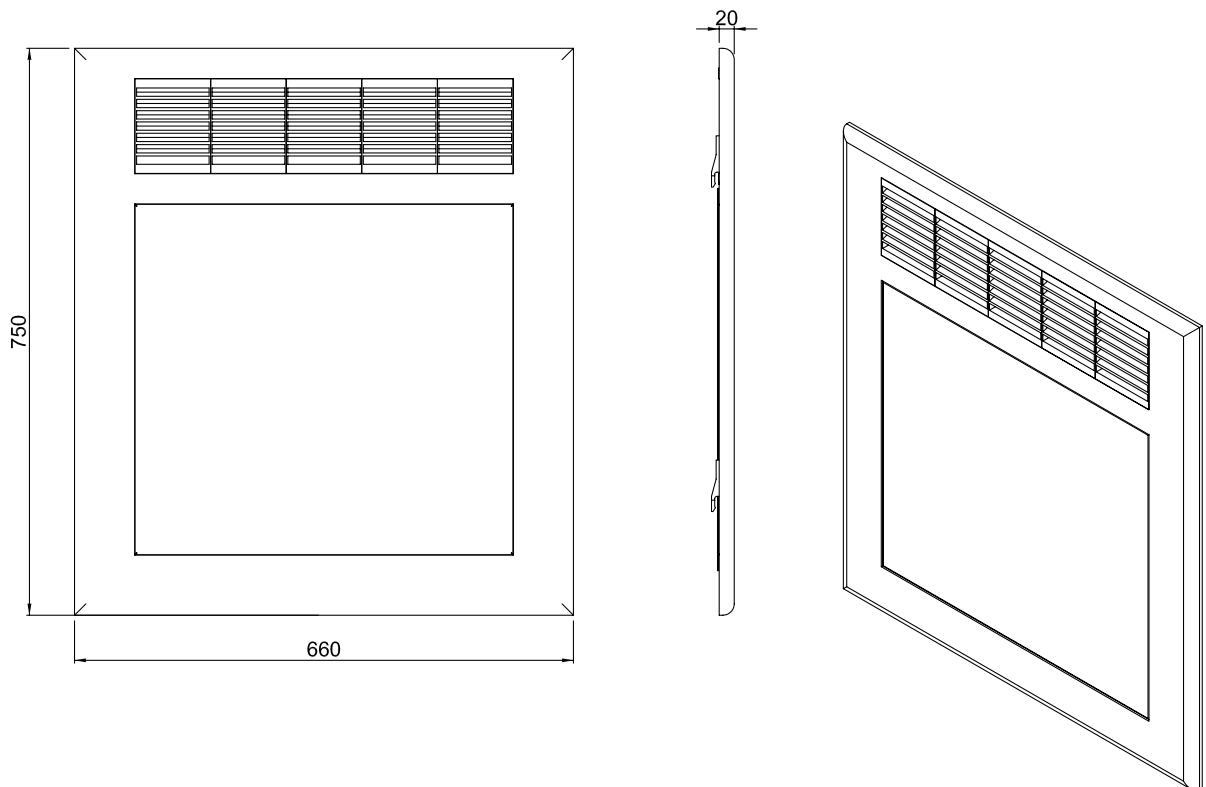

During the service life of the products, performance is affected by external factors, e.g. the hardness of the DHW, atmospheric agents, deposits in the system and so on. The declared data refers to new products that are correctly installed and used in accordance with applicable regulations.

NOTE: correct periodic maintenance is highly recommended.

Follow us on **Immergas Italia**



Immergas TOOLBOX

The App designed by Immergas for professionals



immergas.com

To request further specific details, sector Professionals can also use the following e-mail address: consulenza@immergas.com

Immergas S.p.A.
42041 Brescello (RE) - Italy
Tel. 0522.689011
Fax 0522.680617

ISO 9001 certified company

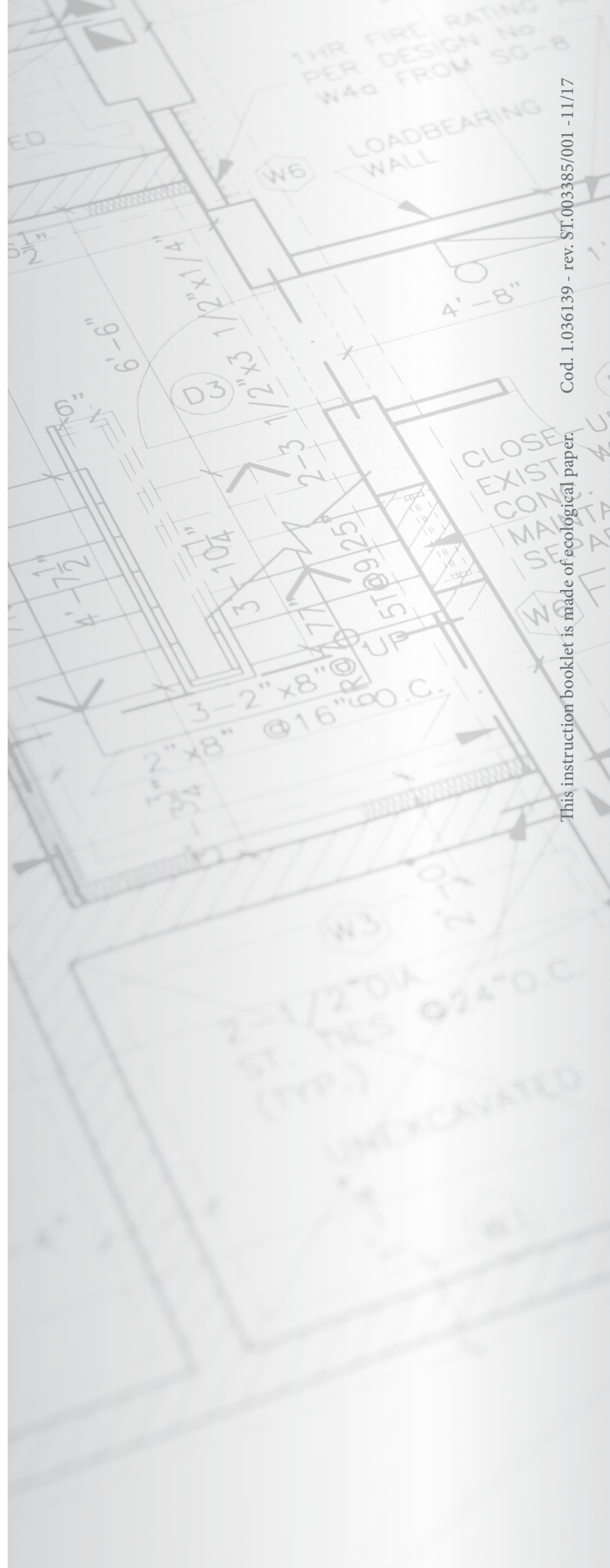

Cod. 1.036139 - rev. ST.003385/001 - 11/17
This instruction booklet is made of ecological paper.