

OWNER'S  
MANUAL

Instruction and IE  
warning book

 **IMMERGAS**

**VICTRIX PRO**  
**35 - 55 1 I**

\*1.036117ENG\*





## Dear Customer,

Our compliments for having chosen a top-quality Immergas product, able to assure well-being and safety for a long period of time. As an Immergas customer you can also count on a qualified after-sales service, prepared and updated to guarantee constant efficiency of your boiler. Read the following pages carefully: you will be able to draw useful suggestions regarding the correct use of the appliance, the respect of which, will confirm your satisfaction for the Immergas product.

Contact our area authorised after-sales centre as soon as possible to request commissioning. Our technician will verify the correct functioning conditions; he will perform the necessary calibrations and will demonstrate the correct use of the generator.

For assistance and scheduled maintenance contact Authorised Immergas After-Sales centres: they have original spare parts and are specifically trained directly by the manufacturer.

## General recommendations

All Immergas products are protected with suitable transport packaging.

The material must be stored in dry environments protected against bad weather.

The instruction book is an integral and essential part of the product and must be consigned to the new user also in the case of transfer or succession of ownership.

It must be stored with care and consulted carefully, as all of the warnings provide important safety indications for installation, use and maintenance stages.

This instructions manual provides technical information for installing Immergas boilers. As for the other issues related to boiler installation (e.g. safety in the work site, environment protection, injury prevention), it is necessary to comply with the provisions specified in the regulations in force and principles of good practice.

In compliance with legislation in force, the systems must be designed by qualified professionals, within the dimensional limits established by the Law. Installation and maintenance must be performed in compliance with the regulations in force, according to the manufacturer's instructions and by professionally qualified staff, intending staff with specific technical skills in the plant sector, as envisioned by the Law.

Improper installation or assembly of the Immergas appliance and/or components, accessories, kit and devices can cause unexpected problems to people, animals and objects. Read the instructions provided with the product carefully to ensure a proper installation.

Maintenance must be carried out by skilled technical staff. The Immergas Authorised After-sales Service represents a guarantee of qualifications and professionalism.

The appliance must only be destined for the use for which it has been expressly declared. Any other use will be considered improper and therefore potentially dangerous.

If errors occur during installation, operation and maintenance, due to non compliance with technical laws in force, standards or instructions contained in this book (or however supplied by the manufacturer), the manufacturer is excluded from any contractual and extra-contractual liability for any damages and the appliance warranty is invalidated.

For further information regarding legislative and statutory provisions relative to the installation of gas heat generators, consult the Immergas site at the following address: [www.immergas.com](http://www.immergas.com)

## CE DECLARATION OF CONFORMITY

Under the "Gas Appliances" Directive 2009/142/EC, "Electromagnetic Compatibility (EMC)" Directive 2004/108/EC, "Boiler Efficiency" Directive 92/42/EC and "Low Voltage" Directive 2006/95/EC.

The Manufacturer: Immergas S.p.A. v. Cisa Ligure n° 95 42041 Brescello (RE)

DECLARES THAT: Immergas boiler model:

**Victrix Pro 35 - 55 I I**

complies with the same European Community Directives

Mauro Guareschi

Research & Development Director

Signature:

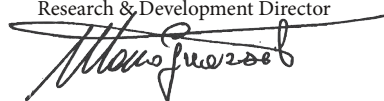

# INDEX

<b>INSTALLER</b>	<b>page</b>	<b>USER</b>	<b>page</b>	<b>MAINTENANCE TECHNICIAN</b>	<b>page</b>
1 Boiler installation .....	5	2 Use and maintenance instructions .....	21	3 Boiler commissioning	
1.1 Installation recommendations .....	5	2.1 Cleaning and maintenance .....	21	(initial check) .....	27
1.2 Position of the appliances. ....	5	2.2 Aeration and Ventilation of the installation		3.1 Hydraulic diagram.....	27
1.3 Aeration and Ventilation of the installation		rooms.....	21	3.2 Wiring diagram.....	28
rooms.....	5	2.3 General warnings.....	21	3.3 Troubleshooting.....	29
1.4 Outdoor installation.....	6	2.4 Control panel.....	22	3.4 Programming the boiler P.C.B. ....	29
1.5 Anti-freeze protection.....	6	2.5 Using the boiler.....	22	3.5 Converting the boiler to other types	
1.6 Main dimensions.....	7	2.6 Troubleshooting.....	24	of gas.....	31
1.7 Gas connection		2.7 Info menu. ....	26	3.6 Checks following conversion to another	
(Appliance category II2H3/P).....	7	2.8 Boiler shutdown. ....	26	type of gas. ....	31
1.8 Hydraulic connection.....	7	2.9 Restoring central heating system		3.7 Heat output check.....	31
1.9 Electric connection.....	8	pressure. ....	26	3.8 Adjustment of the air-gas ratio. ....	31
1.10 Commands for heat adjustment		2.10 System drainage. ....	26	3.9 CH output adjustment. ....	31
(Optional).....	9	2.11 Anti-freeze protection. ....	26	3.10 Output adjustment during DHW (only	
1.11 External temperature probe. ....	9	2.12 Case cleaning.....	26	in combination with an optional external	
1.12 Immergas flue systems. ....	10	2.13 Decommissioning.....	26	storage tank).....	31
1.13 Tables of equivalent length factors. ....	11			3.11 "Chimney Sweep" function.....	31
1.14 Concentric horizontal kit installation....	12			3.12 3-way pump anti-block function	
1.15 Concentric Vertical kit installation. ....	13			(optional).....	32
1.16 Installation of vertical terminals 80 ø. ...	14			3.13 Radiators anti-freeze function.....	32
1.17 Installation of 80 ø horizontal terminals.	15			3.14 Anti-humidity electrode function. ....	32
1.18 Ducting of flues or technical slots. ....	16			3.15 Yearly appliance check and	
1.19 Flue exhaust with boilers in cascade. ....	16			maintenance. ....	32
1.20 System filling. ....	16			3.16 Casing removal. ....	33
1.21 Condensate trap filling.....	16			3.17 Variable heat output. ....	35
1.22 Gas system start-up.....	16			3.18 Combustion parameters. ....	36
1.23 Boiler start up (ignition).....	16			3.19 Technical data.....	37
1.24 Circulation pump.....	17			3.20 Key for Data plate. ....	38
1.25 Kits available on request. ....	17				
1.26 Boiler components.....	18				
1.27 Hydraulic diagram with optional. ....	19				
1.28 Installation examples of individual					
boiler.....	20				

# 1 BOILER INSTALLATION

## 1.1 INSTALLATION RECOMMENDATIONS.

Only professionally qualified heating/plumbing technicians are authorised to install Immergas gas appliances.

Victrix Pro 35 1 I boilers installed in cascade (2 or more) and Victrix Pro 55 1 I boilers in individual or cascade installation can be installed outdoors or in a suitable room.

The installation must comply with all laws and standards in force.

The Victrix Pro 35 1 is also suitable for domestic installations in accordance with the pertinent installation standard.

The place of installation of the appliance and relative Immergas accessories must have suitable features (technical and structural) such to allow (always in safety, efficiency and comfortable conditions):

- installation (according to the provisions of the technical legislation and technical regulations);
- maintenance operations (including scheduled, periodic, routine and special maintenance);
- removal (to outdoors in the place for loading and transporting the appliances and components) as well as their eventual replacement with appliances and/or equivalent components.

**Attention:** these boilers must be used to heat rooms and the like; they are for heating water to a temperature lower than boiling point at atmospheric pressure. Therefore, they must be connected to a heating system that is suitable for their performance and their power.

Before installing the appliance, ensure that it is delivered in perfect condition; if in doubt, contact the supplier immediately.

Packaging materials (staples, nails, plastic bags, polystyrene foam, etc.) constitute a potential hazard and must be kept out of the reach of children. Keep all flammable objects away from the appliance (paper, rags, plastic, polystyrene, etc.).

In the event of malfunctions, faults or incorrect operation, turn the appliance off and contact a qualified company (e.g. the Immergas Technical After-Sales Centre, which has specifically trained staff and original spare parts).

Do not attempt to modify or repair the appliance alone.

Failure to comply with the above implies personal responsibility and invalidates the warranty.

- Installation regulations: these boilers are not in any way designed for installation on bases or floors (Fig. 1-1), but exclusively for wall installation. The wall surface must be smooth, without any protrusions or recesses enabling access to the rear part. Wall mounting of the boiler must guarantee stable and efficient support for the boiler. *The plugs (standard supply) are to be used only in conjunction with the mounting brackets or fixing template to fix the appliance to the wall;* they only ensure adequate support if inserted correctly (according to technical standards) in walls made of solid or semi-hollow brick or block. In the case of walls made from hollow brick or block, partitions with limited static properties, or in any case walls other than those indicated, a static test must be carried out to ensure adequate support. The boilers must be installed in a way to prevent collisions and tampering.

**N.B.: the hex head screws supplied in the blister pack are to be used exclusively to fix the mounting bracket to the wall.**

## 1.2 POSITION OF THE APPLIANCES.

The boilers can be installed:

- outdoors;
- in outdoor environments, also adjoining the building served, located in uncovered space, as long as structurally separated and without walls in common, or situated on the flat covering of the building served, always without walls in common;
- in building also destined for other use or in places inserted in the volume of the building served.

These rooms must be intended exclusively to house CH systems and must have characteristics that comply with legislation in force.

**N.B.:** with Victrix Pro 35 1 I in individual installation it is also possible to set the appliance up in household settings, or similar, in accordance with legislation in force.

**Attention:** the installation of appliances powered with gas with a greater density than 0.8 (L.P.G.) is only allowed in places out of the ground, also communicating with places that are on the ground. In both cases the walkway must not have hollows or depressions such to create gas pockets that determine dangerous conditions.

## Height of the installation room.

*Installation of individual appliance:* the room must have a minimum ceiling height of 2 m.

*Installation of multiple appliances in cascade (2 ÷ 5 Victrix Pro):* considering the size of the boiler, the flue manifold (which must be installed on a 3% gradient) and the hydraulic manifolds, the room must have a minimum ceiling height of 2.3 m.

The aforementioned heights allow for correct installation of the appliances and observe the technical regulations in force.

## Position of the appliances in the room.

*Individual appliance:* the distances between any external point of the boiler and the vertical and horizontal walls of the room must allow accessibility to the regulation, safety and control elements for routine maintenance.

*Multiple appliances, not interconnected, but installed in the same room:* the minimum distance to maintain between several boilers installed on the same wall must be 200 mm, in order to allow accessibility to the regulation, safety and control elements and routine maintenance of all appliances installed.

*Cascade installation (2 ÷ 5 Victrix Pro):* The instructions for correct cascade installation are provided in the respective documents or on the [www.immergas.com](http://www.immergas.com) website in the high power section.

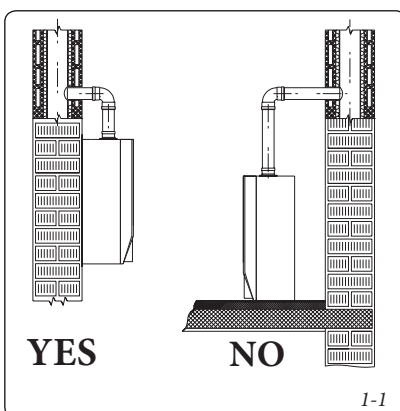

### 1.3 AERATION AND VENTILATION OF THE INSTALLATION ROOMS.

The rooms must have one or more permanent openings for aeration on external walls. The openings used for aeration can be protected using metal grills, meshes and/or rain-proof fins as long as the net aeration surface is not reduced.

**Aeration for installation in outdoor places.** The minimum free surfaces, in relation to the overall heat input must not be below:

- a) above-ground rooms ( $S \geq Q \times 10$ )
  - $S > 350 \text{ cm}^2$  for every Victrix Pro 35 1 I
  - $S > 515 \text{ cm}^2$  for every Victrix Pro 55 1 I
  - (ex: to install 3 Victrix Pro 35 1 I in cascade, the minimum surface is  $350 \times 3 = 1050 \text{ cm}^2$ )
- b) basements and underground rooms up to a height of -5 m from the reference surface ( $S \geq Q \times 15$ ).
  - $S > 525 \text{ cm}^2$  for every Victrix Pro 35 1 I
  - $S > 775 \text{ cm}^2$  for every Victrix Pro 55 1 I
  - (ex: to install 3 Victrix Pro 35 1 I in cascade, the minimum surface is  $525 \times 3 = 1575 \text{ cm}^2$ )
- c) underground rooms at quota between -5 m and -10 m from the reference surface ( $S \geq Q \times 20$  with a minimum of  $5000 \text{ cm}^2$ ).
  - $S > 5000 \text{ cm}^2$  for all configurations

In all cases each opening must not have a net surface area less than  $100 \text{ cm}^2$ .

**Attention:** in the case of installation of appliances powered with gas with greater density than 0.8 (L.P.G.) in outdoor places, above-ground, at least 2/3 of the aeration surface must be flush with the floor, with a minimum height of 0.2 m.

The aeration openings must be at least 2 m for heating capacities not exceeding 116 kW and 4.5 m for higher heating capacities, cavities, depressions or openings communicating with rooms below the walkway surface or draining ducts.

**Aeration for installation in building also destined for other use or in places inserted in the volume of the building served.** The aeration surface must not be less than  $3000 \text{ cm}^2$  in the case of natural gas and must not be less than  $5000 \text{ cm}^2$  in the case of L.P.G..

The installation must comply with the requirements of all relevant codes and standards.

### 1.4 OUTDOOR INSTALLATION.

The boiler has an IPX5D electric insulation rating and can also be installed outdoors, without additional protections.

**Attention:** all optional kits that can be potentially connected to the boiler must be protected on the basis of their electrical protection rating.

### 1.5 ANTI-FREEZE PROTECTION.

**Minimum temperature -5°C.** The boiler comes standard with an anti-freeze function that activates the pump and burner when the system water temperature in the boiler falls below  $5^\circ\text{C}$ . The anti-freeze function is only guaranteed if:

- the boiler is correctly connected to gas and electricity power supply circuits;
- the boiler is powered constantly;
- Main switch is inserted;
- the boiler is not in no ignition block (Par.
- the boiler essential components are not faulty.

*In these conditions the boiler is protected against freezing to an ambient temperature of  $-5^\circ\text{C}$ .*

**Minimum temperature  $-15^\circ\text{C}$ .** If the boiler is installed in a place where the temperature falls below  $-5^\circ\text{C}$  and in the event there is no gas (or the boiler goes into failed ignition block), the appliance can freeze.

*To prevent the risk of freezing follow the instructions below:*

- protect the central heating circuit from freezing by introducing a top quality anti-freeze liquid into this circuit, which is not noxious to health. The instructions of the manufacturer of this liquid must be followed scrupulously regarding the percentage necessary with respect to the minimum temperature at which the system must be kept. An aqueous solution must be made with a potential water pollution class 2 (EN 1717).

*The materials used for the central heating circuit of Immergas boilers withstand ethylene and propylene glycol based antifreeze liquids (if the mixtures are prepared perfectly).*

For life and possible disposal, follow the supplier's instructions.

- Protect the condensate drain trap and relative drain against freezing by using an accessory supplied on request (anti-freeze kit) comprising two electric resistances, the relevant cables and a control thermostat (carefully read the installation instructions contained in the accessory kit pack).

*Boiler anti-freeze protection is thus ensured only if:*

- the boiler is correctly connected to electricity power supply circuits;
- main switch is inserted;
- the anti-freeze kit components are efficient.

*In these conditions the boiler is protected against freezing to temperature of  $-15^\circ\text{C}$ .*

*The warranty does not cover damage due to interruption of the electrical power supply and failure to comply with that stated on the previous page.*



## 1.6 MAIN DIMENSIONS.

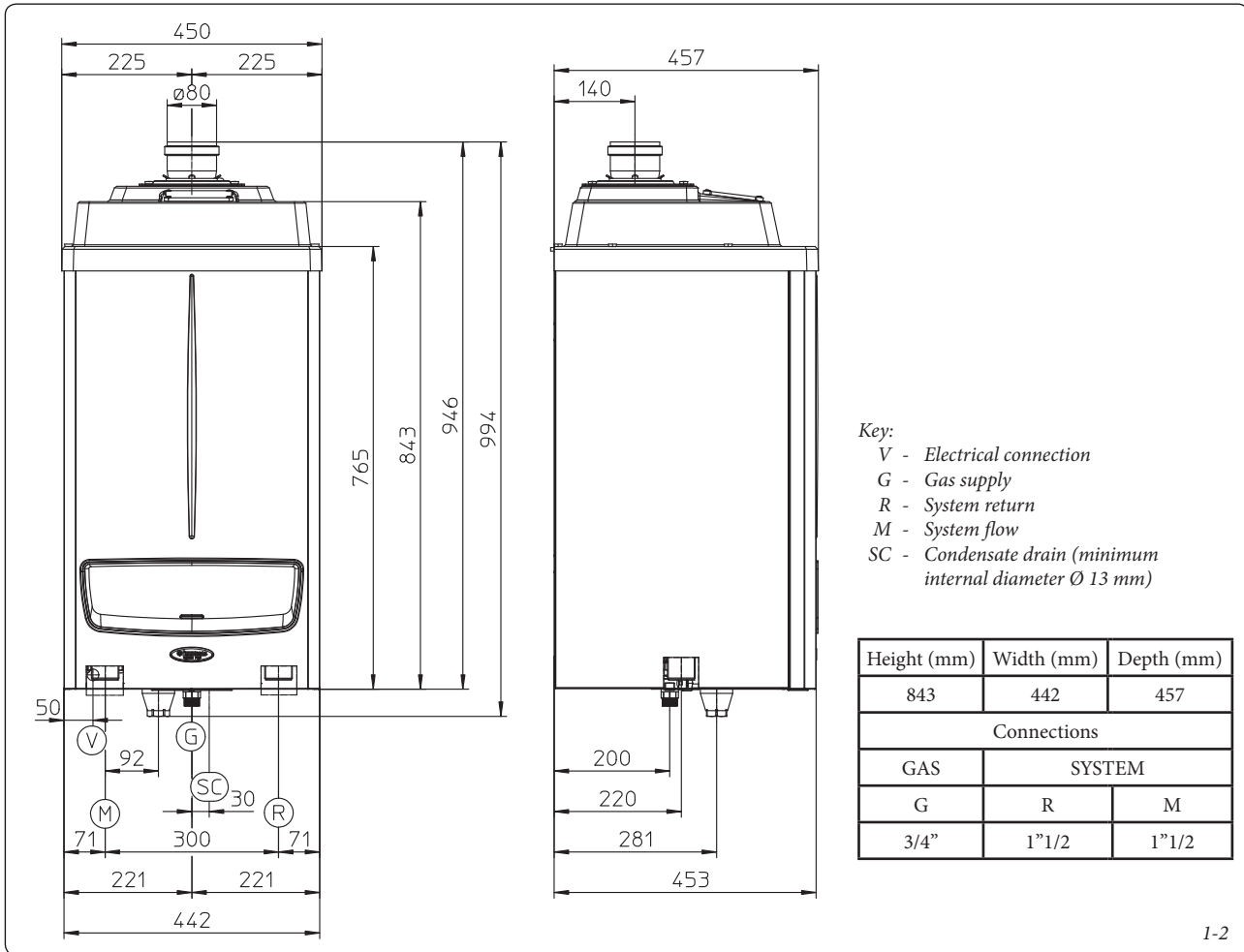

## 1.7 GAS CONNECTION (APPLIANCE CATEGORY II<sub>2H3/P</sub>).

Our boilers are designed to operate with natural gas (G20) and L.P.G. Supply pipes must be the same as or larger than the 3/4" G boiler fitting.

**N.B.:** the gas supply pipe must be suitably dimensioned according to current regulations in order to guarantee correct gas flow to the burner even in conditions of maximum generator output and to guarantee appliance efficiency (technical specifications). The connection to the gas supply must conform to standards.

Before connecting the gas line, carefully clean inside all the fuel feed system pipes to remove any residue that could impair boiler efficiency. Also make sure the gas corresponds to that for which the boiler is prepared (see boiler data-plate). If different, the appliance must be converted for operation with the other type of gas (see converting appliance for other gas types). The dynamic gas supply (methane or L.P.G.) pressure must also be checked according to the type used in the boiler, which must comply with EN 437 and relative attachments and with the local technical regulations in force, as insufficient levels can reduce generator output and cause malfunctions. Ensure correct gas cock connection.

Install a manual cut-off valve with quick closure manoeuvre for 90° rotation and end run stops in the all open or all closed positions on the gas supply pipe in a visible and easily reachable position outside the room where the appliance is installed.

**N.B.:** the internal gas supply system must be built in compliance with the provisions and regulations and all legislation in force, and any other

reference on good technique. If the generator does not exceed the maximum nominal heat input of 35 kW (Victrix Pro 35 I in individual installation) simply follow the provisions set forth in the technical regulation in force.

**Fuel gas quality.** The appliance has been designed to operate with combustible gas free of impurities; otherwise it is advisable to fit special filters upstream of the appliance to restore the purity of the fuel.

**Storage tanks (in case of supply from LPG depot).**

- New LPG storage tanks may contain residual inert gases (nitrogen) that degrade the mixture delivered to the appliance causing problems with boiler operation.
- Due to the composition of the LPG mixture, layering of the mixture components may occur during the period of storage in the tanks. This can cause a variation in the heating power of the mixture delivered to the appliance, with subsequent change in its performance.

## 1.8 HYDRAULIC CONNECTION.

**Attention:** in order not to void the condensation module warranty, before making the boiler connections, carefully wash the CH system (pipes, radiators, etc.) with special pickling or descaling products to remove any deposits that could compromise correct boiler operation.

A chemical treatment of the thermal system water is required, in compliance with the technical standards in force, in order to protect the system and the appliance from deposits (e.g., lime scale), sludge or other hazardous deposits.

It is recommended to prepare a filter in the system to collect and separate any impurities present in the system (slurry remover filter). In order to avoid deposits, scaling and corrosion in the central heating system, the provisions set forth in the technical regulation in force on water treatment in heating systems for civil use must be respected.

Water connections must be made in a rational way using the couplings on the boiler template. The discharge of the boiler safety valve must be connected to a tundish and then the waste should be connected to the sewer. Otherwise, the manufacturer declines any responsibility in case of flooding if the drain valve cuts in.

INSTALLER

USER

MAINTENANCE TECHNICIAN

**Attention:** Immergas declines all liability in the event of damage caused by the inclusion of automatic filling that is not its own brand.

In order to meet the system requirements established by EN 1717 and in observance of local technical regulations in force on the pollution of drinking water, we recommend installing an anti-backflow kit to be used upstream of the cold water inlet connection of the boiler. We also recommend using a category 1, 2 or 3 heat transfer fluid (ex: water + glycol) in the boiler's primary circuit (CH circuit), as defined in standard EN 1717.

**Attention:** to preserve the duration of appliance efficiency features, we recommend the installation of a suitable device for water treatment in presence of water whose characteristics can lead to the deposit of lime scale.

**Condensate drain.** To drain the condensate produced by the appliance, it is necessary to connect to the drainage system by means of acid condensate resistant pipes, with an internal Ø of at least 13 mm. The system connecting the appliance to the drainage system must be carried out in such a way as to prevent freezing of the liquid contained in it. Before appliance start-up, ensure that the condensate can be correctly removed. Also, comply with national and local regulations on discharging waste waters.

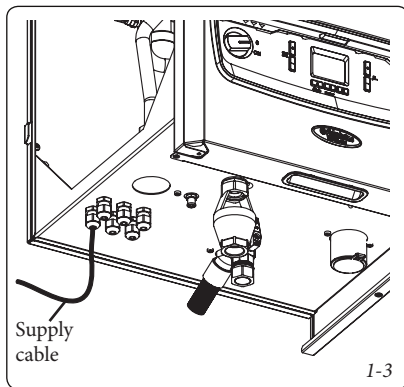

**1.9 ELECTRIC CONNECTION.**

*The operations described below must be performed after after having disconnected the electrical supply from the appliance.*

The electrical system must be built in compliance with technical standards and all legislation in force. The boiler has an IPX5D protection rating for the entire appliance. Electrical safety of the appliance is reached only when it is correctly connected to an efficient earthing system as specified by current safety standards.

**Attention:** Immergas S.p.A. declines any responsibility for damage or physical injury caused by failure to connect the boiler to an efficient earth system or failure to comply with the reference standards.

Also ensure that the electrical installation corresponds to maximum absorbed power specifications as shown on the boiler data-plate.

Boilers are supplied complete with an "X" type power supply cable without plug. The power supply cable must be connected to a 230V ±10% / 50Hz mains supply respecting L-N polarity and earth connection; this network must also have a multi-pole circuit breaker with class III over-voltage category.

The main switch must be installed outside the rooms in a position that is indicated and accessible.

When replacing the power supply cable, contact a qualified company (e.g. the Immergas Authorised After-Sales Technical Assistance Service). The power cable must be laid as shown (Fig. 1-3).

In the event of mains fuse replacement on the connection terminal board, use a 3.15A fast fuse. For the main power supply to the appliance, never use adapters, multiple sockets or extension leads.

**Important:** if the Digital Remote Control is used, arrange two separate lines in compliance with current regulations regarding electrical systems. No boiler pipes must ever be used to earth the electric system or telephone lines. Ensure elimination of this risk before making the boiler electrical connections.

• **Low temperature system installation.** The boiler can directly supply a low temperature system, limiting the value of the "P02" parameter, which defines the generator's flow temperature. In this situation it is good practice to insert a safety device in series with the power supply and boiler. This device is made up from a thermostat with a temperature limit of 55 °C. The thermostat must be positioned on the system flow pipe at a distance of over 2 metres from the boiler.

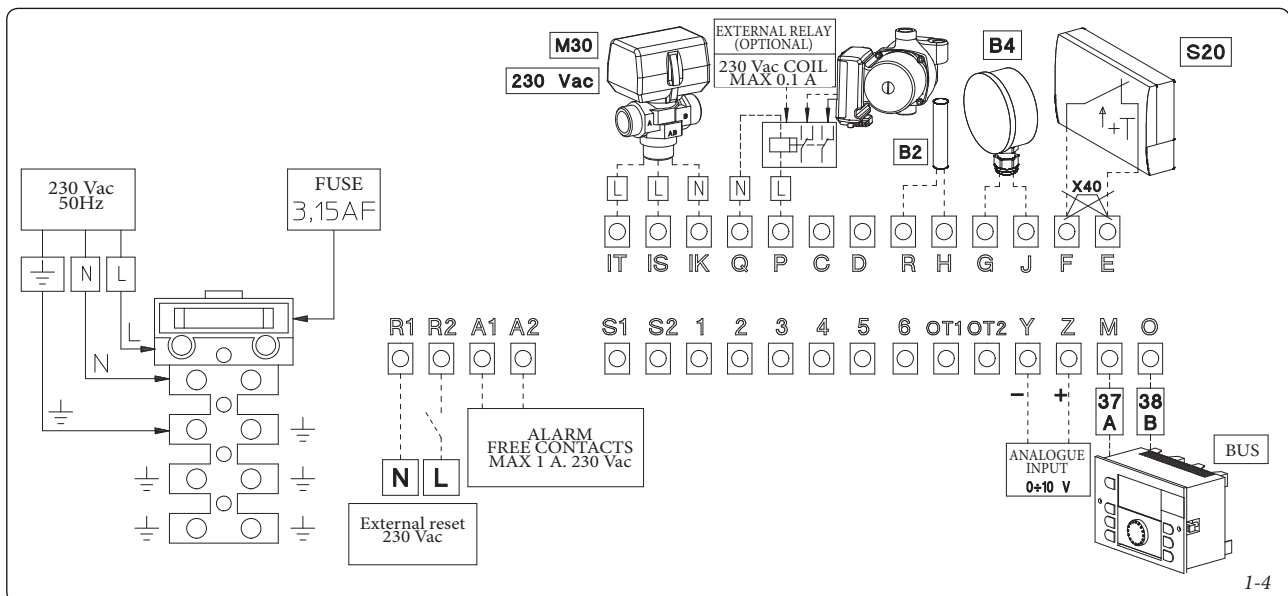



**1.10 OPTIONAL BOILER CONTROLLERS.**

The boiler is prepared for the application of a cascade and zone regulator, zone manager and external probe. These components are available as separate kits to the boiler and are supplied on request. Carefully read the user and assembly instructions contained in the accessory kit.

- The cascade and area regulator (Fig. 1-5) is connected to the boiler using only two wires, powered at 230 V and allows to:
  - manage a hydraulic circuit with 2 mixed zones (mixing valve); 1 direct zone; 1 Storage tank unit and relative pumps;
  - self-diagnosis system to display any boiler functioning anomalies;
  - set two room temperature value: one for daytime (comfort temperature) and one for nighttime (lower temperature);
  - to manage the temperature of the DHW (with a storage tank unit);
  - to manage the boiler flow temperature depending on the external temperature;
  - to select the desired operating mode from the various possible alternatives for each individual hydraulic circuit:
  - permanent operation in comfort temp.;
  - permanent operation in lower temp.;
  - permanent operation in adjustable anti-freeze temp.

- Zone manager (Fig. 1-6). In addition to the functions described in the previous point, the zone manager panel allows to control all the important information regarding operation of the appliance and the heating system with the opportunity of easily intervening on the previously set parameters without having to go to the place where the appliance is installed. The climate chrono-thermostat incorporated into the zone manager enables the system flow temperature to be adjusted to the actual needs of the room being heated, in order to obtain the desired room temperature with extreme precision and therefore with evident saving in running costs. It also allows to display the effective room temperature and the external temperature (if external probe is present). The zone manager is powered directly by the cascade heat adjuster via 2 wires.

**Cascade and zone regulator electric connection or On/off chrono-thermostat (Optional).** Any thermostat or On/Off environment chrono-thermostat must be connected to clamps "E" and "F" eliminating jumper X40 (Fig. 1-4). Make sure that the On/Off thermostat contact is of the "clean" type, i.e. independent of the mains supply, otherwise the P.C.B. would be damaged. Any cascade and zone regulator must be connected by clamps 37 and 38 to clamps "M" and "O" on the connecting terminal board in the boiler, observing the poles and removing jumper X40, (Fig. 1-4) *connection with the wrong polarity prevents the heat adjuster from working, although it will not be damaged.*

**1.11 EXTERNAL TEMPERATURE PROBE.** The boiler is designed for the application of the Room Thermostat (Fig. 1-7), which is available as an optional kit. Refer to the relative instruction sheet for positioning of the external probe. The probe can be connected directly to the boiler electrical system and allows the max. system flow temperature to be automatically decreased when the external temperature increases, in order to adjust the heat supplied to the system according to the change in external temperature. The electric connection of the external probe must take place on clamps G and J on the connection in the boiler (Fig. 1-4). By default, the external probe is not enabled. It is necessary to set parameters "P14" and "P15" for correct operation. The correlation between flow temperature to the system and external temperature is determined by the curves represented in the diagram (parameter "P14") and by setting the offset (parameter "P15") (Fig. 1-8).

**N.B.:** if the external probe is connected to the cascade regulator, boiler parameter "P14" must be set at "0", and external probe control is delegated to the cascade regulator.

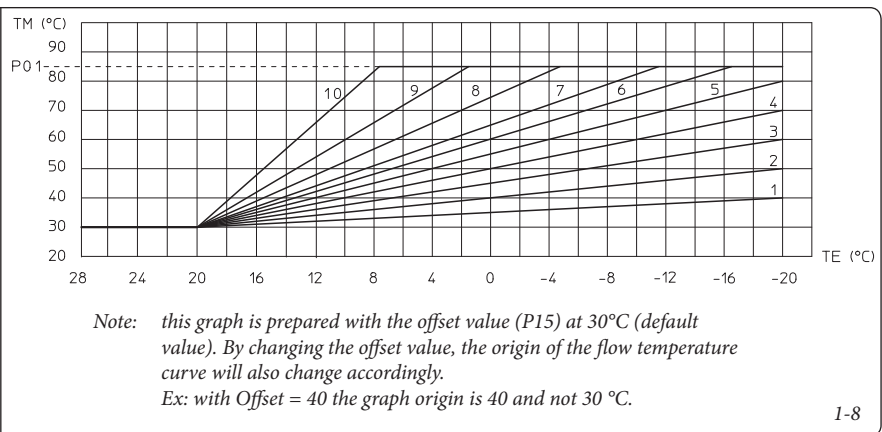
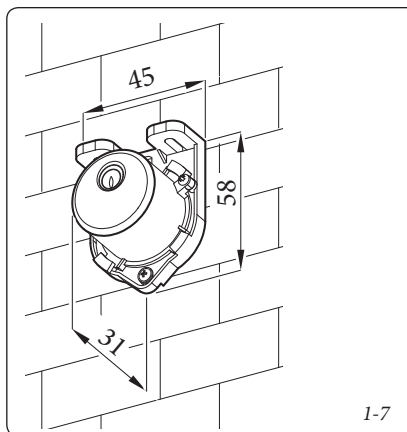
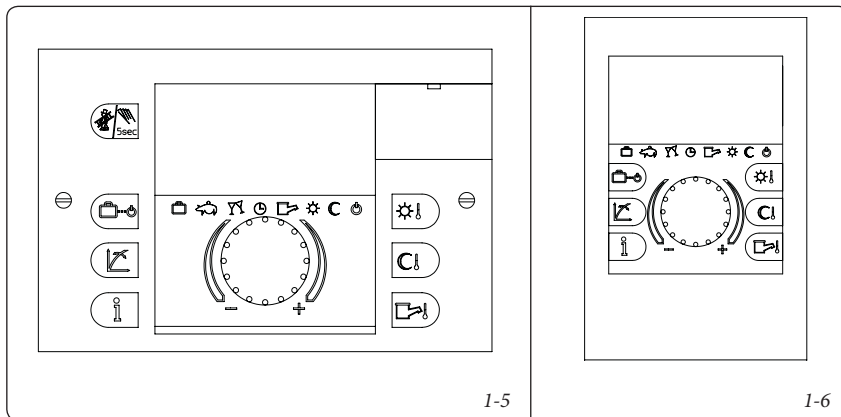

### 1.12 IMMERGAS FLUE SYSTEMS.

Immergas can supply various solutions for flueing and air supply.

**Attention: the boiler must be installed exclusively with an original Immergas “Green Range” air intake device and fumes extraction system, as required by the standard in force.**

The plastic pipes cannot be installed outdoors, for lengths longer than 40 cm, without suitable protection from UV rays and other atmospheric agents.

This system can be identified by an identification mark and special distinctive marking bearing the note: “only for condensing boilers”.

- **Configuration type B, open chamber and fan assisted.** The boiler leaves the factory with type “B<sub>23</sub>” configuration.

Air intake takes place directly from the environment in which the boiler is installed via relevant slots made in the back of the boiler and flue exhaust in the individual flue or to the outside. Boiler with this type of configuration are classified as type B<sub>23</sub> (in accordance with standard EN 297 and relative standards in force).

With this configuration:

- air intake takes place directly from the room in which the appliance is installed;
- the flue exhaust must be connected to its own individual flue or channelled directly into the external atmosphere.
- Type B open chamber boilers must not be installed in places where commercial, artisan or industrial activities take place, which use products that may develop volatile vapours or substances (e.g. acid vapours, glues, paints, solvents, combustibles, etc.), as well as dusts (e.g. dust deriving from the working of wood, coal fines, cement, etc.), which may be harmful for the components of the appliance and jeopardise operation.
- **Type C configuration, sealed chamber and fan assisted.** The boiler leaves the factory with “B<sub>23</sub>” configuration, to change the configuration of the boiler to type “C” (sealed chamber and fan assisted), disassemble the 80 Ø adapter, the bracket and the gasket present on the boiler cover and install the designated flue.
- Coupling extension pipes and concentric elbows. To install push-fitting extensions with other elements of the flue, proceed as follows:

Install the concentric pipe or elbow with the male side (smooth) on the female section (with lip seal) to the end stop on the previously installed element in order to ensure sealing efficiency of the coupling.

**Attention:** if the exhaust terminal and/or concentric extension pipe needs shortening, consider that the internal duct must always protrude by 5 mm with respect to the external duct.

- **N.B.:** for safety purposes, do not obstruct the boiler intake-exhaust terminal, even temporarily.
  - **N.B.:** when installing horizontal pipes, a minimum inclination of 3% must be maintained and a section clamp with pin must be installed every 3 metres.
  - **Maximum extension.** Each individual component has a resistance corresponding to a certain length in metres of pipe with the same diameter (par. 1.13). With installations that involve using various types of parts, deduct the length of the added part from the maximum admissible length of the kit.
- Example: if you need to add a 90° bend to a concentric system 125 Ø you will need to deduct 1.9 m from the maximum admissible length.





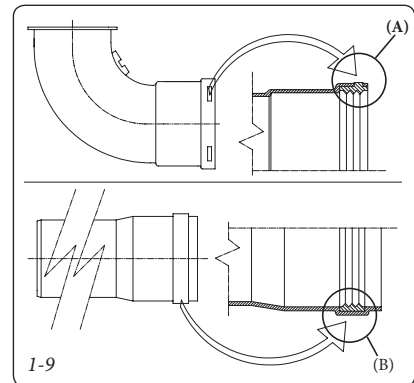

- **Positioning of the gaskets (black) for “green range” flue extraction systems.** Position the gasket correctly (for bends and extensions) (Fig. 1-9):



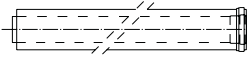

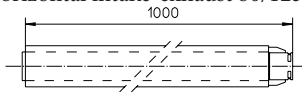
- gasket (A) with notches, to use for bends;
- gasket (B) without notches, to use for extensions;

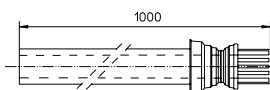
**N.B.:** if component lubrication (already carried out by the manufacturer) is not sufficient, remove the residual lubricant using a dry cloth, then to ease fitting coat the parts with talc, supplied in the kit.

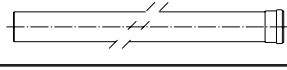
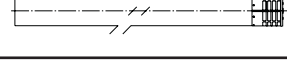

1.13 TABLES OF EQUIVALENT LENGTH FACTORS.

DUCT TYPE	Equivalent length in m of concentric pipe 80/125 Ø
Concentric pipe 80/125 Ø m 1 	1.0 m
Concentric bend 90° 80/125 Ø 	1.9 m
Concentric bend 45° 80/125 Ø 	1.4 m
Terminal complete with concentric horizontal intake-exhaust 80/125 Ø 	5.5 m
Concentric horizontal intake-exhaust terminal 80/125 Ø 	4.7 m
Terminal complete with concentric vertical intake-exhaust 80/125 Ø 	3.4 m
Concentric vertical intake-exhaust terminal 80/125 Ø 	2.7 m

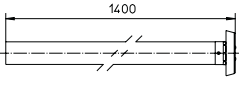
DUCT TYPE	Equivalent length in metres of pipe 80 Ø
Pipe 80 Ø, 1 m 	Exhaust 1.0 m
Complete exhaust terminal 80 Ø, 1 m 	Exhaust 2.6 m
Exhaust terminal 80 Ø 	Exhaust 1.6 m
Bend 90° 80 Ø 	Exhaust 2.1 m
45° 80 Ø Bend 	Exhaust 1.3 m
Terminal complete with vertical exhaust 80 Ø 	Exhaust m 3

INSTALLER

USER

MAINTENANCE TECHNICIAN

### 1.14 CONCENTRIC HORIZONTAL KIT INSTALLATION.

#### Type C configuration, sealed chamber and fan assisted.

Installation of this terminal must comply with the provisions set forth by all of the legislation and regulations in force which may allow, in certain cases, wall flue exhaust for low-NOx condensing boilers.

The position of the terminal (in terms of distances from openings, overlooking buildings, decking, etc.) must be set up in compliance with technical regulations in force as well as the references of good technique (ex.: EN 15287) for generators with a single maximum nominal heat input of 35 kW (ex.: Victrix Pro 35 1 I installed individually) and also for generators with a single maximum nominal heat input of 35 kW.

This terminal is connected directly to the outside of the building for air intake and flue exhaust. The horizontal kit can be installed with the rear, right side, left side or front outlet. For installation with frontal outlet, one must use the fixing plate and a concentric bend coupling in order to ensure sufficient space to carry out the tests required by law upon commissioning.

- External grid. The intake/exhaust terminal, if properly installed, is pleasant to look at on the outside of the building. Make sure that the external silicone sealing plate is properly inserted in the wall.

**Horizontal intake-exhaust kit Ø 80/125 Kit assembly (Fig. 1-10):** install the 80/125 Ø adapter (1) on the central hole of the boiler fully home. Slide the gasket (2) along the adapter (1) up to the relevant groove, fix it to the lid using the previously disassembled sheet steel plate (3). Engage the bend (4) with the male side (smooth) until it is fully home on the adapter (1). Fit the Ø 80/125 (5) concentric terminal pipe with the male end (smooth) to the female end of the bend (4) (with lip seals) up to the stop; making sure that the internal (6) and external wall sealing plates (7) have been fitted, this will ensure sealing and joining of the elements making up the kit.

- Maximum length (MAX L) (Fig. 1-11). The kit with this configuration can be extended up to a *max. measurement of 8.0 m with Victrix Pro 35 1 I and 14.5 m for Victrix Pro 55 1 I*, including the grid-covered terminal and the concentric bend on the boiler outlet.

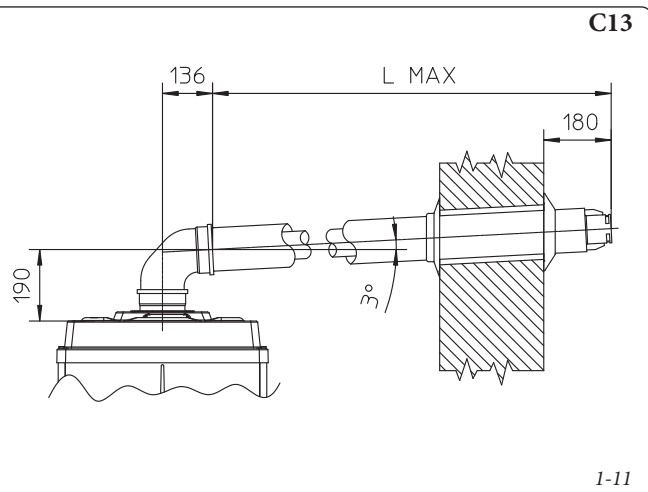
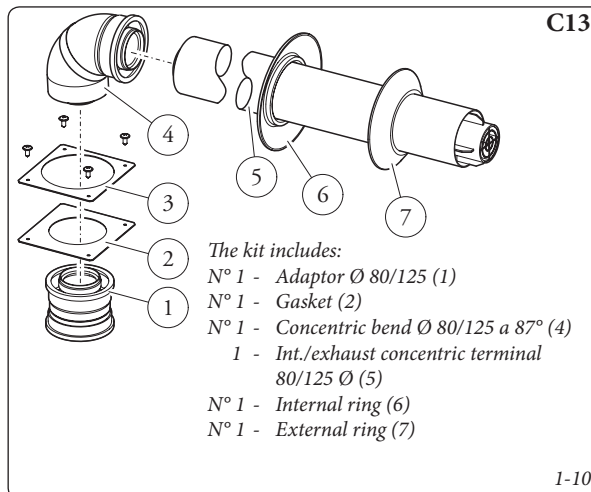

**1.15 CONCENTRIC VERTICAL KIT  
INSTALLATION.**

**Type C configuration, sealed chamber and fan assisted.**

Concentric vertical intake and exhaust kit. This vertical terminal is connected directly to the outside of the building for air intake and flue exhaust.

**N.B.:** the vertical kit with aluminium tile enables installation on terraces and roofs with a maximum slope of 45% (approx. 25°) and the height between the terminal cap and half-shell (260 mm) must always be observed.

**Vertical kit with aluminium tile Ø 80/125.**

Kit assembly (Fig. 1-13): install the 80/125 Ø adaptor (1) on the central hole of the boiler fully home. Slide the gasket (2) along the adaptor (1) up to the relevant groove, Fix it to the lid using the previously-disassembled sheet steel plate (3) Installation of the fake aluminium tile: replace the tiles with the aluminium sheet (5), shaping it to ensure that rainwater runs off. Position the fixed half-shell (6) on the aluminium tile and insert the intake-exhaust pipe (7). Fit the 80/125 Ø concentric terminal pipe with the male end (6) (smooth) to the female end of the adaptor (1) (with lip gasket) up to the stop; making sure that the wall sealing plate (4) has been fitted, this will ensure sealing and joining of the elements making up the kit.

- Maximum length (MAX L) (Fig. 1-13). The kit with this configuration can be extended up to a *max. measurement of 11.5 m with Victrix Pro 35 1 I and 18.0 m with Victrix Pro 55 1 I*, including the terminal.

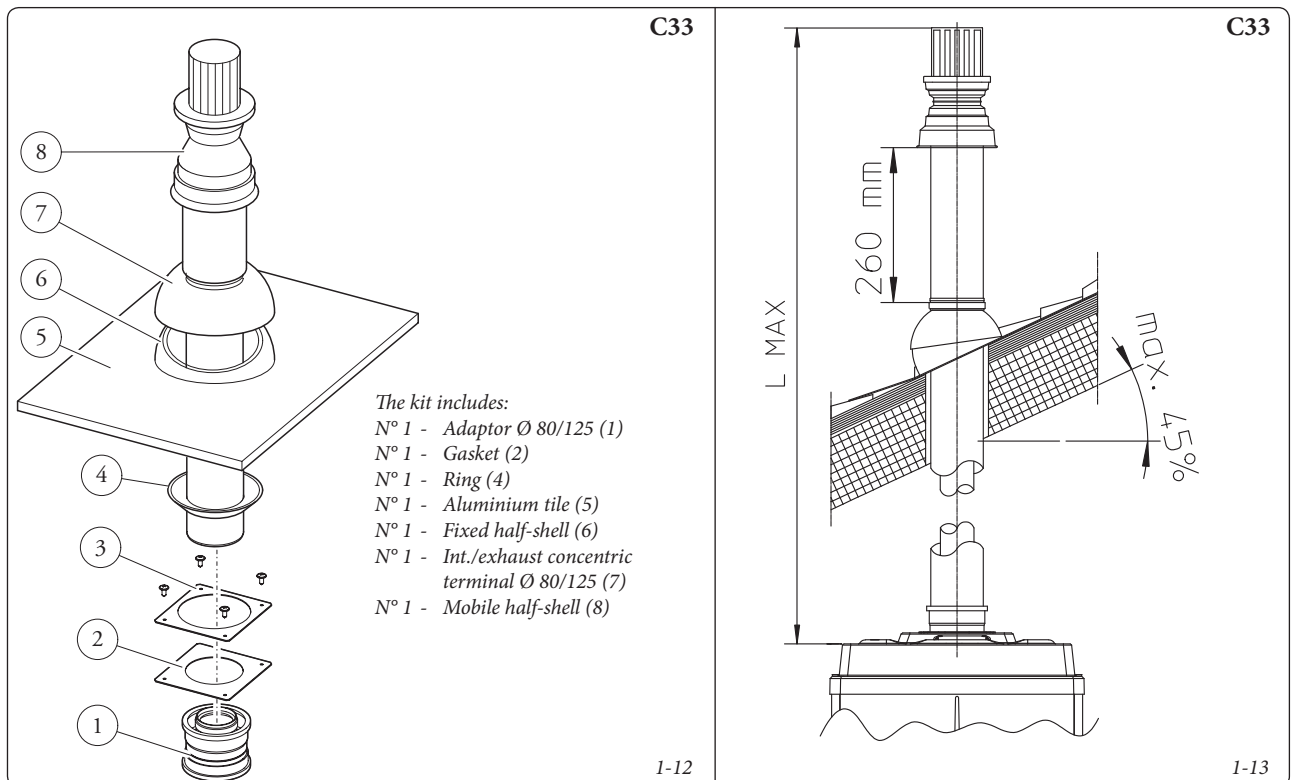

**1.16 INSTALLATION OF VERTICAL TERMINALS 80 Ø.**

**Configuration type B, open chamber and forced draught.**

**80 Ø Vertical kit (plastic for indoor applications).**

Kit assembly (Fig. 1-14): install the 80 Ø terminal (2) on the central hole on the boiler up to stop, making sure that the wall sealing plates (1) have been fitted. This will ensure the sealing efficiency of the kit components.

- Maximum length (MAX L) (Fig. 1-15). The kit with this configuration can be extended up to a *max. measurement of 24.0 m with Victrix Pro 35 1 I and 30.0 m with Victrix Pro 55 1 I*, including the terminal.

Using the Ø 80 vertical terminal for direct discharge of the combustion products, the terminal must be shortened (see quotas fig. 1-16). The wall sealing plate (1) must also be inserted in this case going up to stop on the boiler cover.

**80 Ø Vertical kit (steel for outdoor applications).**

Kit assembly (Fig. 1-17): install the 80 Ø terminal (1) on the central hole on the boiler up to the stop, ensuring the sealing efficiency of the kit components.

The 80 Ø steel terminal is used to install the boiler outdoors with a direct exhaust. The terminal cannot be shortened and once it is installed it will extend out by 630 mm (Fig. 1-18).

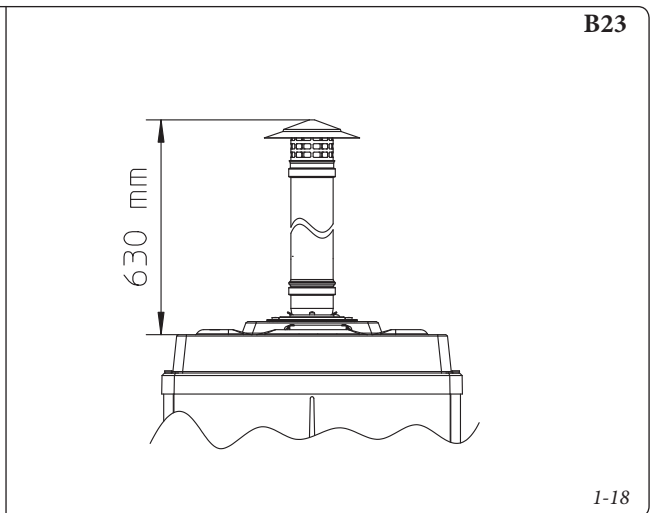
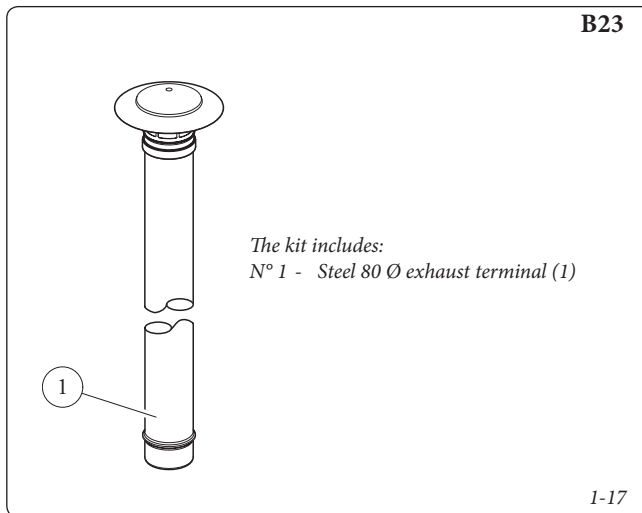
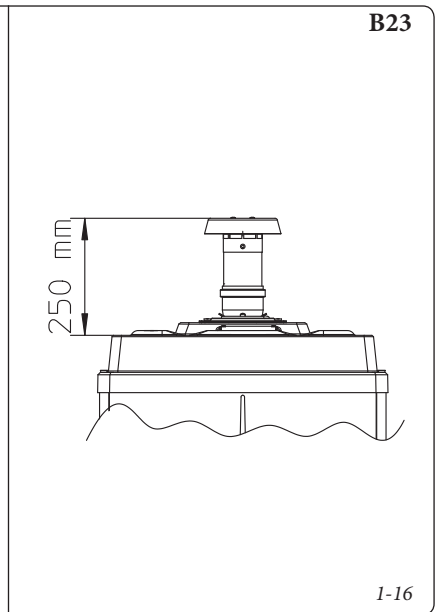
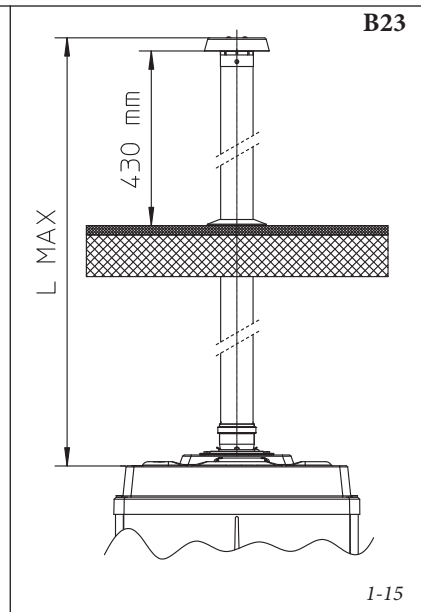
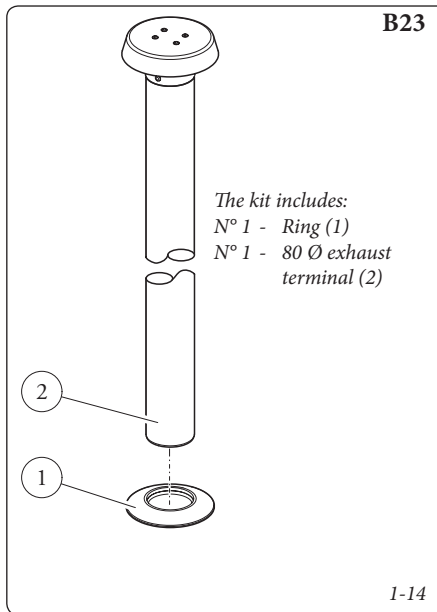



**1.17 INSTALLATION OF 80 Ø  
HORIZONTAL TERMINALS.**

**Configuration type B, open chamber and forced draught.**

**Ø 80 horizontal kit with wall flue exhaust.**

Kit assembly (Fig. 1-19): install the 80 Ø bend (1) with the male side (smooth) fully home on the central hole of the boiler. Fit the exhaust terminal (2) with the male end (smooth) to the female end of the bend (1) up to the stop; making sure that the internal (3) and external (4) wall sealing plate has been fitted. This will ensure sealing and joining of the elements making up the kit.

**Horizontal kit Ø 80 with exhaust in flue.** Kit assembly (Fig. 1-21): install the 80 Ø bend (1) with the male side (smooth) fully home on the central hole of the boiler. Fit the exhaust pipe (2) with the male end (smooth) to the female end of the bend (1) up to the stop; making sure that the internal wall sealing plate (3) has been fitted. This will ensure sealing and joining of the elements making up the kit.

- Maximum length (MAX L) (Fig. 1-20 and 22).  
The kit with this configuration can be extended up to a *max. measurement of 24.0 m with Victrix Pro 35 1 I and 30.0 m with Victrix Pro 55 1 I*, including the terminal.

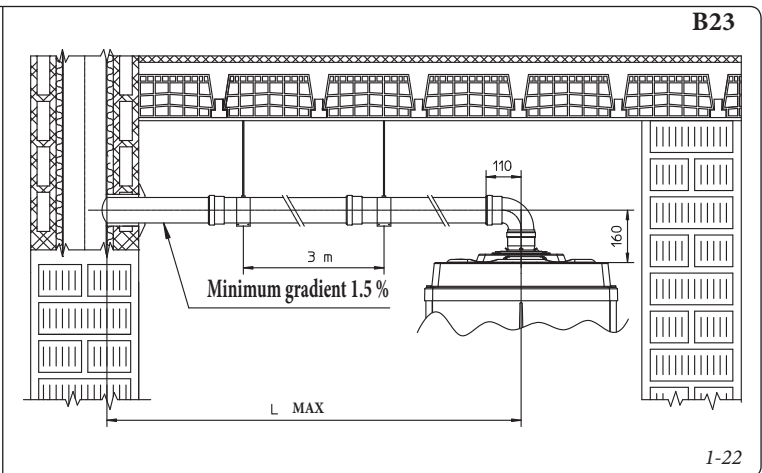
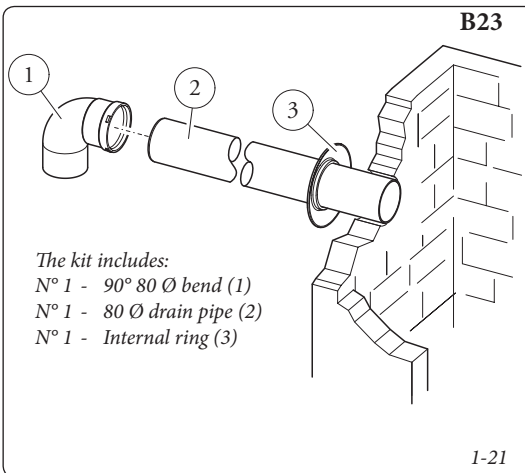
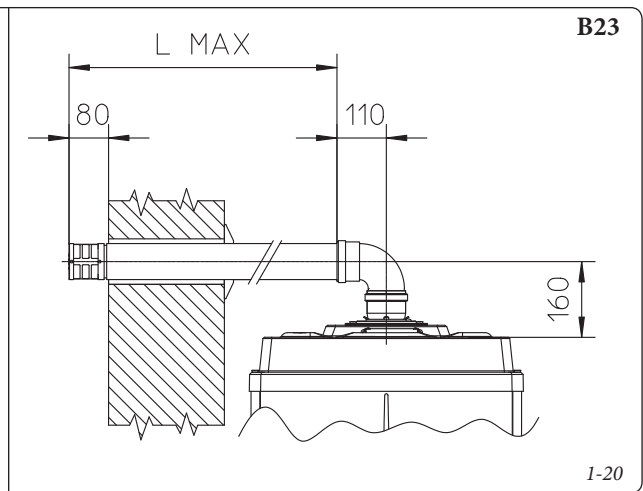
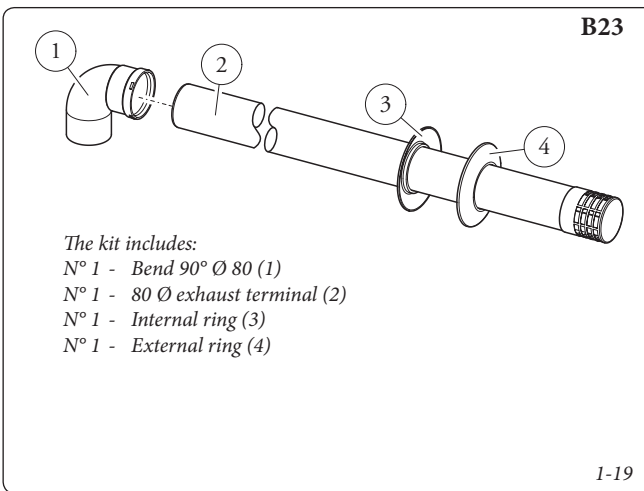

### 1.18 FLUE DUCT SYSTEMS FOR VOIDS AND CHIMNEYS.

Flue ducts may be installed in suitable voids or chimneys provided that the relevant building regulations permit this. Flue ducting systems must be installed in strict accordance with the manufacturers instructions.

**Immergas ducting system Ø 80 .** The "Green Series" 80 Ø flexible ducting system must only be used with Immergas condensing boilers.

In any case, ducting operations must respect the provisions contained in the standard and in current technical regulations; in particular, the declaration of conformity must be compiled at the end of work and on commissioning of the ducted system. The instructions in the project or technical report must likewise be followed, in cases provided for by the standard and current technical regulations. The system or components of the system have a technical life complying with current standards, provided that:

- it is used in average atmospheric and environmental conditions, according to current regulations (in particular, by the standards regarding: absence of combustion products, dusts or gases that can alter the normal thermophysical or chemical conditions; existence of temperatures coming within the standard range of daily variation, etc.).

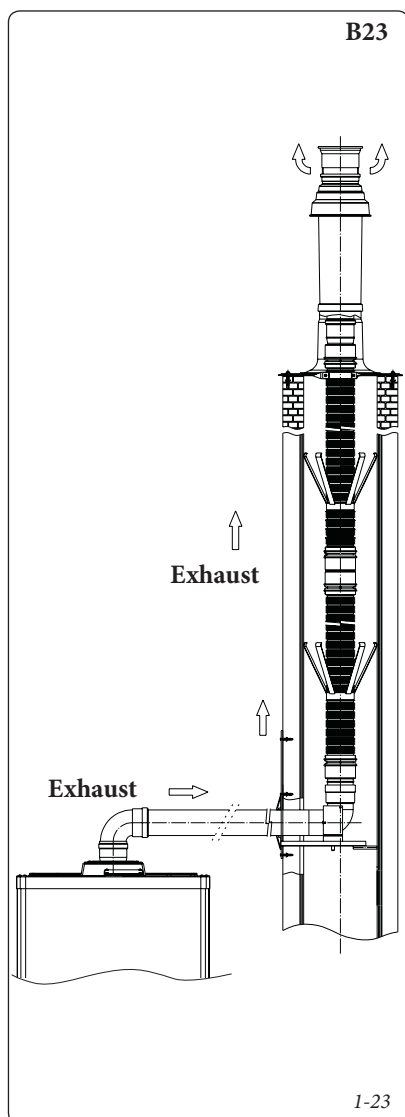

- Installation and maintenance must be performed according to the indications supplied by the manufacturer and in compliance with the provisions in force.
- The max. possible length of the 80 Ø flexible ducting vertical section is equal to 24.0 m for Victrix Pro 35 1 I and 30.0 m for Victrix Pro 55 1 I. This length is obtained considering the complete exhaust terminal, 1m of 80 Ø pipe in exhaust, two 90° 80 Ø bends at the boiler outlet to connect to the ducting system and two direction changes of the flexible tube inside the flue/technical slot.

### 1.19 FLUE EXHAUST WITH BOILERS IN CASCADE.

The boilers installed in cascade composed of any number between 2 and 5 boilers, can be manifolded to a unique flue exhaust pipe, which flows into a flue.

Immergas supplied an appropriate and original flue exhaust system separately to the boilers.

### 1.20 SYSTEM FILLING.

When the boiler has been connected, fill the system. Filling is performed at low speed to ensure release of air bubbles in the water via the boiler and heating system vents.

The boiler incorporates two automatic vent valves fitted on the circulator pump and on the condensing module. Check if the cap is loose. Open the radiator vent valves. Close radiator vent valves when only water escapes from them.

**N.B.:** during these operations start up the circulation pump at intervals, acting on the main switch positioned on the control panel. *Vent the circulation pump by loosening the front cap and keeping the motor running.* Tighten the cap after the operation.

**Attention:** this boiler is **not** equipped with an expansion vessel on the system. It is mandatory to install a closed expansion vessel to guarantee correct boiler operation. The expansion vessel must comply with the European Standards in force. The dimensions of the expansion vessel depend on the data relative to the central heating system. Install a vessel whose capacity responds to the requisites of the Standards in force ("R" collection).

### 1.21 CONDENSATE TRAP FILLING.

On first lighting of the boiler combustion products may come out the condensate drain; after a few minutes' operation check that this no longer occurs. This means that the trap is filled with condensate to the correct level preventing the passage of combustion products.

### 1.22 GAS SYSTEM START-UP.

To start up the system, refer to the technical standard in force: This divides the systems and therefore the start-up operations into three categories: new systems, modified systems, re-activated systems.

In particular, for new gas systems:

- open windows and doors;
- avoid presence of sparks or open flames;
- bleed all air from the pipelines;
- check the seal of the internal system by following the instructions provided by the technical regulations in force (refer to the pertaining local regulations for the "sealing test" on systems served by single or cascade generators with a nominal thermal capacity greater than 35 kW).

### 1.23 BOILER START UP (IGNITION).

In order to issue the Declaration of Conformity required by the regulations in force, one must fulfil the following requirements to commission the boiler (the operations listed below must only be performed by qualified personnel and in the presence of staff only):

- check that the internal system is properly sealed according to the specifications set forth by regulations in force; Up to operating pressures of 40 mbar it is also possible to use the testing method adopted by the technical regulations in force for systems served by single appliances (or in cascade set-up), with nominal thermal capacities greater than 35 kW. For greater pressure levels you will need to refer to legislation in force and/or other effectively tried and tested methods;
- make sure that the type of gas used corresponds to boiler settings;
- check that there are external factors that may cause the formation of fuel pockets;
- switch the boiler on and check correct ignition;
- make sure the fan rpm matches the value provided in the book (Par. 3.17);
- ensure that the safety device intervenes in the event of gas supply failure and check the relative intervention time;
- check activation of the main switch located upstream from the boiler and in the boiler;
- check that the intake/exhaust concentric terminal (if fitted) is not blocked.

The boiler must not be started up even if only one of the checks should be negative.

**N.B.:** the preliminary boiler check must be carried out by an authorised company. The standard boiler warranty is valid from the date of inspection. The test certificate and warranty is issued to the user.

**1.24 CIRCULATION PUMP.**

The "Victrix Pro 1 P" series boilers are supplied with a built-in circulation pump with 3-position electric speed control. The boiler does not operate correctly with the circulation pump on first speed. To ensure optimal boiler operation, in the case of new systems (single pipe and module) it is recommended to use the pump at maximum speed. The circulation pump is already fitted with a capacitor.

**Pump release.** If, after a prolonged period of inactivity, the circulation pump is blocked, unscrew the front cap and turn the motor shaft using a screwdriver. Take great care during this operation to avoid damage to the motor.

**1.25 KITS AVAILABLE ON REQUEST.**

- Cascade and zones heat adjuster kit.
- Support kit for fixing the heat adjuster to the wall.
- Zone manager kit.
- Modulating room thermostat kit.
- External probe kit.
- System flow probe kit.
- DHW probe kit for external storage tank.
- Anti-freeze with -15 °C resistance kit.
- Individual boiler safety devices stub pipes kit.
- Boilers in cascade safety devices stub pipes kit.
- Three-way valve kit for coupling external storage tank unit.
- Individual boiler hydraulic manifold kit.

- Hydraulic connection manifolds kit with two boilers in cascade.
- Additional boiler in cascade hydraulic manifold kit.
- Flue exhaust manifold kit with flue adjusting devices with two boilers in cascade.
- Flue exhaust manifold kit with flue adjusting device with additional boiler in cascade.
- Ø80/125 horizontal concentric kit.
- Ø80/125 vertical concentric kit.
- Ø 80 horizontal kit with flue exhaust.
- 80 Ø horizontal terminal kit with wall flue exhaust.
- Ø80 vertical terminal kit.

The above-mentioned kits are supplied complete with instructions for assembly and use.

**Head available to the system.**

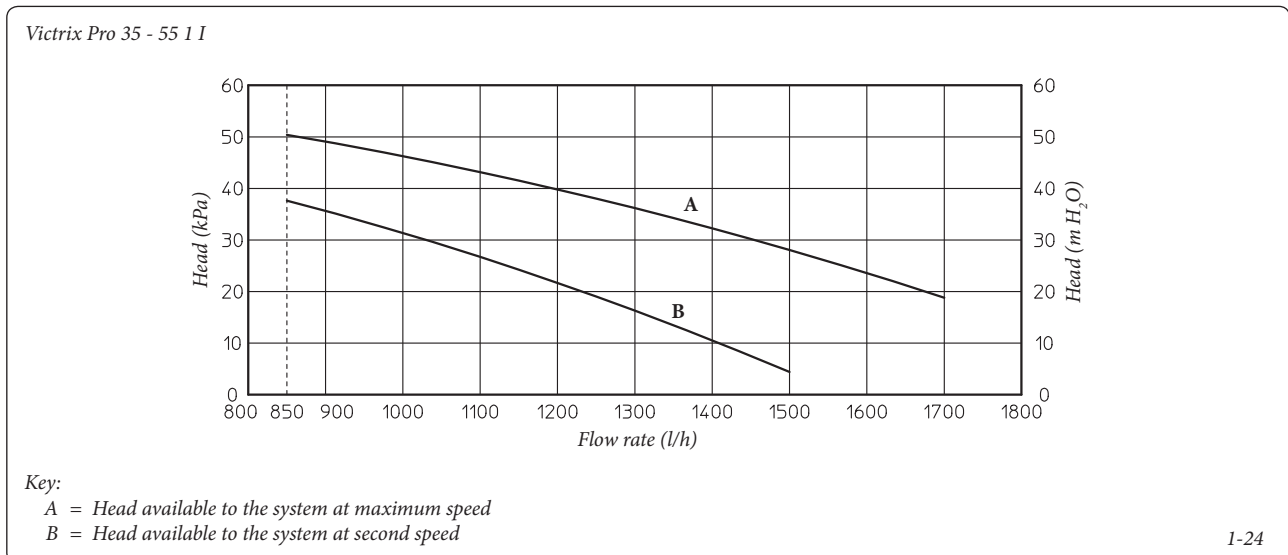

1.26 BOILER COMPONENTS.

INSTALLER

USER

MAINTENANCE TECHNICIAN

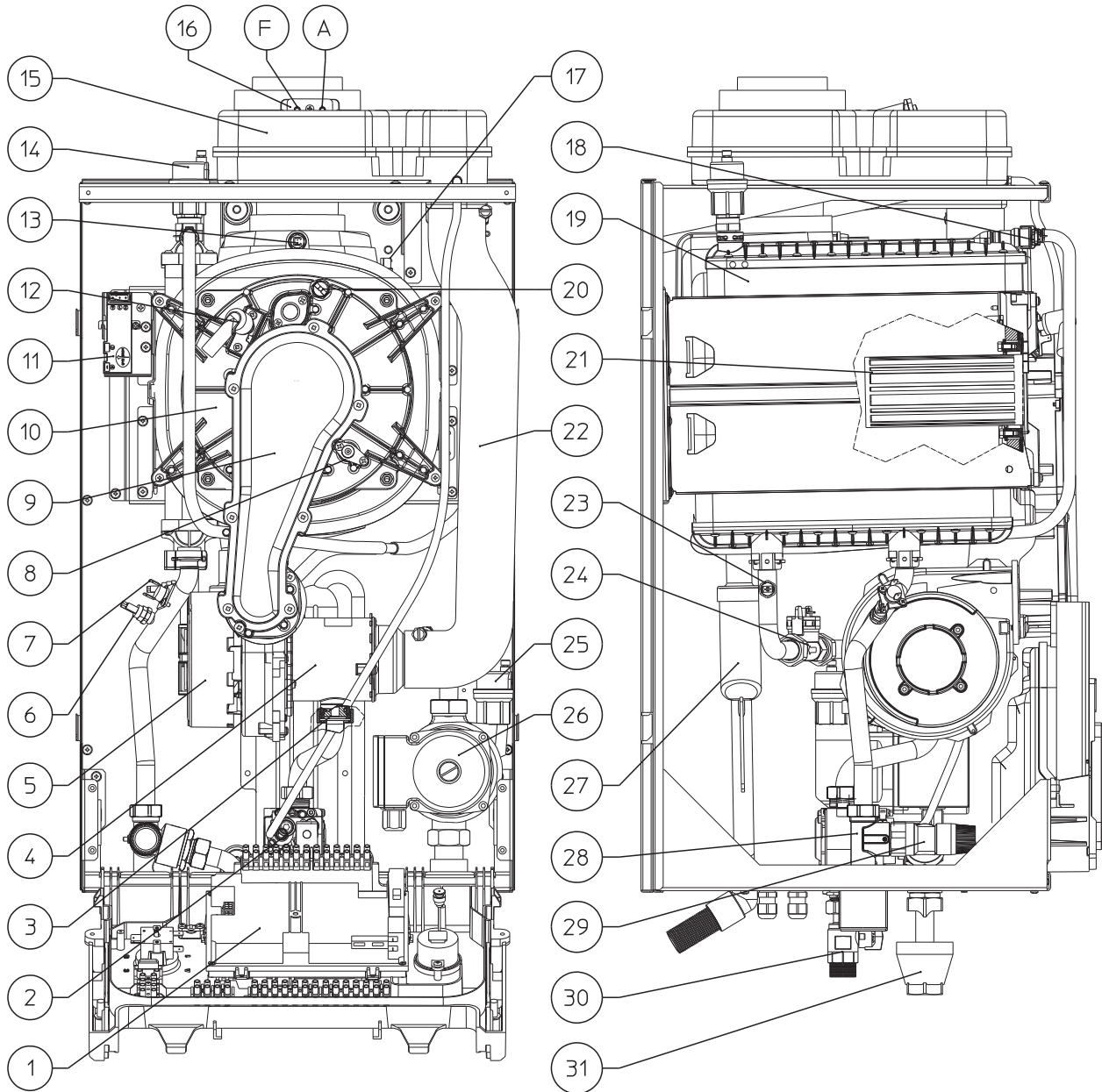

Key:

- 1 - P.C.B.
- 2 - Gas valve
- 3 - Gas nozzle
- 4 - Sleeve with seats for Venturi
- 5 - Air fan
- 6 - System flow regulation NTC probe
- 7 - Overheating safety thermostat
- 8 - Detection electrode
- 9 - Manifold cover
- 10 - Condensation module cover
- 11 - Igniter
- 12 - Ignition electrode
- 13 - Flue probe
- 14 - Condensing module air vent valve
- 15 - Fumes hood

- 16 - Sample points (air A) - (flue gas F)
- 17 - Heat exchanger safety thermal fuse
- 18 - Manual air vent valve
- 19 - Condensation module
- 20 -
- 21 - Burner
- 22 - Air intake pipe
- 23 - System return regulation NTC probe
- 24 - System flow meter
- 25 - Vent valve
- 26 - Pump
- 27 - Condensate trap
- 28 - Flow manifold
- 29 - 4 bar safety valve
- 30 - Gas cock
- 31 - Draining funnel.

1.27 HYDRAULIC DIAGRAM WITH OPTIONAL.

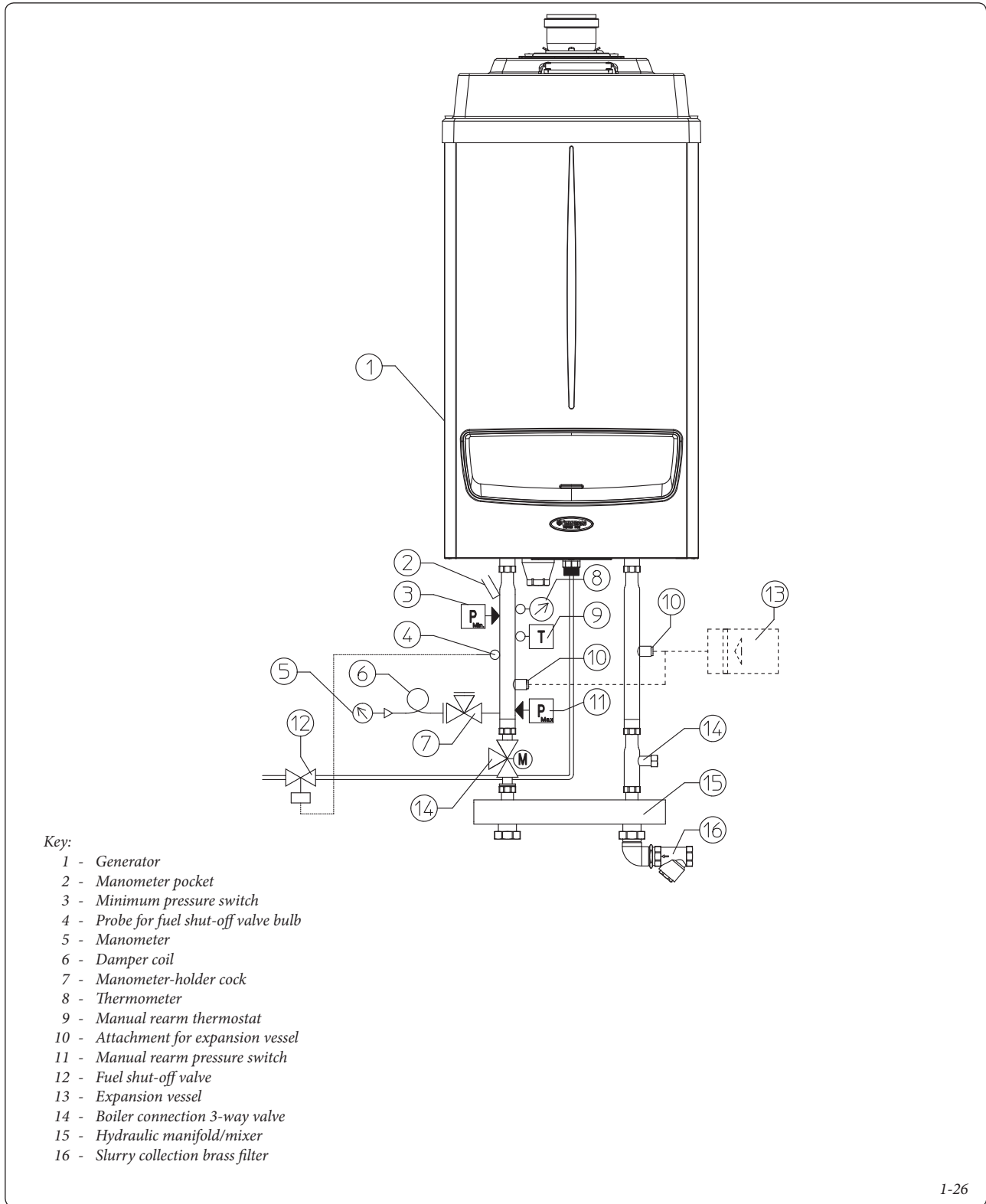

1-26

**Attention:** the sensitive elements of the automatic regulation and block circuit breaker switches and of the thermometer (not supplied as standard with the boiler) must be set-up as described in the installation instructions in compliance with the provisions of the "R" collection. Whenever the generators are not installed in cascade according to the instructions and the Immergas original kits, the sensitive elements must be installed on the flow piping to the central heating system, immersed in the current of water at not more

than 0.5 metres from the boiler outlet. the boilers must be installed in the configurations and with their own original Immergas cascade and safety kits. Immergas S.p.a. declines all liability whenever the installer does not use the devices and Immergas original kits or uses them improperly.

1.28 INSTALLATION EXAMPLES OF INDIVIDUAL BOILER.

- Key:
- 1 - Generator
  - 2 - Cascade and zone regulator
  - 3 - Zone manager
  - 4 - Modulating room thermostat
  - 5 - External probe
  - 6 - Zone 1 temperature probe (CMI-1)
  - 7 - Zone 2 temperature probe (CMI-2)
  - 8 - Common flow probe
  - 9 - Storage tank unit temperature probe
  - 10 - Zone 1 mixing valve (CMI-1)
  - 11 - Zone 2 mixing valve (CMI-2)
  - 12 - Zone 1 central heating circuit pump (CMI-1)
  - 13 - Zone 2 central heating circuit pump (CMI-2)
  - 14 - Zone 3 direct circuit pump (CD)

- 15 - Storage tank unit feeding pump
- 16 - Zone 1 safety thermostat (CMI-1)
- 17 - Zone 2 safety thermostat (CMI-2)
- 19 - Fuel shut-off valve bulb
- 20 - Manometer-holder cock
- 21 - Thermometer
- 22 - Manual rearm thermostat
- 23 - Manual rearm pressure switch
- 24 - Attachment for expansion vessel
- 25 - Expansion vessel
- 26 - Manifold/mixer
- 27 - External storage tank unit
- 28 - Fuel shut-off valve
- 29 - Non return valve
- 30 - Slurry collection system filter
- 31 - Manometer pocket
- 32 - Damper coil
- 33 - Manometer
- 34 - Minimum pressure switch

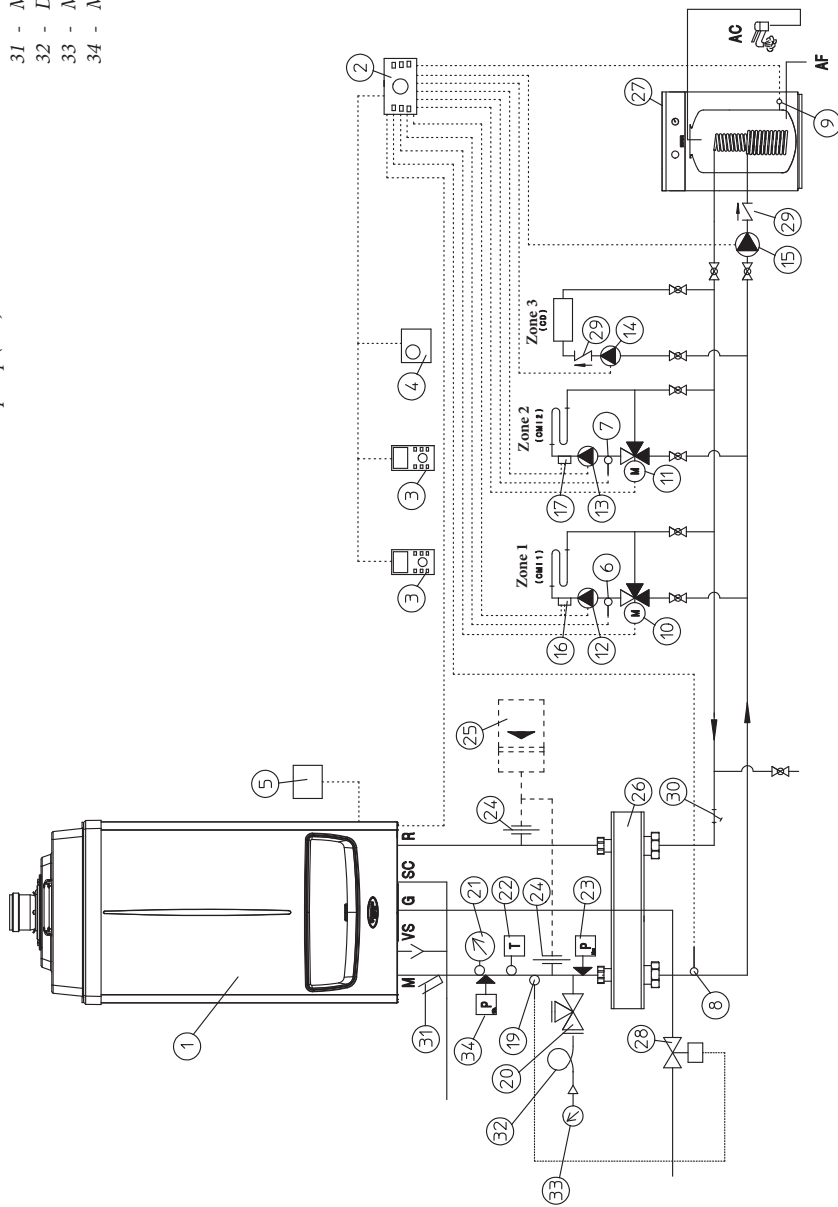



## 2 USE AND MAINTENANCE INSTRUCTIONS

### 2.1 CLEANING AND MAINTENANCE.

**Attention:** the heating systems must undergo periodical maintenance (regarding this, see the section dedicated to the maintenance engineer, relating to "yearly appliance check and maintenance") and regular energy efficiency checks in compliance with national, regional or local provisions in force.

This ensures that the optimal safety, performance and operation characteristics of the boiler remain unchanged over time.

We recommend stipulating a yearly cleaning and maintenance contract with your zone technician

### 2.2 AERATION AND VENTILATION OF THE INSTALLATION ROOMS.

Consult the "Aeration and ventilation of installation rooms" chapter contained herein and, in any case, always refer to the provisions set forth by standards and all legislation in force.

### 2.3 GENERAL WARNINGS.

Use of the boiler by unskilled persons or children is strictly prohibited.

For safety purposes, check that the concentric air intake/flue exhaust terminal (if fitted), is not blocked.

If temporary shutdown of the boiler is required, proceed as follows:

- a) drain the heating system if anti-freeze is not used;
- b) shut-off all electrical, water and gas supplies.

**N.B.:** in the case of maintenance interventions on the boiler that lead to the closure of one or both system cut-off cocks (Fig. 1-30 Ref 34 - 35), the boiler must be off.

In the case of work or maintenance to structures located in the vicinity of ducting or devices for flue extraction and relative accessories, switch off the appliance and on completion of operations ensure that a qualified technician checks efficiency of the ducting or other devices.

Never clean the appliance or connected parts with easily flammable substances.

Never leave containers or flammable substances in the same environment as the appliance.

• **Attenzione:** the use of components involving use of electrical power requires some fundamental rules to be observed:

- do not touch the appliance with wet or moist parts of the body; do not touch when bare-foot;
- do not pull electric cables;
- the appliance power cable must not be replaced by the user;
- in the event of damage to the cable, switch off the appliance and contact exclusively qualified staff for replacement;
- if the appliance is not to be used for a certain period, disconnect the main power switch.

INSTALLER

USER

MAINTENANCE TECHNICIAN

2.4 CONTROL PANEL.

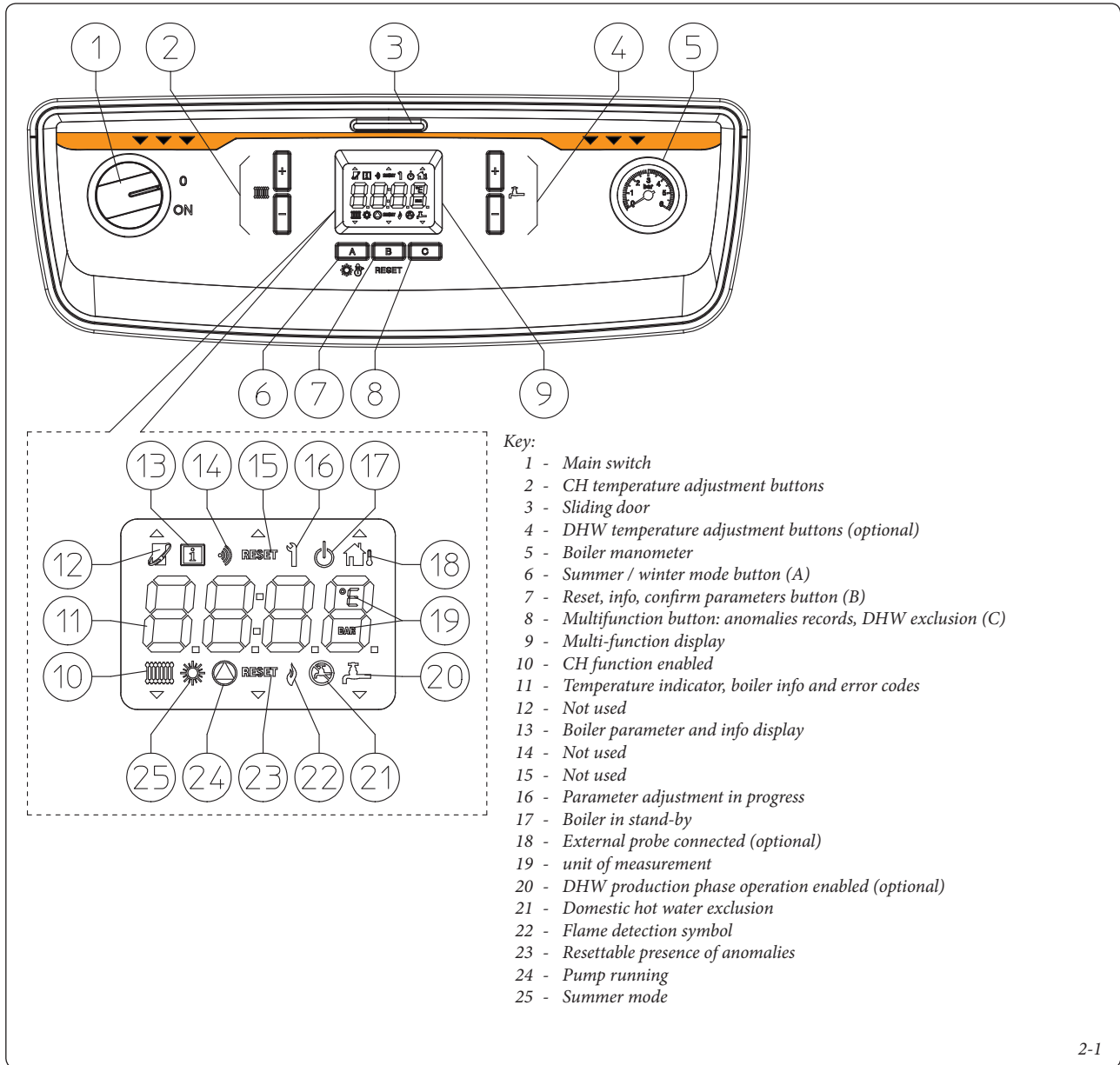

2-1

2.5 USING THE BOILER.

Before ignition, make sure that the system is full of water, checking that the manometer (5) indicates a base value at which the system has been designed and calculated and however not less than 0.5 bar.

- Open the gas cock upstream from the boiler.
- Turn the main switch, and the boiler run a self-diagnosis. It will then go back to the status it was in prior to being switched off.

- **“A” operating mode button** (☀️): with the boiler on, press the button (A) repeatedly to change the operating mode. It will switch from summer mode (☀️) (only DHW heating, when the optional kit is installed) to winter mode (room and DHW heating), alternately.

With the boiler on but not running, the screen will display the flow probe temperature reading.

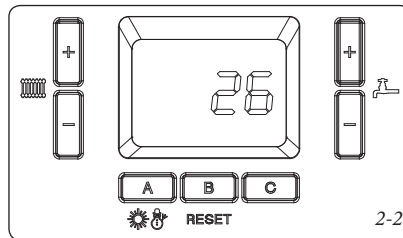

If requested, the boiler switches on and the relative symbols will be displayed, indicating the flow probe temperature reading.

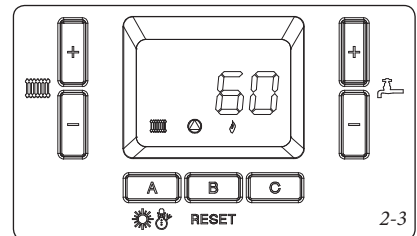

- **Summer** (☀️): in this mode the boiler only operates for domestic hot water heating.

By pressing the + or - buttons just once (4 fig. 2-1) it is possible to read the temperature setting. By pressing them again you can change the settings as needed. You will need to press "B" to save the new value. The temperature reading will flash during adjustment. If a certain amount of time lapses without saving the value, the boiler will exit setting mode and maintain the previous setting.

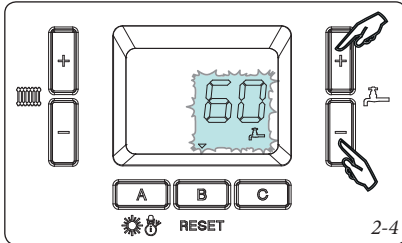

- **Winter**: in this mode the boiler functions both for heating domestic hot water and heating the environment.

By pressing the + or - (2 fig. 2-1) buttons once, you can view the temperature setting. By pressing them again you can change the setting as needed. You will need to press "B" to save the new value. The temperature reading will flash during adjustment. If a certain amount of time lapses without saving the value, the boiler will exit setting mode and maintain the previous setting.

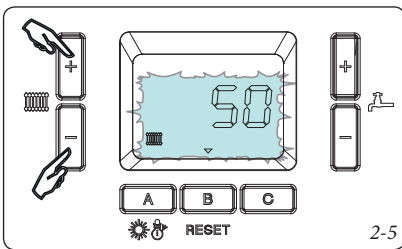

- **Stand-by mode** (⏻): by pressing buttons "A" and "C" at the same time it is possible to place the boiler in stand-by.

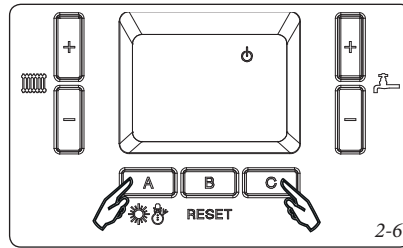

In this mode the boiler is considered powered on but not active. Accordingly, the appliance's anti-freeze function is guaranteed. To turn it back on simply press "B".

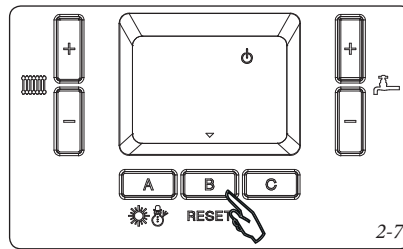

- **DHW exclusion** (🚫): with the boiler set up for DHW heating, press "C" momentarily to exclude DHW heating mode operation. To restore DHW heating, press "C" again.

- **Anomaly records**: press and hold "C" down to access the records of the last 8 anomalies that have affected the boiler (list from H i 0 to H i 7, where H i 0 is the most recent anomaly). When you are in the menu, the screen will display, in order, number "bu 0", the number and code for the anomaly.

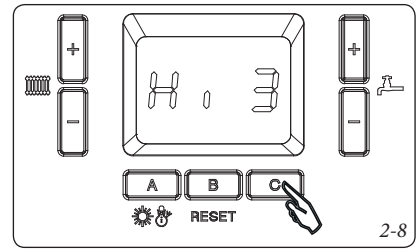

To scroll through the list, press buttons + and - (ref. 2 fig. 2-1).

To exit the menu, press and hold "C" down again.

**Attention:** anomalies with the "FE" code are not saved in the anomaly records.

## 2.6 TROUBLESHOOTING.

The boiler will let you know of any anomalies by the flashing screen and code. There are different types of codes that can be divided up as follows:

- "0Axx" for resettable anomalies (fig. 2-9).  
(Before resetting the anomaly you will need to wait for the boiler to finish its post-ventilation function, which lasts approximately 60 seconds).

- "0Exx" and "FExx" for non-resettable anomalies.

The "xx" suffix stands for the error code described in the following tables.

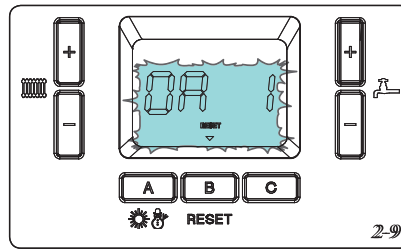

Error Code	Anomaly signalled	Cause	Solution
0A1	No ignition block	In the event of request of room central heating or domestic hot water production, the boiler does not switch on within the preset time. Upon appliance commissioning or after extended downtime, it may be necessary to eliminate the block.	Press the Reset button (1)
0A2	Parasite flame block	This occurs during the power-on phase in the event of a leak on the detection circuit or anomaly in the flame control unit.	Press the Reset button (1)
0A3	Overheating block	During normal operation, if a fault causes excessive overheating internally, the boiler goes into overheating block.	Press the Reset button (1)
0A5	Fan signal anomaly	This occurs if the fan speed is incorrect.	Press the Reset button (1)
0A7	Flue temperature anomaly	If the boiler fails, the flue circuit will provide an excessively high temperature reading and the boiler will switch off.	Press the Reset button (1)
0A9	Gas valve electric circuit anomaly	The board detects an anomaly in the gas valve circuit	Press the Reset button (1)
0A13	Maximum N° of reset	Number of allowed resets that have already performed.	<b>Attention:</b> it is possible to reset the anomaly up to 5 consecutive times within 15 minutes. By switching the appliance on and off the 5 attempts are re-acquired.
0A15	Flow and return NTC probe temperature detection incorrect (in stand-by)	With the boiler in stand-by, the board detects an anomalous difference between the NTC probe flow and return temperatures. The error may be caused by a failure in one of the two probes	Press the Reset button (1)
0A16	Poor thermal flow NTC probe contact	During boiler operation the board does not detect a change in the flow NTC probe temperature. The error may be caused by a poor thermal probe contact or a system with excessive thermal inertia.	Press the Reset button (1)
0A17	Poor thermal return NTC probe contact	During boiler operation the board does not detect a change in the return NTC probe temperature. The error may be caused by a poor thermal probe contact or a system with excessive thermal inertia.	Press the Reset button (1)
0A18	Flow and return NTC probe temperature detection incorrect	If the board detects a sudden drop in temperature on one of the two NTC probes (flow and return), it will report an anomaly. This may be caused by the failure of one of the two probes	Press the Reset button (1)
0A30	Flow NTC probe in short circuit	The board detects a short circuit on the flow NTC probe.	Press the Reset button (1)
0A31	Flow NTC probe outside the operating range	The board detects an open contact on the flow NTC probe.	Press the Reset button (1)
0A37	Insufficient system flow	If the system flow is too low for a certain period, the boiler will detect the anomaly.	Check the flow meter, check the system. Press the Reset button (1)
0A43	Return NTC probe in short circuit	The board detects a short circuit on the return NTC probe	Press the Reset button (1)
0A44	Return NTC probe outside the operating range	The board detects an open contact on the return NTC probe.	Press the Reset button (1)
0A80	Flow and return NTC probe connection error	If the electrical connection between the two NTC probes is switched around, the board will detect the anomaly (it may be necessary to wait 3 minutes for the error to be detected).	Press the Reset button (1)

(1) If the block or anomaly persists, contact an authorised company (e.g. Immergas Technical After-Sales Service).

Error Code	Anomaly signalled	Cause	Solution
0E2	Parasite flame block	This occurs during the power-on phase in the event of a leak on the detection circuit or anomaly in the flame control unit.	(2) (1)
0E8	Flame circuit anomaly	During the ignition phase an anomaly was detected on the electronic flame control circuit and the boiler switches off.	(2) (1)
0E21	P.C.B. error	An error is detected on the P.C.B. and the boiler does not start up	(2) (1)
0E25	P.C.B. error	An error is detected on the P.C.B. and the boiler does not start up	(2) (1)
0E32	DHW NTC probe in short circuit	The board detects a short circuit on the DHW NTC probe	(2) (1)
0E33	DHW NTC probe outside the operating range	The board detects an open contact on the DHW NTC probe.	(2) (1)
0E34	Low power supply voltage	This occurs when the power supply voltage is lower than the allowed limits for the correct boiler operation.	(2) (1)
0E37	Insufficient system pressure or flow	If the system pressure or input is too low the boiler switches off.	Check on the boiler pressure gauge (1) that the system pressure is between 1÷1.2 bar and restore the correct pressure if necessary. Make sure that the boiler input is suitable for the installed circuit. (2) (1)
0E45	Flue NTC probe in short circuit	The board detects a short circuit on the flue NTC probe.	(2) (1)
0E46	Flue NTC probe outside the operating range	The board detects an open contact on the flue NTC probe.	(2) (1)
0E81	Flow and return NTC probe temperature detection incorrect (in stand-by)	With the boiler in stand-by, the board detects an anomalous difference between the NTC probe flow and return temperatures. The error may be caused by a failure in one of the two probes	(2) (1)
<p>(1) If the block or anomaly persists, contact an authorised company (e.g. Immergas Technical After-Sales Service).  (2) If normal operating conditions are restored, the boiler re-starts without having to be reset.</p>			

Error Code	Anomaly signalled	Cause	Solution
FE90	The P.C.B. is not compatible	An incompatibility between the boiler's P.C.B. and the display board has been detected.	Check the P.C.B.s. (2) (1)
FE94	Display board anomaly	An error is detected on the display's P.C.B..	(2) (1)
FE95	Flow NTC probe short-circuited or out of range	The board detects an incorrect value on the flow NTC probe.	(2) (1)
FE96	External probe anomaly	An anomaly is detected on the external probe.	Check the boiler configuration, check the external probe (2) (1)
FE97	Configuration error	P.C.B. configuration error. This may happen when the P.C.B. is changed.	Check the configuration parameters (when the P.C.B. is reconfigured, press and hold the “.” (fig. 2-1 ref. 2) button down until "AUTO" appears, then press "RESET" until “bu 1” appears). (2) (1)
FE99	Internal communication anomaly	A communication error has been detected between the display board and the boiler's P.C.B..	(2) (1)
<p>(1) If the block or anomaly persists, contact an authorised company (e.g. Immergas Technical After-Sales Service).  (2) If normal operating conditions are restored, the boiler re-starts without having to be reset.</p>			

### 2.7 INFO MENU.

Press and hold down "B" to access the info menu containing all of the various information relative to boiler operation.

Once you are inside the menu, you will momentarily see the parameter number followed by the value.

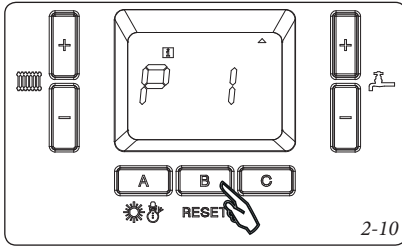

To scroll through the various parameters, press buttons + and - (ref. 2 fig. 2-1).

To exit the menu, press and hold "B" down again.

While the parameter value is being displayed it is possible to momentarily see the relative code again by pressing button "A". The viewable parameters are listed in the following tables.

### 2.8 BOILER SHUTDOWN.

Disconnect the main switch (1) taking it to the "0" position and close the gas cock upstream from the appliance.

Never leave the boiler switched on if left unused for prolonged periods.

### 2.9 RESTORING CENTRAL HEATING SYSTEM PRESSURE.

Periodically check the system water pressure. The boiler manometer should indicate a value not below 0.5 bar.

*If the pressure is below 0.5 bar (with cold system) the water inside the system must be restored.*

**N.B.:** close the valve after the operation.

If pressure values reach around 4 bar the safety valve may be activated.

In this case contact a professional technician for assistance.

In the event of frequent pressure drops, contact qualified staff for assistance to eliminate possible system leakage.

### 2.10 SYSTEM DRAINAGE.

To drain the boiler, use the appropriate system drain fitting.

Before draining, ensure that the system filling valve is closed.

### 2.11 ANTI-FREEZE PROTECTION.

The boiler is supplied with an antifreeze function as standard that activates the function of the pump and the burner when the system water temperature in the boiler falls below 5°C. The antifreeze function is guaranteed if the boiler is fully operative, if it is not in "block" status and is electrically powered with the main switch on "ON". To avoid keeping the system switched on in case of a prolonged absence, the system must be drained completely or antifreeze substances must be added to the heating system water. In systems that are drained frequently, filling must be carried out with suitably treated water to eliminate hardness that can cause lime-scale.

### 2.12 CASE CLEANING.

Use damp cloths and neutral detergent to clean the boiler casing. Never use abrasive or powder detergents.

### 2.13 DECOMMISSIONING.

In the event of permanent shutdown of the boiler, contact professional staff for the procedures and ensure that the electrical, water and gas supply lines are shut off and disconnected.

Info menu		
Menu item	Description	Unit of measurement
P01	Flame current	µA
P02	Flow NTC probe temperature reading	°C / °F
P03	Return NTC probe temperature reading	°C / °F
P04	DHW NTC probe temperature reading (if installed)	°C / °F
P05	System water flow	l/minute
P06	Operating power	%
P07	Fan speed requested by the system	RPM / 50
P08	Current fan speed	RPM / 50
P09	Flue NTC probe temperature reading	°C / °F
P10	Not used	-
P11	External probe temperature reading (if installed)	°C / °F
P12	Not used	-
P13	Flow temperature requested by the system in heating	°C / °F
P14	Flow temperature requested by the system in DHW	°C / °F
P15	Not used	-
P16	Not used	-
P17	Not used	-





3.2 WIRING DIAGRAM.

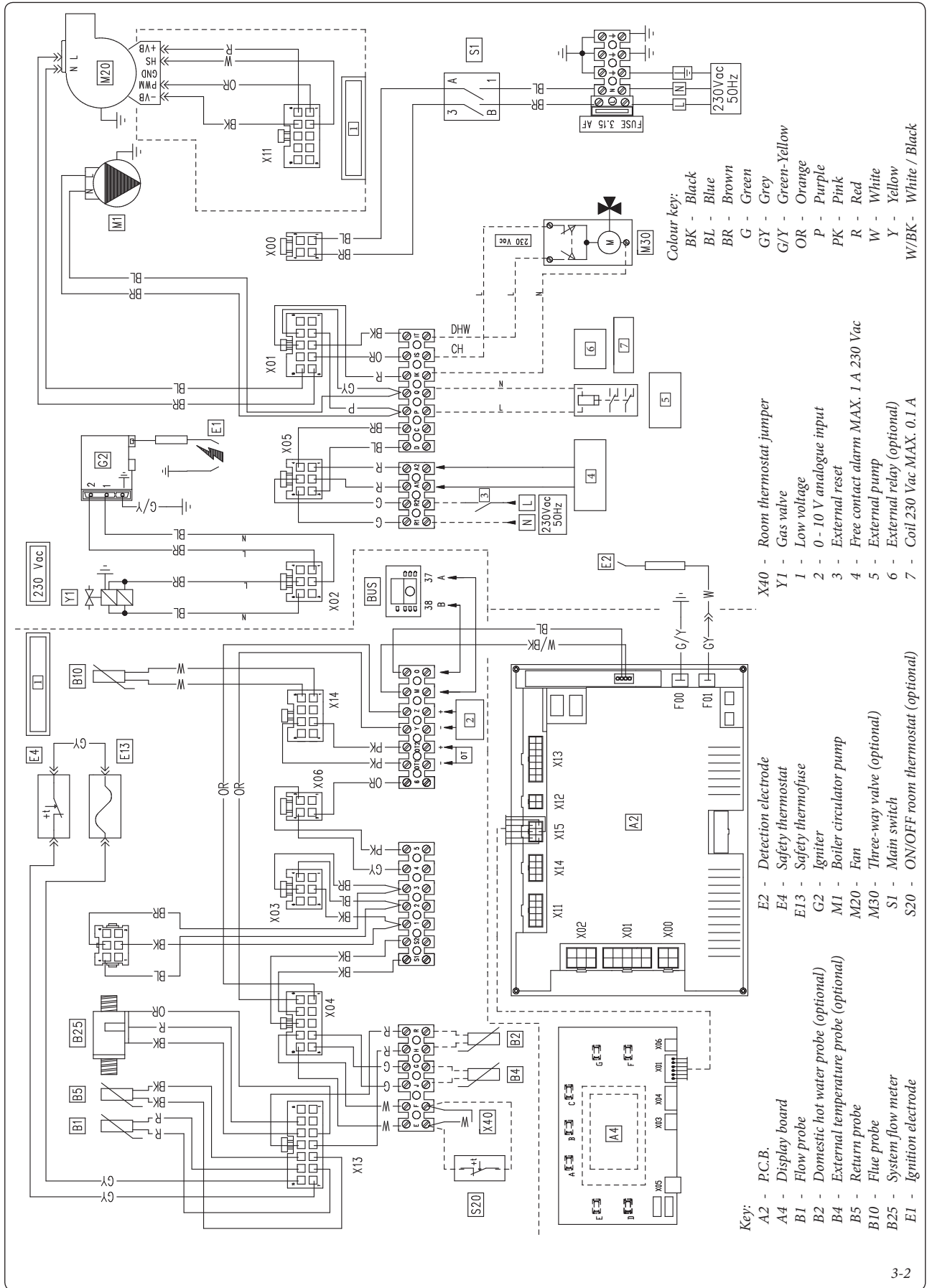

The jumper X40 must be eliminated whenever the room thermostat or cascade regulator are connected.

For safety reasons the P.C.B. envisions a fuse that cannot be restored in series with the electric power supply of the gas valve.

### 3.3 TROUBLESHOOTING.

**N.B.:** maintenance interventions must be carried out by an authorised company (e.g. Immergas After-Sales Technical Assistance Service).

- Smell of gas. Caused by leakage from gas circuit pipelines. Check sealing efficiency of gas intake circuit.
- Repeated ignition blocks. No gas, check the presence of pressure in the network and that the gas adduction valve is open. Incorrect adjustment of the gas valve, check the correct calibration of the gas valve.
- Irregular combustion or noisiness. It may be caused by: a dirty burner, incorrect combustion parameters, intake-exhaust terminal not correctly installed. Clean the above components and ensure correct installation of the terminal, check correct setting of the gas valve (Off-Set setting) and correct percentage of CO<sub>2</sub> in flue gases.
- The over temperature safety thermostat, the flow probe or the return probe are triggered frequently. It can depend on the lack of water in the boiler, little water circulation in the system or blocked pump. Check on the manometer that the system pressure is within established limits. Check that the radiator valves are not closed and also the functionality of the pump.

Also check the integrity of the thermofuse, and if it has been triggered it will be necessary to check the integrity of the module and the flue circuit.

- Drain trap clogged. This may be caused by dirt or combustion products deposited inside. Check, by means of the condensate drain cap, that there are no residues of material blocking the flow of condensate.
- Heat exchanger clogged. This may be caused by the trap being blocked. Check, by means of the condensate drain cap, that there are no residues of material blocking the flow of condensate.

- Noise due to air in the system. Check opening of the special air vent valve cap (Fig. 1-25 Ref. 23). Check that system filling and air bleeding has been performed according to the requirements.
- Noise due to air inside the condensation module. Use the manual air vent valve (Fig. 1-25 Ref. 13) to eliminate any air present in the condensation module. When the operation has been performed, close the manual vent valve.
- No DHW is produced. The boiler is equipped with a function that automatically recognises when there is an optional DHW probe, and an anomaly is reported if there is a failure affecting the DHW NTC probe. If there is a power outage, or if the boiler is switched off and back on again during the failure, it will not be possible to detect said failure, but it will, however, be recorded in the errors anomaly records.

### 3.4 PROGRAMMING THE BOILER P.C.B.

The boiler is prepared for possible programming of several operation parameters. By modifying these parameters as described below, the boiler can be adapted according to specific needs.

- Access programming by pressing and holding down buttons "B" and "C".

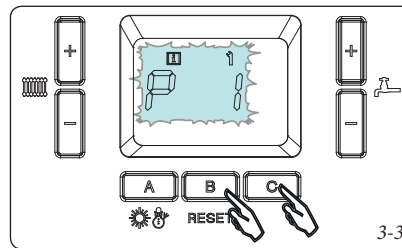

- Scroll through the parameters by pressing the + and - heating adjustment buttons,

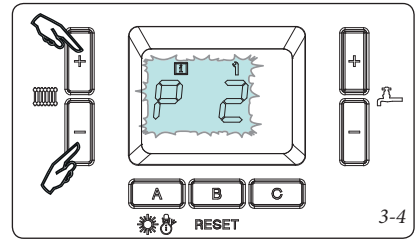

- Change the parameter by pressing the + and - DHW adjustment buttons.

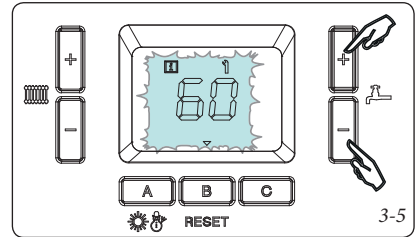

- Save the parameters by switching from one parameter to the next or by pressing "B". If you wait approximately 2 minutes the boiler will exit the programming menu without saving any changes, and will run a self-diagnosis of the parameters by displaying "PARA" followed by "Auto".

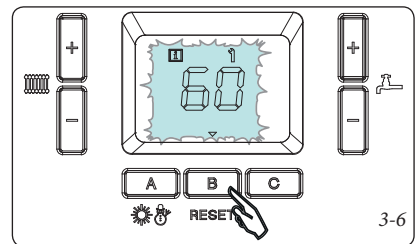

- Exit the programming mode by pressing and holding down buttons "B" and "C", the boiler will then run a self-diagnosis of the parameters by displaying "PARA" followed by "Auto".
- While the value of a parameter is being displayed, press "B" quickly to see the code again.

Programming menu				
Menu item	Description	Adjustment range	Default value	
P01	Set Risc (CH Set)	This defines the boiler's flow temperature during heating	20 ÷ P02 °C	85
P02	Set risc Max (Max CH Set)	This defines the maximum settable flow temperature during heating	20 ÷ 95 °C	85
P03	Isteresi riscaldamento (Heating Hysteresis)	This defines the power-off hysteresis during the heating phase	2 ÷ 10 °C	5
P04	Anti cicli riscaldamento (Anti-cycle CH)	This is used to set a waiting time to avoid the boiler from switching on multiple times and frequently during CH mode	0 ÷ 15 minutes	3 minutes
P05	Tempo min risc (CH min time)	This is the amount of time that the boiler needs to stabilise, when the burner runs at minimum power for the set amount of time	3 ÷ 10 minutes	3 minutes
P06	Rampa riscaldamento (CH ramp)	The amount of time that the boiler takes to reach the required temperature, number of degrees per minute (0 means no ramp)	0 ÷ 60 °C/minute	4 °C/minute
P07	Post circolazione riscaldamento (CH post-circulation)	The amount of CH post circulation once the CH phase is finished	1 ÷ 30 minutes	3 minutes

Programming menu				
Menu item	Description	Adjustment range	Default value	
P08	Pot risc max disponibile (Available max heat out)	This defines the maximum power percentage to be used during the set CH phase	P09 ÷ 100%	100%
P09	Pot risc min disponibile (Available max heat out)	This defines the minimum power percentage to be used during the set CH phase	0 ÷ P08%	0%
P10	Minimum system flow rate	This defines the minimum system flow rate required to power-on the boiler <b>Attention:</b> do not change this parameter	5 ÷ 47 l/minutes	14 l/minutes
P11	Anti umidità elettrodi (Electrodes anti-humidity)	This defines fan speed and operating mode, to avoid humidity inside the condensing module, which could otherwise cause the electrodes to malfunction (0 = disabled function, recommended value = 40)	P26 ÷ 120 RPM x 50	0
P12	-	Not used		20
P13	Boiler power	This defines the boiler power (this parameter has no effect on boiler operation)	0 ÷ 255 kW	35 kW = 35 55 kW = 50
P14	External probe curve	This is used to select the external probe operating curve (optional) (0 = disabled probe)	0 ÷ 10	0
P15	External probe offset	This defines the CH offset in relation to the selected external probe curve	20 ÷ 70 °C	30 °C
P16	Set San (DHW set)	This defines the DHW temperature	20 ÷ 65 °C	65 °C
P17	-	Not used		
P18	Isteresi sanitario (DHW hysteresis)	This defines the DHW power-on hysteresis during CH	2 ÷ 10 °C	5 °C
P19	Post circolazione sanitario (DHW post-circulation)	This is the post circulation time during DHW once DHW production is finished	0 ÷ 180 seconds	60 seconds
P20	Pot san max disponibile (Available max DHW pow)	This defines the maximum power percentage to be used during the set DHW phase	P21 ÷ 100 %	50 %
P21	Pot san min disponibile (Available max DHW pow)	This defines the minimum power percentage to be used during the set DHW phase	0 ÷ P20 %	0 %
P22	DHW flow temperature with thermostat	In combination with a storage tank and a separate thermostat, this defines the flow temperature during DHW operation	35 ÷ 90 °C	80 °C
P23	Modulazione sanitario (DHW modulation)	Summed with the "Set San" (P16) parameter, this defines the flow temperature set that the boiler has to modulate the power on during DHW	5 ÷ 30 °C	15 °C
P24	Incremento off sanitario (DHW off increment)	This defines the time that the boiler allows the burner to switch off during DHW, by an increment of 5 °C on top of the flow temperature	0 ÷ 255 seconds	60 seconds
P25	Velocità Max ventilatore (Min fan Speed)	This defines the max fan speed and therefore the maximum relative boiler operating power	P26 ÷ 255 RPM x 50	35 kW Met. 101 35 kW LPG 98 55 kW Met. 131 55 kW LPG 129
P26	Velocità Min ventilatore (Min fan Speed)	This defines the min fan speed and therefore the minimum relative boiler operating power	0 ÷ P25 RPM x 50	35 kW Met. 20 35 kW LPG 20 55 kW Met. 22 55 kW LPG 21
P27	Velocità min circolatore (Min pump speed)	Not used on this boiler model	- - -	75 %
P28	Velocità circolatore in accensione bruciatore (Pump speed during burner ignition)	Not used on this boiler model	- - -	75 %
P29	Configurazione sanitario (DHW configuration)	This is used to select the DHW operating mode, choosing between NTC probe or on/off thermostat	1 = NTC probe 17 = on/off thermostat	1
P30	Velocità in accensione ventilatore (Speed during fan power-on)	This defines the fan speed during burner ignition <b>Attention:</b> do not change this parameter	0 ÷ 114 RPM x 50 (range limited by parameters P25 and P26)	46
P31	Unit of measurement	This defines the unit of measure on the display, whether metric or Imperial	0 ÷ 127 = °C - kW 128 ÷ 256 = °F - kBtu/h	0
P32	-	Not used		0
P33	-	Not used		5
P34	-	Not used		15
P35	-	Not used		60
P36	Temperature adjustment calculation time	This defines the time required to calculate the boiler temperature <b>Attention:</b> do not change this parameter	1 ÷ 10 seconds	3 seconds

### 3.5 CONVERTING THE BOILER TO OTHER TYPES OF GAS.

If the boiler has to be converted to a different gas type to that specified on the data plate, request the relative conversion kit for quick and easy conversion.

The gas conversion operation must be carried out by an authorised company (e.g. Immergas After-Sales Technical Assistance Service).

To convert to another type of gas the following operations are required:

- disconnect the appliance;
- Change the sleeve with Venturi (det. 4 fig. 1-25);
- change the gas nozzle (det. 3 fig. 1-25);
- re-power the appliance;
- regulate the maximum heat output by varying the number of fan revs. (parameter P25 "Max number of fan revs in CH mode") according to par. 3.17;
- regulate the minimum heat output by varying the number of fan revs. (parameter P26 "Min number of fan revs in CH mode") according to par. 3.17;
- activate the chimney sweep function;
- check the CO<sub>2</sub> value on the table in par. 3.18, especially:
  - check the CO<sub>2</sub> value in the flue with chimney sweep at 0%;
  - check the CO<sub>2</sub> value in the flue with chimney sweep at 100%;
- exit the chimney sweep function;
- seal the gas flow rate regulation devices (if settings are modified);
- after completing the conversion, apply the sticker, contained in the conversion kit, near the data-plate. Using an indelible marker pen, cancel the data relative to the old type of gas.

These adjustments must be made with reference to the type of gas used.

### 3.6 CHECKS FOLLOWING CONVERSION TO ANOTHER TYPE OF GAS.

After making sure that transformation was carried out with the Venturi and a nozzle of suitable diameter for the type of gas used and the calibration has been performed at the correct num. of revs, check that:

- the burner flame is not too high and that it is stable (does not detach from burner);
- there are no leaks from the gas circuit.

**N.B.:** all boiler adjustment operations must be carried out by a qualified technician (e.g. Immergas After-Sales Assistance).

### 3.7 HEAT OUTPUT CHECK.

The boiler heat output is correlated to the length of the air intake and flue exhaust pipes. This decreases slightly with the increase of pipe length.

### 3.8 ADJUSTMENT OF THE AIR-GAS RATIO.

**Calibration of minimum CO<sub>2</sub>**  
Turn the boiler on and start the chimney sweep functions at minimum output (0%). To have an exact value of CO<sub>2</sub> the technician must insert the sampling probe to the bottom of the sample point, then check that the CO<sub>2</sub> value is that specified in the table in par. 3.18, on the contrary, regulate the screws (3 fig. 3-8) (Off-Set regulator). To increase the CO<sub>2</sub> value, turn the adjustment screw (3) in a clockwise direction and vice versa to decrease it.

**Calibration of maximum CO<sub>2</sub>**  
When you finish the minimum CO<sub>2</sub> adjustment, turn the boiler on and start the chimney sweep function at the maximum output (100%). To have an exact value of CO<sub>2</sub> the technician must insert the sampling probe to the bottom of the sample point, then check that the CO<sub>2</sub> value is that specified in the table in par. 3.18, otherwise, adjust the screw (12 fig. 3-8) (gas flow rate regulator). To increase the CO<sub>2</sub> value, turn the adjustment screw (12) in an anti-clockwise direction and vice versa to decrease it.

At every adjustment variation on the screw (12) it is necessary to wait for the boiler to stabilise itself at the value set (about 30 sec.).

### 3.9 CH OUTPUT ADJUSTMENT.

If it is necessary to change the CH output, you will need to adjust the "P08" maximum CH output and "P09" minimum CH output parameters. To check the regulated heat output value, compare the no. of fan revs with that in the table (par. 3.17).

### 3.10 OUTPUT ADJUSTMENT DURING DHW (ONLY IN COMBINATION WITH AN OPTIONAL EXTERNAL STORAGE TANK).

If it is necessary to change the DHW output, you will need to adjust the "P20" maximum DHW output and "P21" minimum DHW output parameters.

To check the regulated heat output value, compare the no. of fan revs with that in the table (par. 3.17).

### 3.11 "CHIMNEY SWEEP" FUNCTION.

This function allows the technician to check the combustion parameters. Boiler operation in chimney sweep function can be adjusted to an output between 0% and 100%.

To enable the function press and hold down "A"

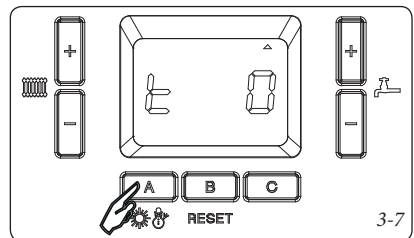

The output is adjusted from the + and - DHW adjustment buttons at a range between 0 and 100%, while using the + and - buttons for CH adjustment, the percentage changes by 1% each time they are pressed.

In this state all adjustments are excluded and only the temperature safety thermostat and the limit thermostat remain active. When the checks are finished disable the function by pressing and holding down button "A".

If you enable the function when there is no active request, you will need to wait approximately 30" to reach the set output. If you enable the function when there is an active request, you will need to wait approximately 3 minutes to reach the set output.

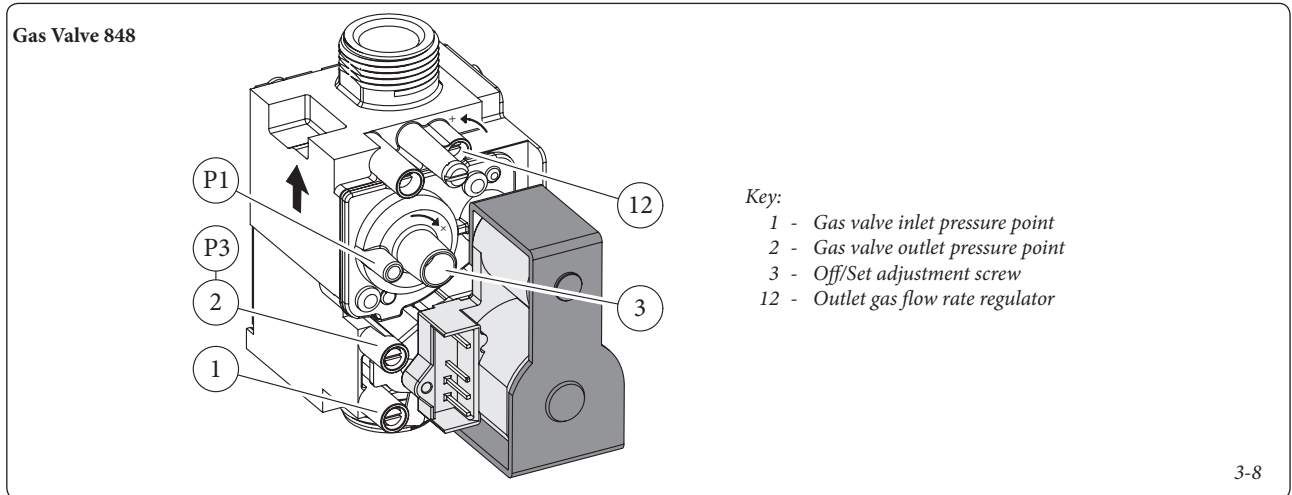

### 3.12 3-WAY PUMP ANTI-BLOCK FUNCTION (OPTIONAL).

The boiler has a function that starts the pump and 3-way valve at least once every 24 hours for the duration of 20 seconds in order to reduce the risk of the pump becoming blocked due to prolonged inactivity.

### 3.13 RADIATORS ANTI-FREEZE FUNCTION.

The boiler has a function that makes the pump start when the system flow water reaches 8 °C. If the system flow water is at a temperature below 5 °C, the boiler starts to operate until it reaches approximately 16 °C.

### 3.14 ANTI-HUMIDITY ELECTRODE FUNCTION.

With cascade installations combined with their relative flue manifold kits with flue adjusting devices, humidity may develop on the electrodes, causing them to fail. Avoid the formation of humidity by enabling this function (by setting a value other than 0), which turns the fan on at the speed set in parameter "P11" (5 minutes on and 5 minutes off). The function is active when the burner is off and the flow NTC probe temperature reading is greater than 35°C. The function is disabled when the temperature drops below 30 °C.

### 3.15 YEARLY APPLIANCE CHECK AND MAINTENANCE.

The following checks and maintenance should be performed at least once a year.

- Clean the flue side of the heat exchanger.
  - Clean the main burner.
  - If deposits are detected in the combustion chamber one must remove them and clean the exchanger coils using nylon or sorghum brushes; it is forbidden to use brushes made of metal or other materials that may damage the combustion chamber itself.
  - Check the integrity of the insulating panels inside the combustion chamber and if damaged replace them.
  - Visually check for water leaks or oxidation from/on fittings and traces of condensate residues inside the sealed chamber.
  - Check contents of the condensate drain trap.
  - Via the condensate drain cap check that there are no residues of material that clog condensate passage; also check that the entire condensate drainage circuit is clear and efficient.
- In the event of obstructions (dirt, sediment, etc.) with consequent leakage of condensate in the combustion chamber, one must replace the insulating panels.
- Check that the burner seal gaskets and the lid are intact and perfectly efficient, otherwise replace them. In any case the gaskets must be replaced at least every two years, regardless of their state of wear.
  - Check that the burner is intact, that it has no deformations or cuts and that it is properly fixed to the combustion chamber lid; otherwise it must be replaced.
  - Visually check that the water safety drain valve is not clogged.
  - Check that the system static pressure (with system cold and after refilling the system by means of the filler cock) is not below 0.5 bar.

- Visually check that the safety and control devices have not been tampered with and/or shorted, in particular:

- temperature safety thermostat;
- Check the condition and integrity of the electrical system and in particular:
  - electrical power cables must be inside the fairleads;
  - there must be no traces of blackening or burning.
- Check ignition and operation.
- Check correct calibration of the burner in central heating phase.
- Check the operation of the appliance control and adjustment devices and in particular:
  - intervention of the main electrical switch on the boiler;
  - system regulation probes intervention;
- Check sealing efficiency of the gas circuit and the internal system.
- Check the intervention of the device against no gas ionisation flame control. The relative intervention time must be less than 10 seconds.

**N.B.:** in addition to yearly maintenance, one must also check the thermal system, with frequency and procedures that comply with the indications of the technical regulations in force.



### 3.16 CASING REMOVAL.

To facilitate boiler maintenance the casing can be completely removed as follows:

- take the two screws out (3) from the bottom of the front (2);
- take the front down (2) by gripping its bottom handle, then pulling it towards yourself to detach it from the central hooks, and then slide it downwards;
- take the two clamping screws out (4) from the control panel, with their rings (5);
- press the two side hooks (7) and tilt the control panel (6);
- remove the lower grid (8) by loosening the 4 screws (9);
- at this point, if necessary, you can take down the protective cover (10) and side panels (12);
- take the cover down (10) by removing the relative screws (11);
- take down the two side panels (12) by removing the front screws (13) and unhooking the panels (ref. A fig. 3-10).

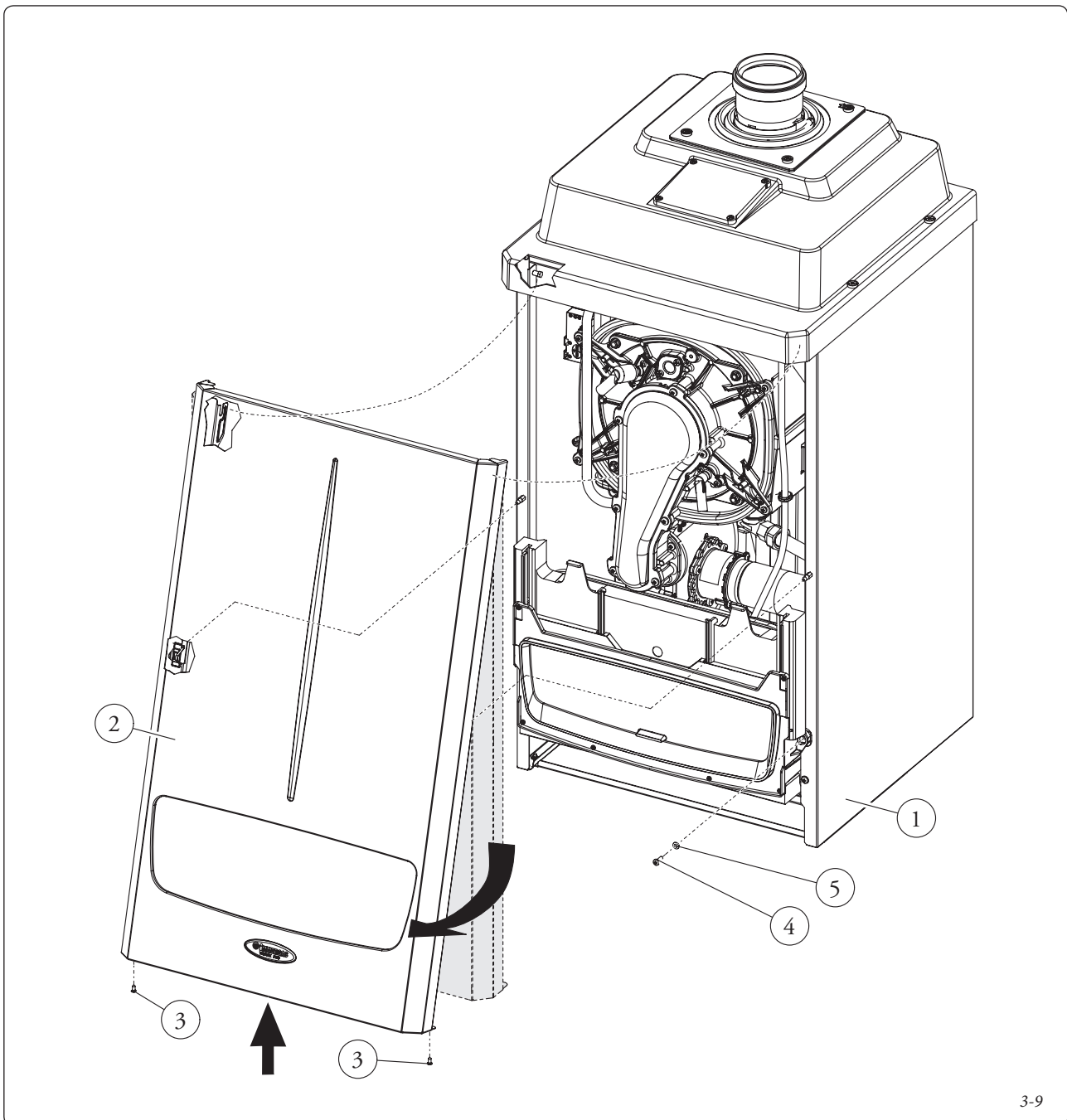

3-9

INSTALLER

USER

MAINTENANCE TECHNICIAN

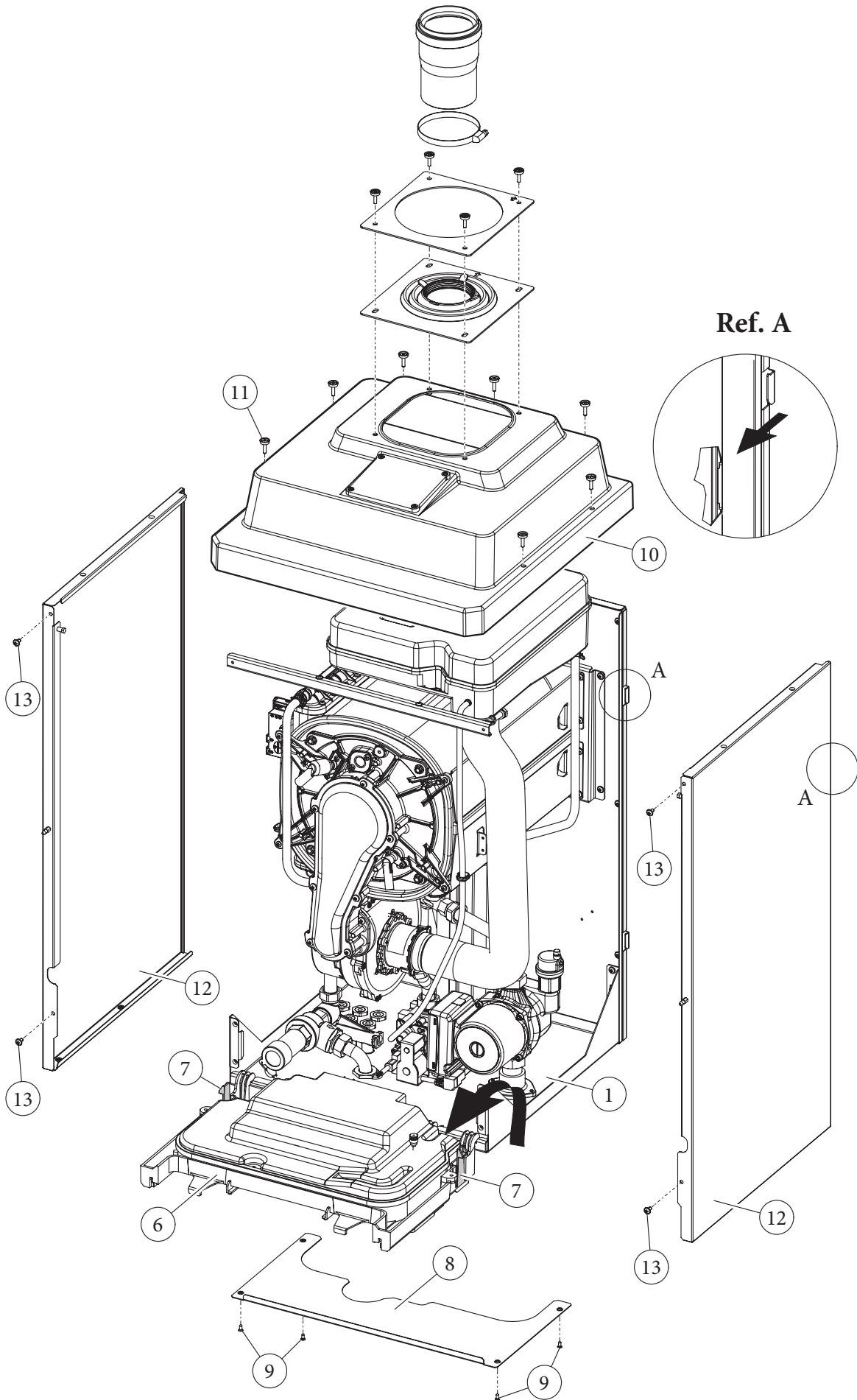

3-10

### 3.17 VARIABLE HEAT OUTPUT.

#### Victrix Pro 35 1 I.

		METHANE (G20)		PROPANE (G31)	
HEAT OUTPUT	HEAT OUTPUT	BURNER GAS FLOW RATE	REVS FAN	BURNER GAS FLOW RATE	REVS FAN
(kW)	(kcal/h)	(m <sup>3</sup> /h)	(n°)	(kg/h)	(n°)
34.0	29240	3.70	5050	2.71	4900
33.0	28380	3.58	4920	2.63	4770
32.0	27520	3.47	4780	2.54	4640
31.0	26660	3.35	4650	2.46	4510
30.0	25800	3.24	4520	2.38	4380
29.0	24940	3.13	4400	2.30	4260
28.0	24080	3.02	4270	2.22	4130
27.0	23220	2.92	4140	2.14	4010
26.0	22360	2.81	4010	2.06	3880
25.0	21500	2.71	3890	1.99	3760
24.0	20640	2.60	3760	1.91	3640
23.0	19780	2.50	3640	1.83	3520
22.0	18920	2.39	3510	1.76	3400
21.0	18060	2.29	3390	1.68	3280
20.0	17200	2.19	3260	1.61	3150
19.0	16340	2.09	3130	1.53	3030
18.0	15480	1.98	3010	1.46	2910
17.0	14620	1.88	2880	1.38	2790
16.0	13760	1.78	2750	1.31	2670
15.0	12900	1.68	2630	1.23	2540
14.0	12040	1.57	2500	1.15	2420
13.0	11180	1.47	2360	1.08	2290
12.0	10320	1.37	2230	1.00	2170
11.0	9460	1.26	2100	0.92	2040
10.0	8600	1.15	1960	0.85	1910
9.0	7740	1.05	1820	0.77	1780
8.0	6880	0.94	1680	0.69	1650
7.0	6020	0.83	1540	0.61	1510
6.0	5160	0.72	1390	0.53	1370
5.0	4300	0.60	1250	0.44	1230
4.0	3440	0.49	1090	0.36	1090
3.4	2924	0.42	1000	0.31	1000

#### N.B.

- The power data provided in the table is obtained with 0.5 m long intake/exhaust pipe.
- Gas flow rates refer to heating output below a temperature of 15°C and pressure of 1013 mbar.
- Burner pressure values refer to use of gas at 15°C.
- The number of revs for the fan on the display is expressed in revs / 50 (Ex.: 1000 revs = 20).

INSTALLER

USER

MAINTENANCE TECHNICIAN

Victrix Pro 55 1 I.

INSTALLER

USER

MAINTENANCE TECHNICIAN

		METHANE (G20)		PROPANE (G31)	
HEAT OUTPUT	HEAT OUTPUT	BURNER GAS FLOW RATE	REVS FAN	BURNER GAS FLOW RATE	REVS FAN
(kW)	(kcal/h)	(m³/h)	(n°)	(kg/h)	(n°)
49.9	42914	5.43	6550	3.98	6450
49.0	42140	5.32	6430	3.91	6330
47.0	40420	5.09	6170	3.74	6060
45.0	38700	4.87	5910	3.57	5810
43.0	36980	4.64	5660	3.41	5550
41.0	35260	4.42	5410	3.25	5300
39.0	33540	4.21	5160	3.09	5050
37.0	31820	3.99	4910	2.93	4810
35.0	30100	3.78	4670	2.77	4570
33.0	28380	3.57	4430	2.62	4330
31.0	26660	3.35	4200	2.46	4090
29.0	24940	3.14	3960	2.31	3860
27.0	23220	2.94	3720	2.16	3620
25.0	21500	2.73	3490	2.00	3390
23.0	19780	2.52	3260	1.85	3160
21.0	18060	2.31	3020	1.69	2930
19.0	16340	2.10	2790	1.54	2700
17.0	14620	1.89	2550	1.39	2470
15.0	12900	1.68	2310	1.23	2240
13.0	11180	1.46	2080	1.07	2000
11.0	9460	1.25	1840	0.91	1770
9.0	7740	1.03	1590	0.75	1530
7.0	6020	0.81	1350	0.59	1290
5.0	4300	0.58	1100	0.43	1050

**N.B.**

- The power data provided in the table is obtained with 0.5 m long intake/exhaust pipe.
- Gas flow rates refer to heating output below a

temperature of 15°C and pressure of 1013 mbar.  
 - Burner pressure values refer to use of gas at 15°C.

- The number of revs for the fan on the display is expressed in revs / 50 (Ex.: 1000 revs = 20).

**3.18 COMBUSTION PARAMETERS.**

Victrix PRO 35			
		G20	G31
Gas nozzle diameter	mm	10.5	6.3
Supply pressure	mbar (mm c.a.)	20 (204)	37 (377)
Flue flow rate at nominal heat output	kg/h	55	56
Flue flow rate at min heat output	kg/h	6	7
CO <sub>2</sub> at Q. Nom./Min.	%	9.40 / 9.10	10.60 / 10.10
CO with 0% O <sub>2</sub> at Nom./Min. Q. Nom./Min.	ppm	84 / 1	99 / 1
NO <sub>x</sub> at 0% of O <sub>2</sub> at Q. Nom./Min.	mg/kWh	35 / 12	37 / 15
Flue temperature at nominal output	°C	48	48
Flue temperature at minimum output	°C	47	47
Victrix PRO 55			
Gas nozzle diameter	mm	8.4	6.5
Supply pressure	mbar (mm H <sub>2</sub> O)	20 (204)	37 (377)
Flue flow rate at nominal heat output	kg/h	81	82
Flue flow rate at min heat output	kg/h	9	9
CO <sub>2</sub> at Q. Nom./Min.	%	9.40 / 9.10	10.60 / 10.10
CO with 0% O <sub>2</sub> at Nom./Min. Q. Nom./Min.	ppm	157 / 1	184 / 1
NO <sub>x</sub> at 0% of O <sub>2</sub> at Q. Nom./Min.	mg/kWh	43 / 17	43 / 21
Flue temperature at nominal output	°C	52	53
Flue temperature at minimum output	°C	48	48

### 3.19 TECHNICAL DATA.

		Victrix PRO 35	Victrix PRO 55
Nominal heat input	kW (kcal/h)	34.9 (30051)	51.3 (44098)
Minimum heat input	kW (kcal/h)	3.9 (3388)	5.5 (4715)
Nominal heat output (useful)	kW (kcal/h)	34.0 (29240)	49.9 (42914)
Minimum heat output (useful)	kW (kcal/h)	3.4 (2924)	5.0 (4300)
Efficiency 80/60 Nom./Min.	%	97.3 / 86.3	97.3 / 91.2
Efficiency 50/30 Nom./Min.	%	107.0 / 94.7	106.8 / 99.7
Efficiency 40/30 Nom./Min.	%	107.3 / 100.2	107.4 / 103.5
Heat loss at casing with burner On/Off (80-60°C)	%	0.44 / 1.10	0.30 / 0.90
Heat loss at flue with burner On/Off (80-60°C)	%	0.04 / 1.60	0.03 / 1.80
Central heating circuit max. operating pressure	bar	4.4	4.4
Central heating circuit max. operating temperature	°C	90	90
Adjustable central heating temperature	°C	20 - 85	20 - 85
Head available with 1000 l/h flow rate	kPa (m H <sub>2</sub> O)	46.30 (4.72)	46.30 (4.72)
Weight of full boiler	kg	54.0	54.2
Weight of empty boiler	kg	51.2	51.4
Boiler water content	l	2.8	2.8
Electrical connection	V/Hz	230/50	230/50
Nominal absorption	A	0.90	1.0
Installed electric output	W	140	195
Pump consumption	W	98	98
Fan power consumption	W	28	73
Equipment electrical system protection	-	IPX5D	IPX5D
Functioning room max. temperature	°C	+50	+50
Functioning room min. temperature	°C	-5	-5
Functioning room min. temperature with anti-freeze kit (Optional)	°C	-15	-15
Flue gas max. temperature	°C	75	75
NO <sub>x</sub> class	-	5	5
Weighted NO <sub>x</sub>	mg/kWh	25	39
Weighted CO	mg/kWh	8	15
Type of appliance	C13 / C33 / C63 / B23p / B33 / B53p		
Category	II2H3 P		

- Flue temperature values refer to an air inlet temperature of 15°C and flow temperature of 50°C.
- The maximum sound level emitted during boiler operation is < 55dBA. The sound level value is referred to semianechoic chamber tests with boiler operating at max. heat output, with extension of flue gas exhaust system according to product standards.

INSTALLER

USER

MAINTENANCE TECHNICIAN

**3.20 KEY FOR DATA PLATE.**

Md		Cod. Md	
Sr N°	CHK	Cod. PIN	
Type			
Q <sub>nw</sub> /Q <sub>n</sub> min.	Q <sub>nw</sub> /Q <sub>n</sub> max.	P <sub>n</sub> min.	P <sub>n</sub> max.
PMS	PMW	D	TM
NO <sub>x</sub> Class			
		CONDENSING	

**N.B.:** the technical data is provided on the data plate on the boiler

	IE
Md	Model
Cod. Md	Model code
Sr N°	Serial Number
CHK	Check
Cod. PIN	PIN code
Type	appliance configuration (ref. CEN TR 1749)
Q <sub>nw</sub> min.	Minimum DHW heat input
Q <sub>n</sub> min.	CH minimum heat input
Q <sub>nw</sub> max.	DHW maximum heat input
Q <sub>n</sub> max.	CH maximum heat input
P <sub>n</sub> min.	Minimum heat output
P <sub>n</sub> max.	Maximum heat output
PMS	Maximum system pressure
PMW	Maximum domestic hot water pressure
D	Specific flow rate
TM	Maximum operating temperature
NO <sub>x</sub> Class	NO <sub>x</sub> Class
CONDENSING	Condensing boiler





