

ALTA POTENZA



Scheda
TEC
ErP

 **IMMERGAS**

ARES TEC ErP

Floor standing boiler
condensation module
multi-burner



MAIN CONTENTS

1 ARES 150-350 TEC ERP FEATURES5

2 ARES 440-900 TEC ERP FEATURES7

3 COMPONENTS AND CONSTRUCTION TECHNOLOGY8

4 ARES 150-350 TEC ERP MAIN COMPONENTS10

5 ARES 440-900 TEC ERP MAIN COMPONENTS12

6 ARES 150-350 TEC ERP MAIN DIMENSIONS.....13

7 ARES 440-900 TEC ERP MAIN DIMENSIONS.....14

8 ARES 150-350 TEC ERP HYDRAULIC AND FLUE CONNECTIONS.....15

9 ARES 440-900 TEC ERP HYDRAULIC AND FLUE CONNECTIONS.....16

10 CONNECTION TO THE FLUE AND FLUE OPTIONALS.....17

11 CHIMNEY SIZING GUIDELINE18

12 HEATING CONTROL UNIT POSITIONING VALUES19

13 CONDENSATE TREATMENT20

14 FEED WATER TREATMENT21

15 INAIL SAFETY KIT WITH CIRCULATOR AND HYDRAULIC SEPARATOR (MODELS UP TO 350 KW)22

16 INAIL SAFETY KIT WITH CIRCULATOR PUMP AND HYDRAULIC SEPARATOR (MODELS FROM 440 UP TO 900 KW)23

17 PRIMARY LOOP DIMENSIONS WITH HYDRAULIC SEPARATOR (MODELS UP TO 350 KW)24

18 PRIMARY LOOP DIMENSIONS WITH HYDRAULIC SEPARATOR (MODELS FROM 440 UP TO 900 KW)25

19 INAIL (EX ISPESEL) SAFETY KIT WITH FILTER.....26

20 HYDRAULIC SEPARATOR KIT27

21 DIAGRAM FOR SELECTING THE CIRCULATION PUMP.....28

22 INAIL SAFETY KIT AND COMPLETE HYDRAULIC SEPARATOR.....30

23 EXTERNAL COVERING KIT FOR INAIL SAFETY AND COMPLETE HYDRAULIC SEPARATOR31

24 INAIL SAFETY KIT WITH CIRCULATOR AND PLATE HEAT EXCHANGER (MODELS UP TO 350 KW).....32

25 INAIL SAFETY KIT WITH CIRCULATOR AND PLATE HEAT EXCHANGER (MODELS FROM 440 UP TO 900 KW)33

26 PRIMARY LOOP DIMENSIONS WITH PLATE HEAT EXCHANGER (MODELS UP TO 350 KW).....34

27 PRIMARY LOOP DIMENSIONS WITH PLATE HEAT EXCHANGER (MODELS FROM 440 UP TO 900 KW)35

28 INAIL SAFETY KIT AND COMPLETE PLATE HEAT EXCHANGER36

29 EXTERNAL COVER KIT FOR INAIL SAFETY AND COMPLETE PLATE HEAT EXCHANGER.....37

30 PLATE HEAT EXCHANGER TECHNICAL DATA38

31 ELECTRICAL CONNECTION AND ELECTRONIC CONTROL UNITS DESCRIPTION39

32 ARES 150-350 TEC ERP PRACTICAL WIRING DIAGRAM40

33 ARES 440-900 TEC ERP PRACTICAL WIRING DIAGRAM42

34 TECHNICAL DATA44

35 COMBUSTION FEATURES49

36 TECHNICAL PARAMETERS FOR COMBINATION BOILERS (REGULATION 813/2013)59

37 OPTIONAL62

38 CONTROL PANEL66

39 CASCADE REGULATOR KIT71

40 REMOTE MANAGEMENT74

41 EXAMPLES OF HYDRAULIC APPLICATION DIAGRAMS76



ARES TEC ErP is the new multi-burner, modular, condensation floor standing boiler offered by IMMERGAS for high power systems, ideal for new or replacing obsolete generators serving large volume buildings such as apartment blocks, industrial sheds, shopping malls, school complexes, hospitals etc....

ARES TEC ErP is not just a condensing boiler, but a block that brings together various heating elements/combustion units that are independent yet managed by a single electronic control logic. Each generator is composed of several elements (3 to 7), with modulated power from 12 to 50 kW for each element and specifically: 3 elements for mod. 150, 4 elements for mod. 200, 5 elements for mod. 250, 6 elements for mod. 300, 7 elements for mod. 350.

This unique construction feature offers a broad modulation field which reaches up to about 1:30; this enables a very high efficiency ($\eta > 93 + 2 \cdot \log P_n$) in accordance with Legislative Decree 192/05 and subsequent modifications.

The small dimensions combined with high power make ARES TEC ErP the ideal boiler to solve situations where space for the unit is reduced or difficult to reach, thanks to its excellent weight-to-power ratio.

The generator is equipped with an emergency operation function, which prevents the system from being stopped.

The management logic requires simultaneous operation of the maximum number of available heating elements, to always achieve the maximum possible performance (maximum exchange surface is in fact assured).

Despite the high power that is generated, thanks to the innovative

combustion circuit technology and the aluminium, silicon and magnesium block, operation is extremely silent (sound emission below 55 dBA).

Also approved for outdoor installation, by standard it has IPX5D electrical protection and an antifreeze protection to -15°C .

The hydraulic and gas connections are reversible right and left, while the flue exhaust can be placed on 3 sides, this enables unprecedented installation flexibility.

The "ecological" soul of ARES TEC ErP is assured by special modulating total premixing boilers with constant CO_2 irradiation that allow low NO_x emissions (the boiler belongs to the most ecological class required by European Standards - Class 6) and low flue gas-sensitive losses.

Electronic management and temperature control are fully automatic and already set for generator operation.

It is also possible to electronically manage up to 8 boilers in cascade by using an optional kit and set up the system for remote management and control.

For a modern design, a number of dedicated accessories are available for completing the unit such as:

Hydraulic kits with INAIL safety (formerly ISPEL) including hydraulic separator; or hydraulic kits with INAIL (formerly ISPEL) safety including plate heat exchanger, both designed to optimise management of the system downstream of the boiler;

Flue exhaust kit;

Acid condensate drain management kit;

Additional system area temperature control kits.

ARES 150 - 350 TEC ErP

1

ARES 150-350 TEC ErP FEATURES

Broad range of 5 condensation models for open room base central heating and high performance fan assisted (type B₂₃), with power from 150 to 350 kW, which may be installed individually or as a set (up to 8 generators).

- Single technological block: heating elements installed cast in aluminium, silicon and magnesium;
- Wide modulation field (up to about 1:30);
- Very high seasonal efficiency;
- Dimensional compactness;
- Very low noise, thanks to the advanced combustion features;
- IPX5D electrical protection rating, which can be directly installed outdoors and with temperatures to -15°C;
- Good weight and power ratio;
- Low water content, with consequent quick response time to thermal load changes;
- Single flue exhaust which can be positioned on 3 sides;
- Removable integral panelling with light grey (RAL7035) side air intake grids;
- Insulation, 50 mm thick, with non-allergenic synthetic wool around the aluminium modules;
- Stainless steel condensate collection tank with level sensor which interrupts generator operation in case of issues with condensate disposal;
- Unified flow and return hydraulic manifolds with reversible threaded connections on the left and right sides, without cut-off between each component and hydraulically balanced;
- Complete premixing, modulating, irradiation, metallic fibre burner, fitted with ignition electrode and ionisation control electrode for each component;
- Pneumatic, double shutter modulating gas valve for each component;
- Air/gas total mixing fan with integrated anti-backflow swing check valve, with electronically variable speed for each component;
- Common air inlet filter for all fans;
- Retractable front control panel [HSCP] for weekly programming of the operating times of the system circuits (up to a maximum of 12 independent system circuits);
- Burner control board for combustion control [BMM];
- Boiler control board [BCM] performs the backup control unit function, ensuring emergency operation (preset fixed flow temperature) in case of control panel failure [HSCP].

Management of:

- 1 direct central heating circuit;
- 1 domestic hot water circuit - DHW production with priority probe (standard), for control via storage tank load pump;
- 1 primary heating circuit in the presence of hydraulic separation, controllable via activation relay for set speed circulator control, or via 0-10V analogue outlet for modulating circulator control;
- Multifunction module kit [SHC], set-up to combine up to a maximum of 4 modules [SHC] to the HSCP control panel (1 supplied as standard - 3 to be provided as optional), each module controls up to 3 user circuits. The multifunction module takes control of the user circuits in addition to the circuits managed by the boiler control board [BCM] (the multifunction module is usually installed in an electrical panel in DIN template).

By connecting 4 SHC boards, it is possible to manage up to 12 different user circuits, for example:

- Direct or mixed central heating circuits;
- Circuits for the production of DHW with DHW storage;
- Circuits for the production of DHW with plate heat exchanger;
- Circuits for the production of DHW with plate heat exchanger and mixing valve;
- Probes supplied by standard:
 - External probe;
 - Storage tank probe (for storage tank load pump control);
 - 3 NTC probes (for controlling the user circuits - to be connected exclusively to the multifunction module [SHC])
- Other devices supplied by standard:
 - Local NTC sensor (one for each heating element);
 - Local limit thermostat (one for each heating element);
 - Flow NTC probe (global);
 - Return NTC probe (global);
 - Emergency NTC probe (global), which is used if emergency operation is activated;
 - Fan air pressure switch;
 - Gas pressure switch;
 - Minimum flue pressure switch;
 - Maximum flue pressure switch;
 - Manual resetting general limit thermostat (only for ARES 350 TEC ErP);
- Adjustable heating flow temperature with factory setting from 25 to 85°C;
- Emergency operation: this enables the system to avoid stopping due to an interruption in communication with the adjusting system or any remote control of the control unit;
- Option of monitoring the state of operation and temperatures;
- Alarm management;
- Set-up for installation of the INAIL safety Kits (ex ISPEL) including hydraulic separator or plate heat exchanger for optimal system management downstream of the boiler;
- Set-up for cascade operation (up to 8 generators).

Category II_{2H3P} appliance, operates with natural gas and L.P.G. CE Marking.

It is available in the model:

- **ARES 150 TEC ErP**
- **ARES 200 TEC ErP**
- **ARES 250 TEC ErP**
- **ARES 300 TEC ErP**
- **ARES 350 TEC ErP**

code 3.025682
code 3.025683
code 3.025684
code 3.025685
code 3.025686



ARES TEC ErP is the new multi-burner, modular, condensation floor standing boiler offered by IMMERGAS for high power systems, ideal for new or replacing obsolete generators serving large volume buildings such as apartment blocks, industrial sheds, shopping malls, school complexes, hospitals etc....

ARES TEC ErP is not just a condensing boiler, but a block that brings together various heating elements/combustion units that are independent yet managed by a single electronic control logic. Each generator is composed of several elements (4 to 8), with modulated power from 22 to 108 kW for each element and specifically: 4 elements for mod. 440, 5 elements for mod. 550, 6 elements for mod. 660, 7 elements for mod. 770, 8 elements for mod. 900.

This unique construction feature offers a broad modulation field which reaches up to 1:40; this enables a very high efficiency ($\eta > 93 + 2 \cdot \log P_n$) in accordance with Legislative Decree 192/05 and subsequent modifications.

The small dimensions combined with high power make ARES TEC ErP the ideal boiler to solve situations where space for the unit is reduced or difficult to reach, thanks to its excellent weight-to-power ratio.

The generator is equipped with an emergency operation function, which prevents the system from being stopped.

The management logic requires simultaneous operation of the maximum number of available heating elements, to always achieve the maximum possible performance (maximum exchange surface is in fact assured).

Despite the high power that is generated, thanks to the innovative combustion circuit technology and the aluminium, silicon and magnesium block, operation is extremely silent (sound emission below 55 dBA).

Also approved for outdoor installation, by standard it has IPX5D electrical protection and an antifreeze protection to -15°C .

The hydraulic and gas connections are NOT reversible, while the flue exhaust can be placed on 3 sides, this enables unprecedented installation flexibility.

The "ecological" soul of ARES TEC ErP is assured by special modulating total premixing boilers with constant CO_2 irradiation that allow low NO_x emissions (the boiler belongs to the most ecological class required by European Standards - Class 6) and low flue gas-sensitive losses.

Electronic management and temperature control are fully automatic and already set for generator operation.

It is also possible to electronically manage up to 8 boilers in cascade by using an optional kit and set up the system for remote management and control.

For a modern design, a number of dedicated accessories are available for completing the unit such as:

Hydraulic kits with INAIL safety (formerly ISPEL) including hydraulic separator; or hydraulic kits with INAIL (formerly ISPEL) safety including plate heat exchanger, both designed to optimise management of the system downstream of the boiler;

Flue exhaust kit;

Acid condensate drain management kit;

Additional system area temperature control kits.

ARES 440 - 900 TEC ErP

2

ARES 440-900TEC ErP FEATURES

Broad range of 5 condensation models for open room base central heating and high performance fan assisted (type B₂₃), with power from 440 to 900 kW, which may be installed individually or as a set (up to 8 generators).

- Single technological block: heating elements installed cast in aluminium, silicon and magnesium;
- Broad modulation field (up to about 1:40);
- Very high seasonal efficiency;
- Dimensional compactness;
- Very low noise, thanks to the advanced combustion features;
- IPX5D electrical protection rating, which can be directly installed outdoors and with temperatures to -15°C;
- Good weight and power ratio;
- Low water content, with consequent quick response time to thermal load changes;
- Single flue exhaust which can be positioned on 3 sides;
- Removable integral panelling with light grey (RAL7035) side air intake grids;
- Insulation, 50 mm thick, with non-allergenic synthetic wool around the aluminium modules;
- Stainless steel condensate collection tank with level sensor which interrupts generator operation in case of issues with condensate disposal;
- Unified flow and return hydraulic manifolds with flanged, non reversible connections, without cut-off between each component and hydraulically balanced;
- Complete premixing, modulating, irradiation, metallic fibre burner, fitted with ignition electrode and ionisation control electrode for each component;
- Pneumatic, double shutter modulating gas valve for each component;
- Air/gas total mixing fan with integrated anti-backflow swing check valve, with electronically variable speed for each component;
- Common air inlet filter for all fans;
- Retractable front control panel [HSCP] for weekly programming of the operating times of the system circuits (up to a maximum of 12 independent system circuits);
- Burner control board for combustion control [BMM];
- Boiler control board [BCM] performs the backup control unit function, ensuring emergency operation (preset fixed flow temperature) in case of control panel failure [HSCP].

Management of:

- 1 direct central heating circuit;
- 1 domestic hot water circuit - DHW production with priority probe (standard), for control via storage tank load pump;
- 1 primary heating circuit in the presence of hydraulic separation, controllable via activation relay for set speed circulator control, or via 0-10V analogue outlet for modulating circulator control;
- Multifunction module kit [SHC], set-up to combine up to a maximum of 4 modules [SHC] to the HSCP control panel (1 supplied as standard - 3 to be provided as optional), each module controls up to 3 user circuits. The multifunction module takes control of the user circuits in addition to the circuits managed by the boiler control board [BCM] (the multifunction module is usually installed in an electrical panel in DIN template).

By connecting 4 SHC boards, it is possible to manage up to 12 different user circuits, for example:

- Direct or mixed central heating circuits;
- Circuits for the production of DHW with DHW storage;
- Circuits for the production of DHW with plate heat exchanger;
- Circuits for the production of DHW with plate heat exchanger and mixing valve;
- Probes supplied by standard:
 - External probe;
 - Storage tank probe (for storage tank load pump control);
 - 3 NTC probes (for controlling the user circuits - to be connected exclusively to the multifunction module [SHC])
- Other devices supplied by standard:
 - Local NTC sensor (one for each heating element);
 - Local limit thermostat (one for each heating element);
 - Flow NTC probe (global);
 - Return NTC probe (global);
 - Emergency NTC probe (global), which is used if emergency operation is activated;
 - Fan air pressure switch;
 - Gas pressure switch;
 - Minimum flue pressure switch;
 - Maximum flue pressure switch;
 - Manual resetting general limit thermostat;
- Adjustable heating flow temperature with factory setting from 25 to 85°C;
- Emergency operation: this enables the system to avoid stopping due to an interruption in communication with the adjusting system or any remote control of the control unit;
- Option of monitoring the state of operation and temperatures;
- Alarm management;
- Set-up for installation of the INAIL safety Kits (ex ISPEL) including hydraulic separator or plate heat exchanger for optimal system management downstream of the boiler;
- Set-up for cascade operation (up to 8 generators), each with its own INAIL safety kit, thanks to the cascade and zone regulator kit (optional).

Category II_{2H3P} appliance, operates with natural gas and L.P.G. CE Marking.

It is available in the model:

- **ARES 440 TEC ErP**
- **ARES 550 TEC ErP**
- **ARES 660 TEC ErP**
- **ARES 770 TEC ErP**
- **ARES 900 TEC ErP**

code 3.025687
code 3.025688
code 3.025689
code 3.025690
code 3.025691

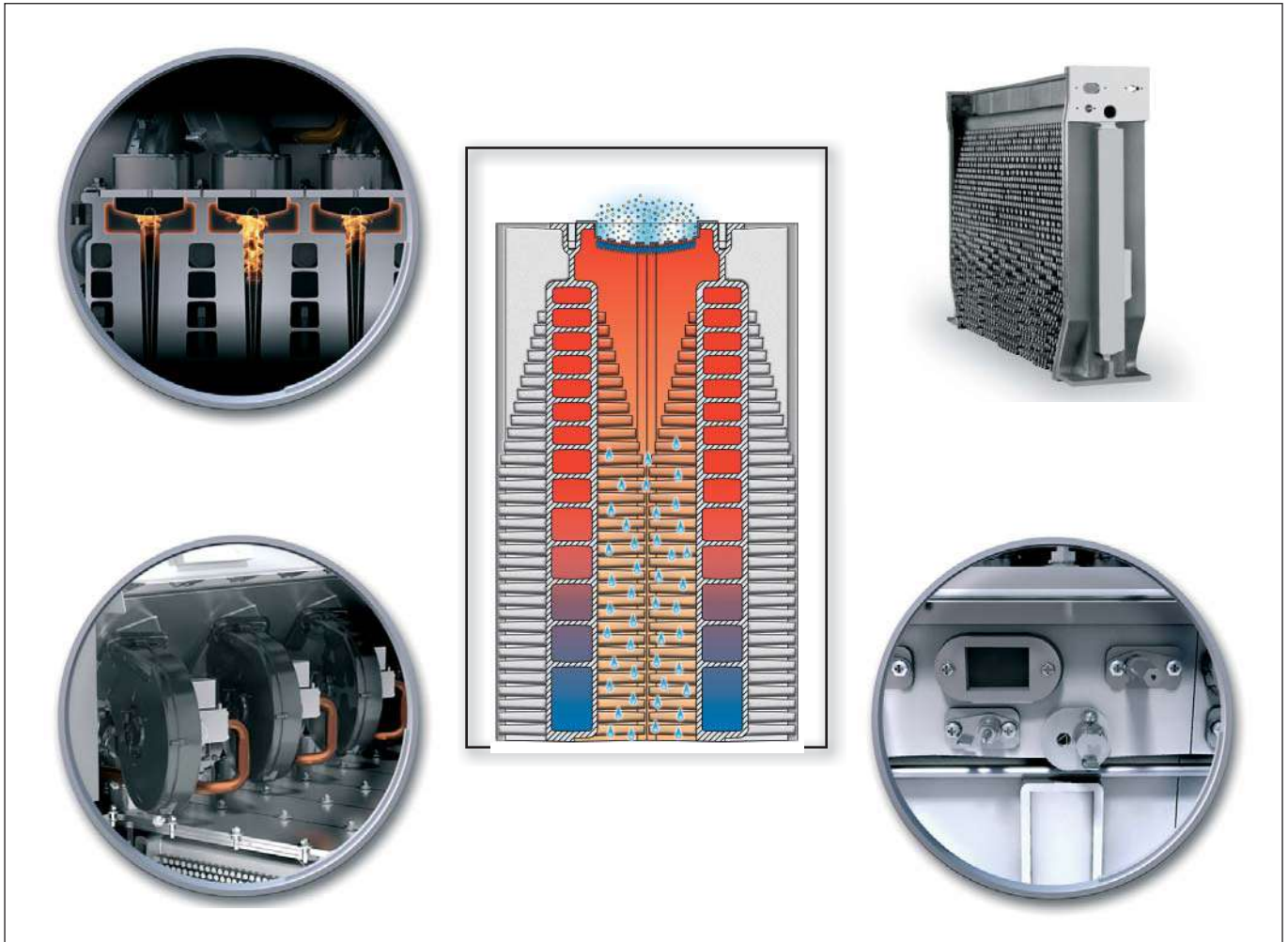

ARES TEC ErP is a thermal module obtained through the assembly of complete combustion units.

Each unit consists of pre-assembled Al/Si /Mg alloy elements (Aluminium, Silicon and Magnesium), combustion chamber kit with burner, fan, gas valve and element board (BMM) is termed "heating element".

Each thermal element continuously and progressively emits power between 12 and 50 kW (models from 150 to 350 kW) and between 22 and 108 kW (models from 440 to 900 kW).

The base element is made up of two half shells which, on the flue side, has dense studding with increasing height towards the drain at the bottom of the element to increase its exchange surface.

Between the 2 half-shells the primary fluid exchange circuit is obtained, which, progressively runs zig/zag, with gradually reduced section, through the entire element, thus assuring exceptional water efficiency.

Each heating element is fitted with:

- premix-modulating irradiation burner
- dual stage modulating gas valve

- ionisation electronic ignition
- NTC temperature control probes
- safety thermostats
- signalling glass.

The drains of the heating elements (flue gas and acid condensates) flow into a special drainage manifold, made of stainless steel.

Each "heating element" is fitted with a modulating fan which is a decisive component for perfect combustion and therefore optimal output, in fact the fan sucks and mixes the correct amount of air and gas and pushes it through the flue gas swing check anti-backflow valve, inside the combustion chamber.

The fan rev number, along with gas valve opening and flame control, are directly programmed and controlled by the electronics of each burner which are, in turn, controlled by the boiler electronics.

The power modulation depends on fan speed and is based on the difference between the temperature required by the system, the maximum set one and the one actually measured.

ARES TEC ErP

3.1 COMPONENTS AND CONSTRUCTION TECHNOLOGY

Combustion

The gas valve is opened through a "Venturi effect" in the fan auger and the mixture of air and gas takes place inside it before being introduced into the combustion chamber (Premix).

This perfect mix combines air and gas in always proportioned parts to achieve "irradiation combustion" through the multigas burner.

This is the most efficient system for thermal energy transmission.

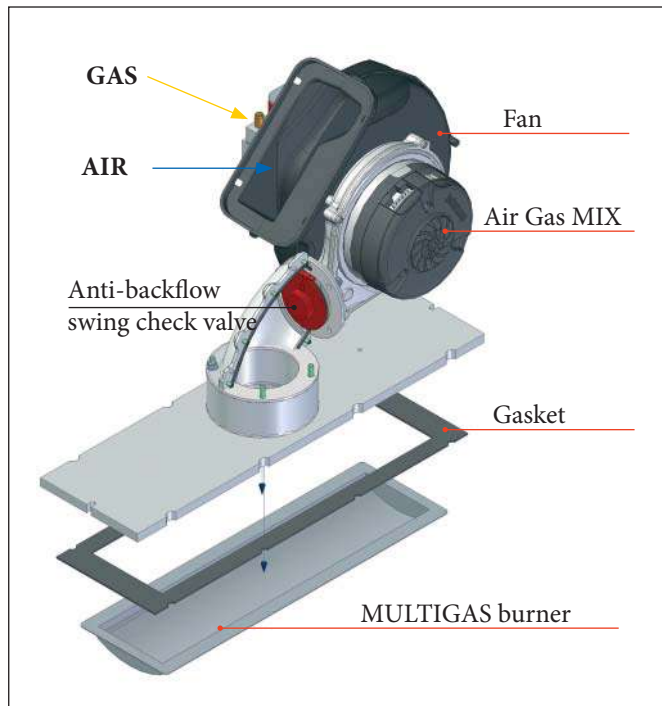

The wide surface that combustion takes place on assures:

- low combustion temperature;
- reduced turbulence with the following advantages: long life thanks to the low thermal and mechanical stress and the physical FeCrAlloy fibre fabric of the burner which, thanks to its physical chemical structure, is a perfect irradiation device;
- high combustion silence due to low pressures and the anti-resonance structure of the fan capable of developing a soft flame;
- simple maintenance thanks to the reduced use of components and easy accessibility;
- greater energy transmitted compared to a conventional burner at the same flame temperature;
- assured operation safety thanks to the absence of turbulence,
- limited production of pollutants for the complete oxidation of methane molecules;
- optimal combustion efficiency;
- efficiency optimisation thanks to minimum flue gas temperature and limited "air excess";
- minimum NOX emissions (class 5, the most ecological required by European standards).

Option of calibration based on the system's Thermal Demand

This function drastically reduces the number of times generators are switched on and off: this leads to greater efficiency and less flue leaks (due to burner shutdown) and longer life span of moving parts and ignition systems.

Low water content and high modulation speed with maximum ratio of up to 1:40

For the majority of the heating period, the generator operates under reduced load, operating well below 30%.

ARES TEC ErP adapts its power to these requirements in real time thanks to its low water volume and, being equipped with a modulating pump, minimizes electrical consumption.

Class A electronic pumps at variable speeds (optional) serving the generator for maximum condensate production

Use of electronic pumps at variable speeds enhances condensate production and therefore fast economic investment recovery.

All this to offer the user the opportunity to save, with maximum thermal and DHW comfort, at a lower noise level than traditional boilers.

Temperature control

ARES TEC ErP temperature control has been designed on two levels represented by as many devices installed on the boiler: "HSCP" and "BMC"

The boiler manager temperature controller (TGC), manages ARES TEC ErP operation both in terms of modulation and sliding temperature operation.

The HSCP control panel [Heating System Control Panel] in the boiler is equipped with backlit LCD display where it is possible to program:

- time slots,
- daily and weekly programs,
- climatic curves,
- anti-legionella and other settings.

The basic electronics of the boiler called BCM (Boiler Control Manager) has been designed to control:

- a circulator for direct flow to the system;
- a circulator for controlling a DHW (Domestic hot water) storage tank;
- a circulator for a primary loop.

ARES TEC ErP is also supplied as standard with external probe, 1 system area flow probe (e.g. for mixed zone 2 control) and 1 storage tank probe.

The management control until (BMC), in case of anomalies that cannot be reset to (HSCP) or for operation emergencies, enables ARES TEC ErP to be activated in emergency mode by bypassing the (HSCP) temperature control and activating the boiler at a pre-settable fixed flow temperature.

This makes the ARES TEC ErP boiler twice as safe with the advantage that it is possible to avoid requiring a back-up generator in large power plants.

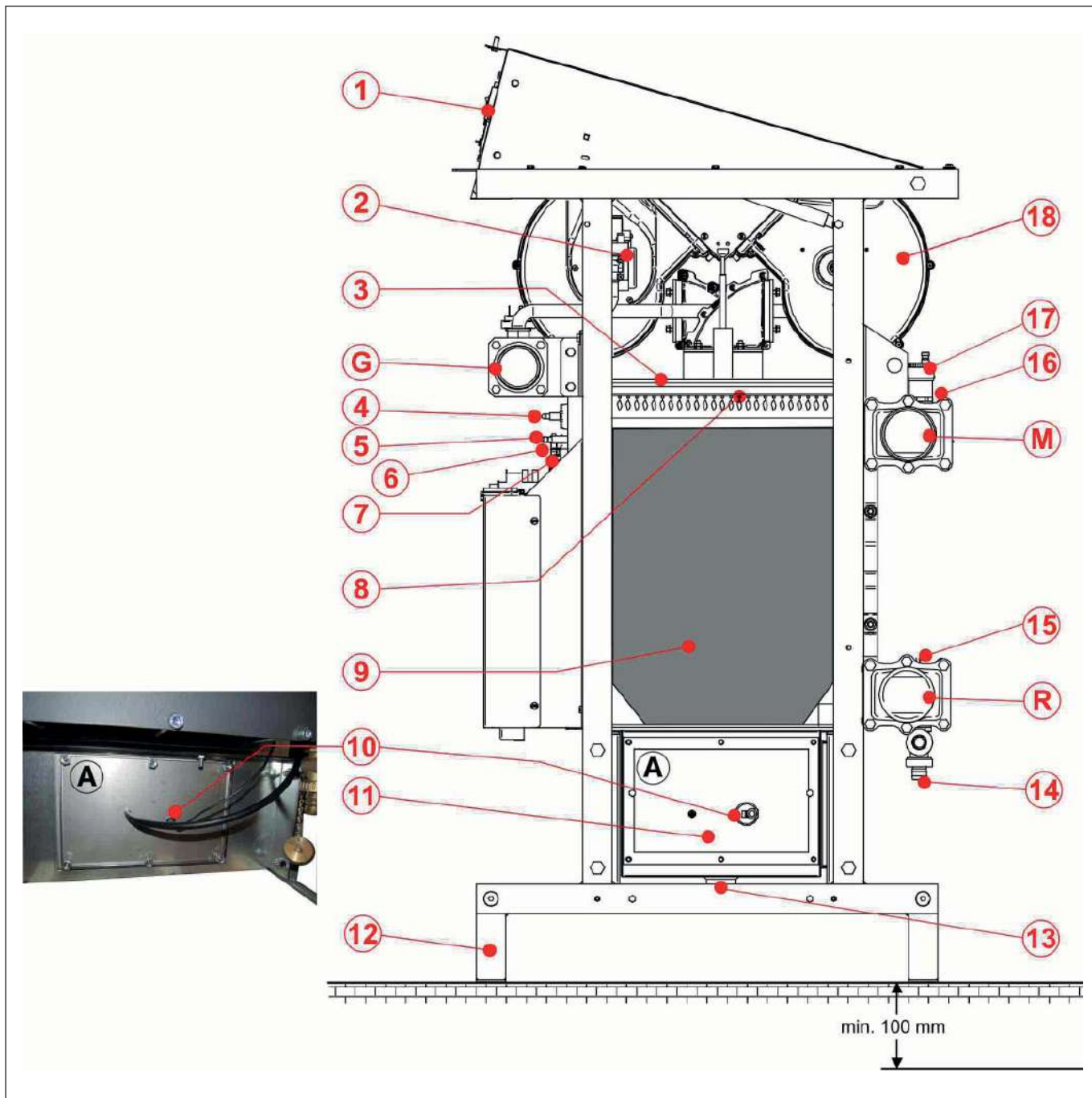

KEY		
1	HSCP	Control panel
2	VG	Gas valve
3		Burner Cover
4	DET. E.	Ignition electrode
5	IGN. E.	Detection electrode
6	SR	Local heating sensor
7	TL	Limit Thermostat
8		Burner
9		Silicon Aluminium Exchanger
10	SL	Condensate level sensor

11		Condensate collection pan / Chimney fitting
12		Frame
13		Condensate drain outlet
14		Draining Tap
15	SRR	Global Return Sensor
16	SMG	Global Flow Sensor
17		Automatic air bleed valve
18		Fan
19	PF min	Minimum flue pressure switch
20	PF	Flue pressure switch

ARES 150 - 350 TEC ErP

4.1 MAIN COMPONENTS ARES 150-350 TEC ErP

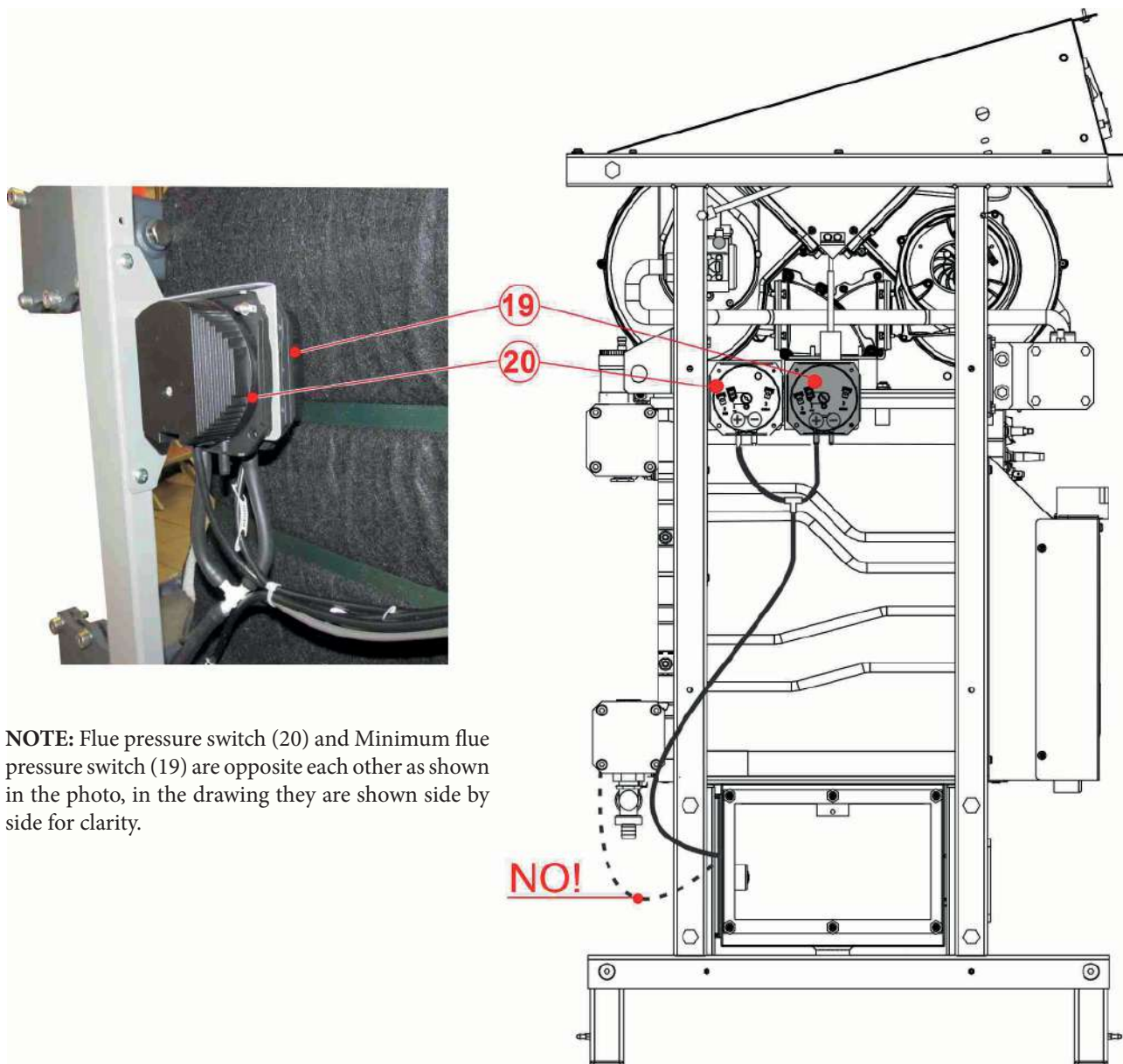

NOTE: Flue pressure switch (20) and Minimum flue pressure switch (19) are opposite each other as shown in the photo, in the drawing they are shown side by side for clarity.

- Flue outlet:** RIGHT side (supply condition) - LEFT side and REAR side (2 optional separate rear flue exhaust kits).
- Flow:** RIGHT side (supply condition) - LEFT side
- Return:** RIGHT side (supply condition) - LEFT side
- Gas intake:** RIGHT side (supply condition) - LEFT side

If it is necessary to position the flue exhaust, on the **left** side of the boiler, it is necessary to move cover "A" with relative wiring, level sensor and pressure switch pipe, on the rear side of the boiler. The rear cover (previously removed) must be put back on the right side of the boiler.

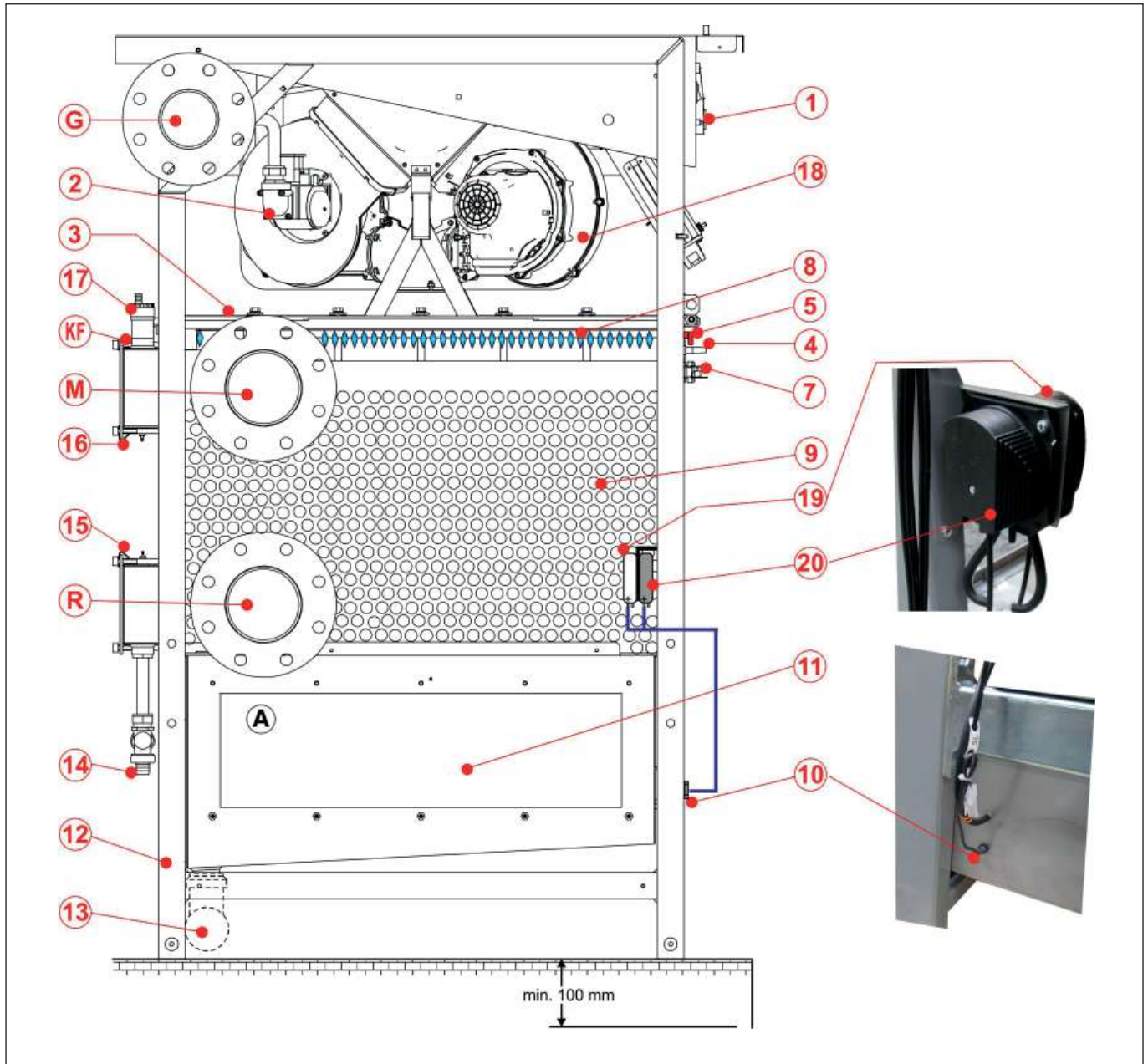

KEY		
1	HSCP	Control panel
2	VG	Gas valve
3		Burner Cover
4	IGN. E.	Ignition electrode
5	DET. E.	Detection electrode
7	TL	Limit Thermostat
8		Burner
9		Silicon Aluminium Exchanger
10	SL	Condensate level sensor
11		Condensate collection pan / Chimney fitting
12		Frame
13		Condensate drain outlet

14		Draining Tap
15	SRR	Global Return Sensor
16	SMG	Global Flow Sensor
17		Automatic air bleed valve
18		Fan
19	PF min	Minimum flue pressure switch
20	PF	Flue pressure switch

Flue outlet: LEFT side (supply condition), or RIGHT side, REAR (no accessory required to move flue exhaust position).

Flow: LEFT side

Return: LEFT side

Gas inlet: LEFT side

ARES 150 - 350 TEC ErP

6

MAIN DIMENSIONS ARES 150-350 TEC ErP

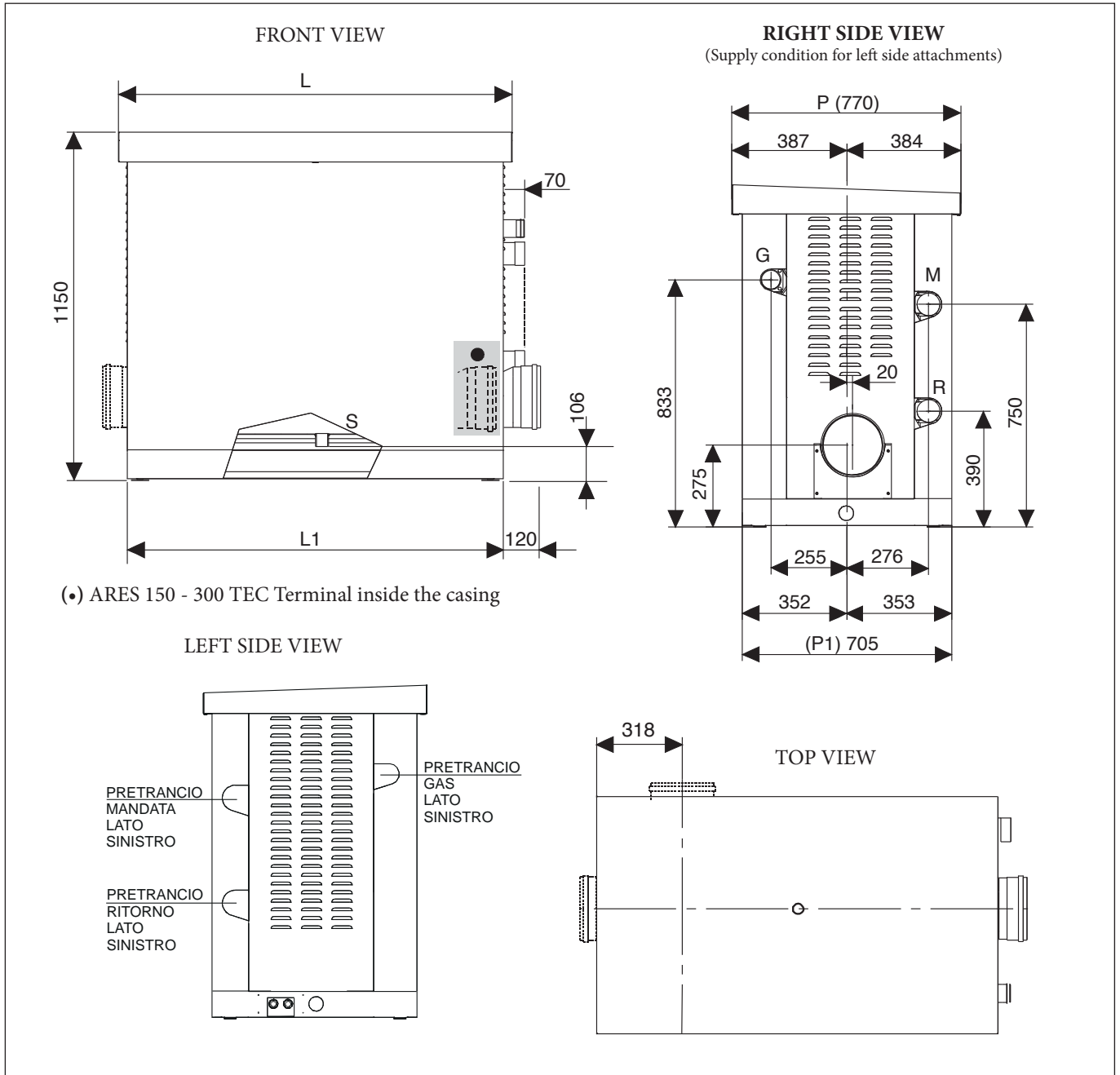

ARES TEC ErP		150	200	250	300	350
Dimensions	Unit					
Heating elements	No.	3	4	5	6	7
Height	mm	1150	1150	1150	1150	1150
Width "L"	mm	764	1032	1032	1300	1300
Width "L1"	mm	706	974	974	1242	1242
Depth "P"	mm	770	770	770	770	770
Depth "P1"	mm	705	705	705	705	705
Attachment sizes						
"G" Gas fitting (threaded)	mm (inch)	50 (2)	50 (2)	50 (2)	50 (2)	50 (2)
"M" System flow (threaded)	mm (inch)	64 (2½)	64 (2½)	64 (2½)	64 (2½)	64 (2½)
"R" System return (threaded)	mm (inch)	64 (2½)	64 (2½)	64 (2½)	64 (2½)	64 (2½)
Chimney fitting	mm	150	150	200	200	200
"S" condensate drain	mm	40	40	40	40	40

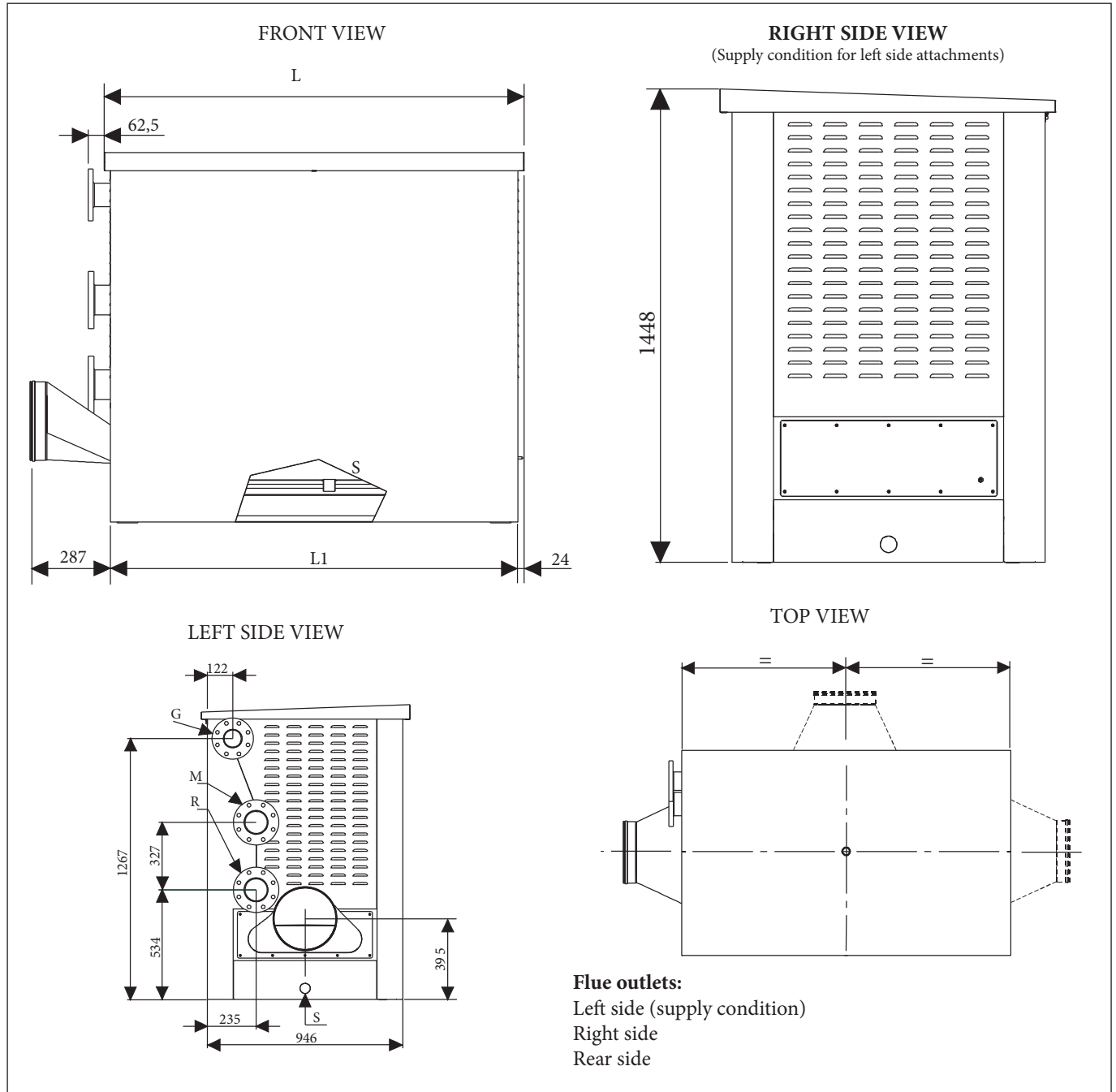

ARES TEC ErP		440	550	660	770	900
Dimensions	Unit					
Heating elements	No.	4	5	6	7	8
Height	mm	1448	1448	1448	1448	1448
Width "L"	mm	1087	1355	1355	1623	1623
Width "L1"	mm	1039	1307	1307	1575	1575
Depth	mm	946	946	946	946	946
Attachment sizes						
"G" Gas fitting (flanged)	mm (inch)	80 (3)	80 (3)	80 (3)	80 (3)	80 (3)
"M" System flow (flanged)	mm (inch)	100 (4)	100 (4)	100 (4)	100 (4)	100 (4)
"R" System return (flanged)	mm (inch)	100 (4)	100 (4)	100 (4)	100 (4)	100 (4)
Chimney fitting	mm	250	250	300	300	300
"S" condensate drain	mm	40	40	40	40	40

ARES 150 - 350 TEC ErP

8

HYDRAULIC AND FLUE CONNECTIONS ARES 150-350 TEC ErP

The ARES 150-350 TEC ErP boiler leaves the factory with hydraulic (flow and return), gas and flue outlet connections located on the right side of the boiler. To invert the connections from the right side (standard supply) to the left side it is necessary to carry out the operations below, depending on the connection that needs to be moved.

Reversing flue exhausts.

To move the flue exhaust from Rh to Lh simply switch the two sides of the casing around.

To move the exhaust located on the rear side, proceed as described below, depending on the boiler model.

- only for models 250 - 300 - 350 (Fig. A) it is necessary to request the rear flue exhaust kit Ø 200 made of the "T" and a closing

metal-sheet plate over the hole on the Rh side of the casing.
- only for models 150 - 200 (Fig. B) it is necessary to request the rear flue exhaust kit Ø 150 made of a closing sheet metal plate over the hole on the Rh side of the casing.

Reversing Gas (Fig. C).

Switch the blind flange around with the flanged stub pipe.

Reversing system flow and return (Fig. D).

Switch the blind flange around with the flanged stub pipe.

N.B: When the position of the connections is reversed, the relative flow probe (SMG), return probe (SRR) and manual reset Safety Thermostat (TLG - the latter only for model 350) must also be moved.

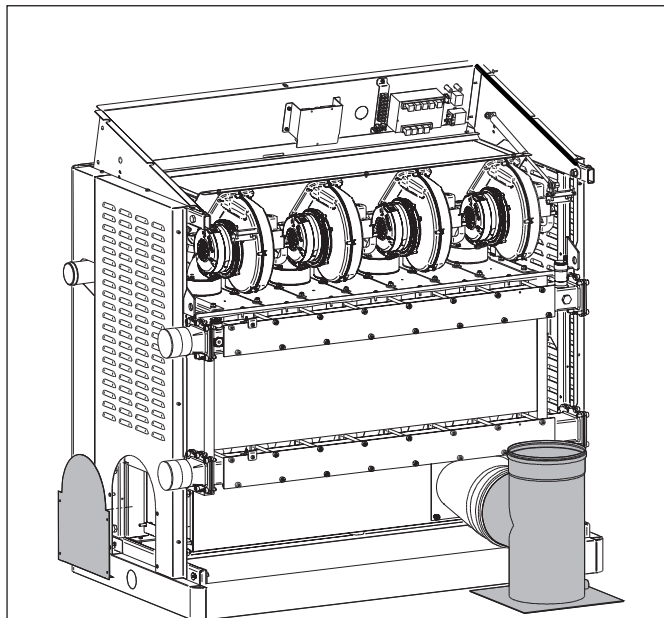

Fig. A

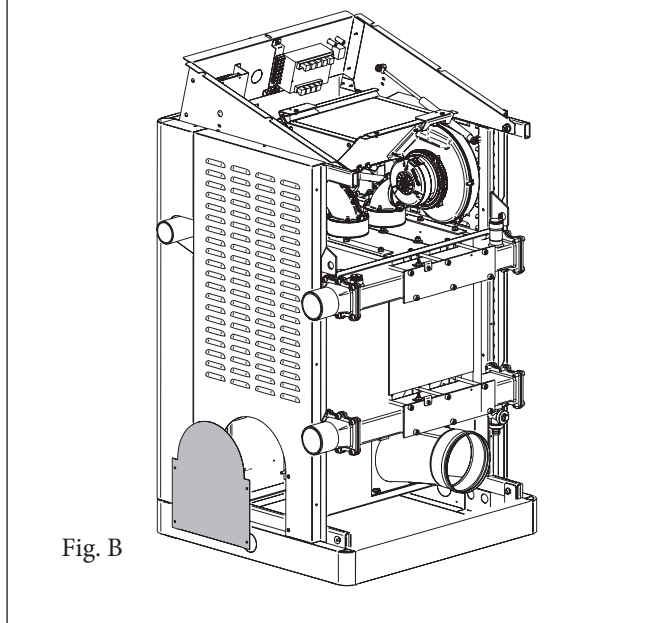

Fig. B

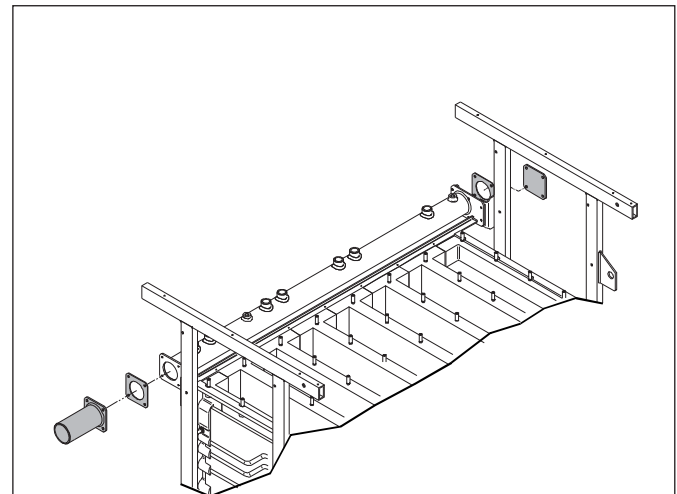

Fig. C

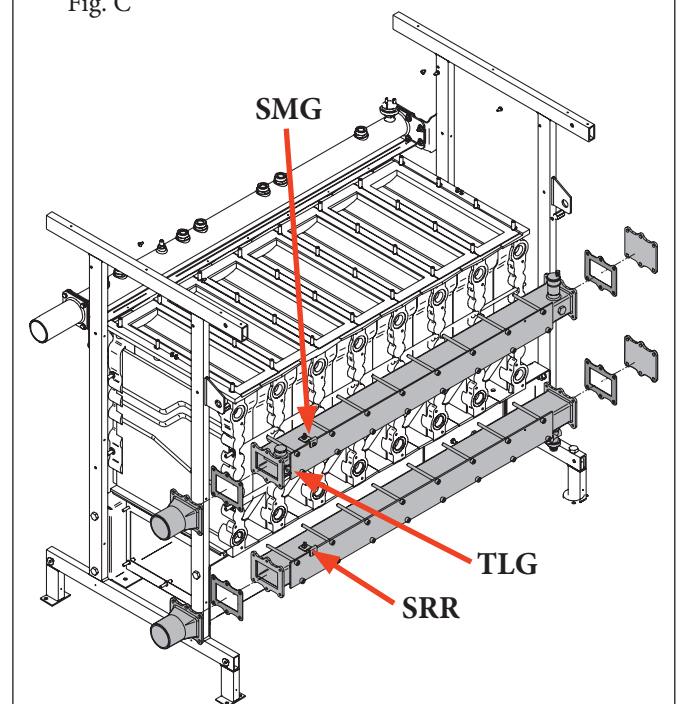
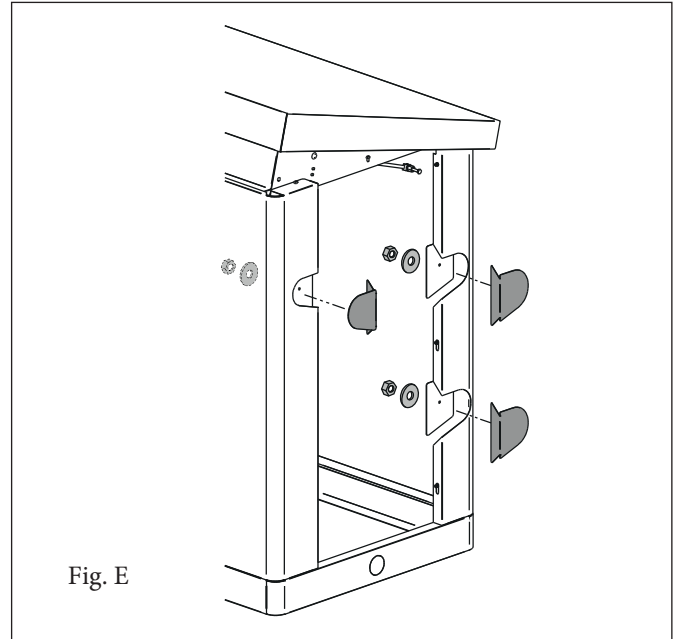

Fig. D

Reversing ARES 150-350 TEC ErP hydraulic attachments (Fig. E).

Remove the pre-sectioned part on the attachments that you intend to move to the opposite side (only one or both) and close the Rh side of the casing with the caps supplied with the boiler.



9

HYDRAULIC AND FLUE CONNECTIONS ARES 440-900 TEC ErP

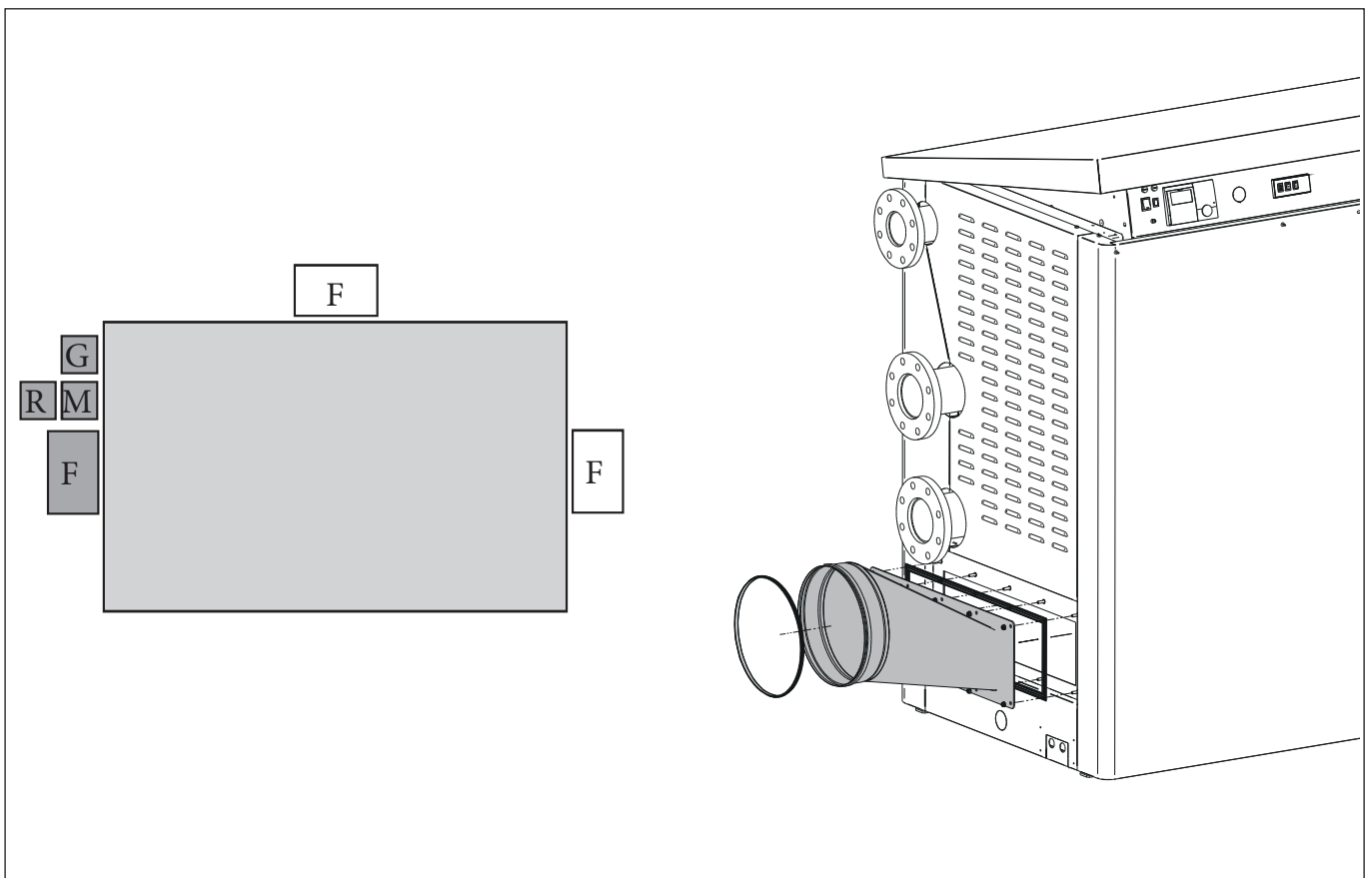

The ARES 440-900 TEC ErP boiler leaves the factory with the hydraulic (flow and return) and gas connections on the left side of the boiler and they CANNOT be moved.

The standard flue manifold is set on the left side, it is also possible to set up the outlet on the right and rear side.

ARES TEC ErP

10

CONNECTION TO THE FLUE AND FLUE OPTIONALS

Code 3.023701 only for ARES 150-200 TEC ErP

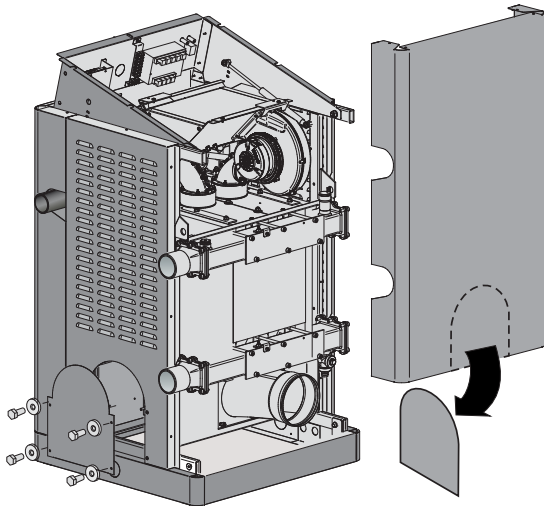

Code 3.023674 only for ARES 250-300-350 TEC ErP

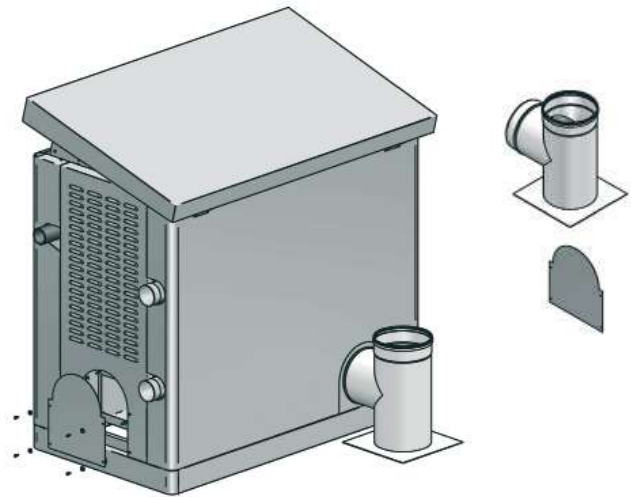

Code 3.023675 for all ARES TEC ErP models

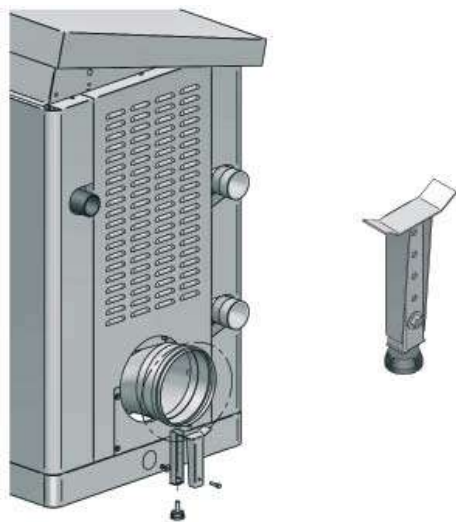

Flue Kit

Rear flue exhaust kit Ø 150 for ARES 150-200 TEC ErP
code 3.023701

Rear flue exhaust kit Ø 200 for
ARES 250-300-350 TEC ErP
code 3.023674

Side flue outlet support kit (for all models)
code 3.023675

11

CHIMNEY SIZING GUIDELINE

Flue sizing according to DIN 4705

Flue gasses temperature **40°C**
 Available positive pressure **40 Pa**

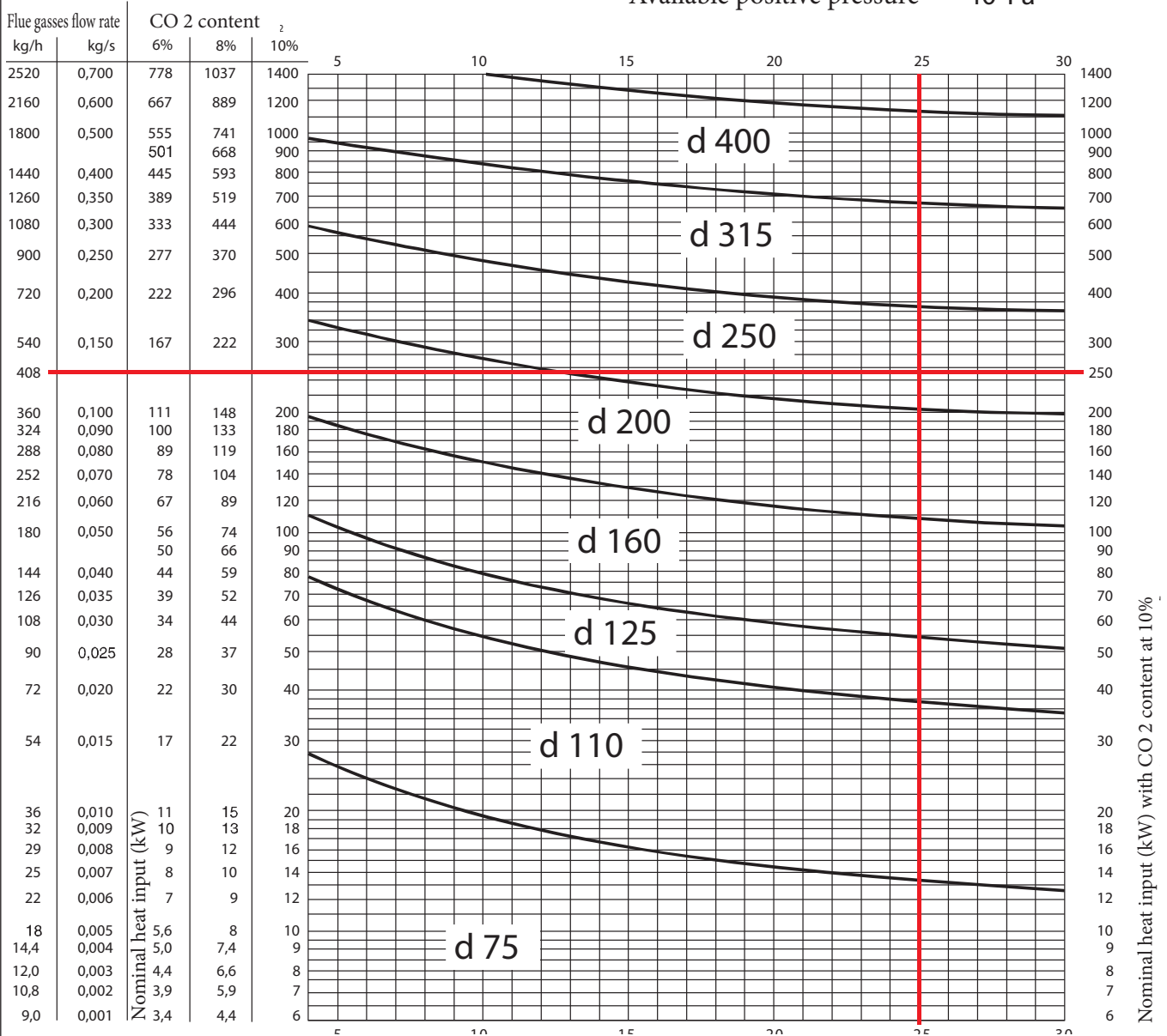

Example:

ARES 250 TEC ErP
 Maximum flue flow rate = 408.6 Kg/h
 Height of flue = 25 m
 Diameter = 250 mm

N.B.: The diagram provides rough values: in any case, the flue must be designed by a qualified professional in compliance with legislation and technical standard in force.

In a condensing boiler, flue gases are dispersed at reduced temperature, it is therefore necessary for the chimney to be perfectly impermeable to combustion product condensate and built with suitable corrosion-resistant materials.

N.B.: for the sizing of the exhaust system for combustion products, refer to the relative regulations in force (e.g. UNI EN 13384). The evacuation pipe must be built with materials that are resistant to combustion products.

ARES TEC ErP

12

HEATING CONTROL UNIT POSITIONING VALUES

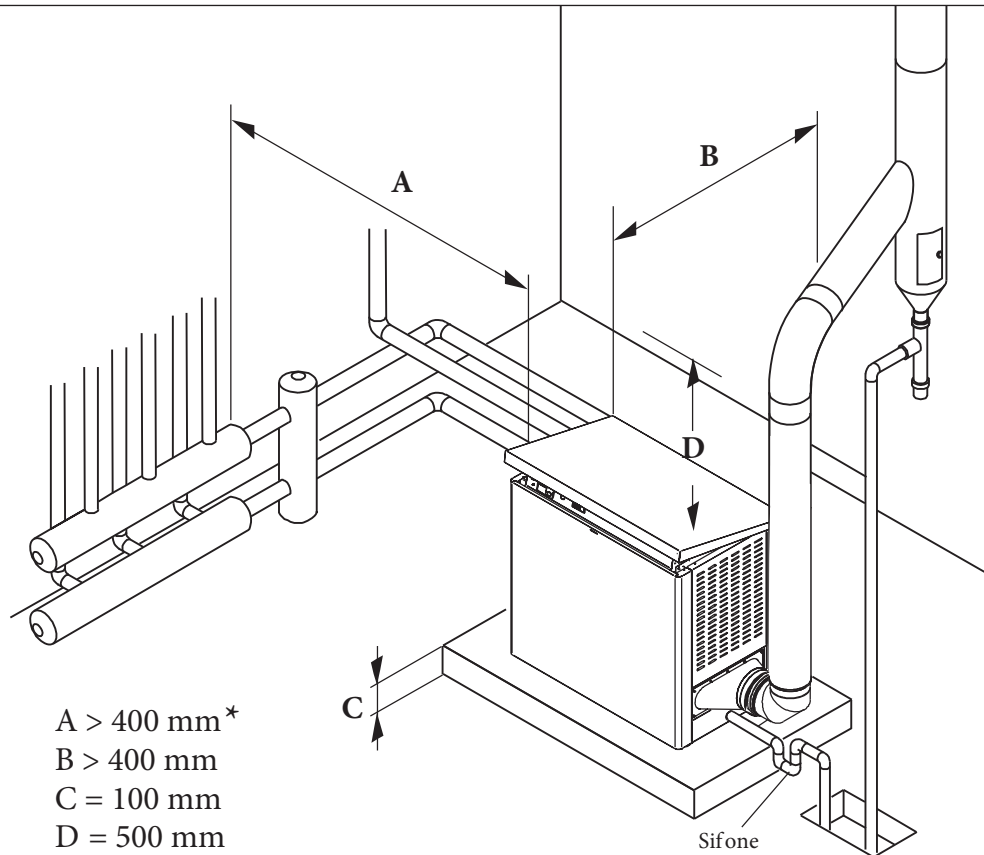

Attention: Observe the minimum clearance distances shown in the picture to perform normal maintenance and cleaning operations

*Also consider the space occupied by the INAIL safety kits

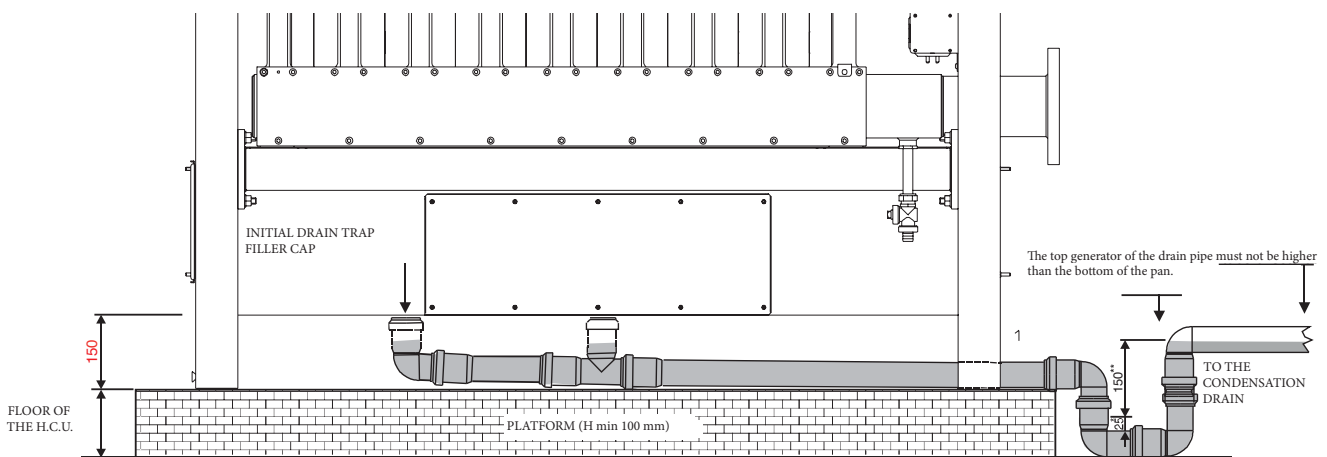

* 25 mm = Minimum safety drain trap enforced by regulation

** 150 = Minimum head with boiler operating at maximum power

Attention: The boiler must be placed on a flat platform that is sufficiently sturdy in size, in plan, no smaller than the boiler measurements and with a minimum height of at least 100 mm so that the condensate drainage trap can be installed.

If you do not want to or are not able to create a platform, it is possible to install the boiler on the floor and set up a sample point next to the boiler of depth of 100 mm to place the drain trap.

13 CONDENSATE TREATMENT

Condensate neutralisers are specifically designed to neutralise acidic waters produced by condensing boilers. Condensation water has an acid pH, passing through the neutraliser mineral it slowly dissolves the mineral, bringing the pH to an average value of 6.5. Value that the condensate can be drained at. Condensate neutralisers are made with special patented bulk-heads that convey the condensate into a series of forced passages where it comes into contact with the mineral for an above average amount of time.

The condensate is flushed through an area filled with a granular neutralising material, which also has an integrated filtering layer. The kit includes a complete granulate load. **N.B.** For installations with sets of higher capacity boilers, several neutralisers can be installed in parallel. The kit does not support installation outside the building.

Key:

- 1 - Hose union Inlet
- 2 - Hose union Outlet
- 3 - Hose union Overflow
- 4 - Filters

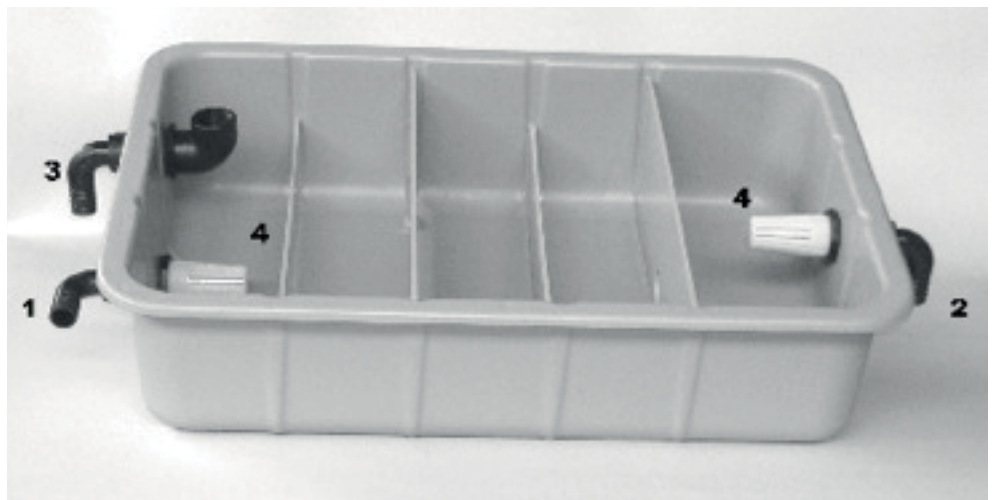

Technical data:

Max Flow Rate	l/h	300
Condensing Boiler Max Flow rate	kW	1500
Total length	mm	670
Maximum width	mm	470
Maximum height	mm	170
Inlet Height	mm	30
Exhaust Height	mm	100
Mineral	kg	25
Hose union Inlet/Outlet/Overflow	mm	25
Overall mass at shipment	kg	33

Condensate drain management kit	
Condensate passivator kit up to 1500 kW (includes a complete granulate load) code 3.023662	Granulate kit for condensate passivator (25 kg) code 3.023663

ARES TEC ErP

14

FEED WATER TREATMENT

Treating the feed water allows you to prevent problems and maintain the function and efficiency of the generator over time.

Reference standards:

- UNI 8065/1989 "Water treatment in thermal heating systems for civil use";
- UNI 8364/2007 on central heating systems parts 1-2-3.

The purpose of this treatment is to eliminate or significantly reduce problems that can be outlined as: deposits, corrosion, biological growths (mould, mushrooms, algae, bacteria, etc.).

The chemical analysis of the water provides a lot of information on the state and "health" of the system.

The pH level is a numerical indication of the acidity or alkalinity of a solution:

The pH scale goes from 0 to 14, where 7 stands for neutral.

Values below 7 indicate acidity, values above 7 indicate alkalinity.

The ideal pH value in central heating systems with aluminium boilers is between 6.5 and 8, with a hardness of 15°F.

Water in a system with a pH value outside of this range considerably accelerates the destruction of the protective oxide layer which naturally forms inside the aluminium bodies, and would not occur naturally: if the pH level is lower than 6 it contains acid, if it is above 8 the water is alkaline, either due to an alkaline treatment (for example phosphates or glycols operating as antifreeze) or in some cases the natural generation of alkalis in the system.

Vice versa, if the pH value is between 6.5 and 8, the aluminium surfaces in the body are passivated and protected from further corrosive attacks.

N.B.: To minimise corrosion, it is essential to use a corrosion inhibitor. In order for it to work efficiently, however, the metal surfaces must be clean.

The best inhibitors on the market also contain an aluminium protection system that stabilises the pH levels of the filling water, preventing sudden changes (buffer effect).

It is advisable to systematically check the pH value of the water in the system. In order to do so a chemical laboratory analysis is not required, but a simple check using a analysis "kit" contained in a carry case, easily available on the market.

It is recommended to set up the devices as shown in the picture on the feed circuit before placing it in the central heating system.

NOTE: The coupling must be set up on the return pipe to the primary circuit downstream of the circulator pump.

All of the precautions required to avoid the formation and localisation of oxygen in the water of the system. **For this reason the plastic pipes used in the under-floor central heating systems must not be permeable to oxygen.**

Make sure that any antifreeze products are compatible with aluminium and any other parts and materials in the system.

Example of water treatment unit

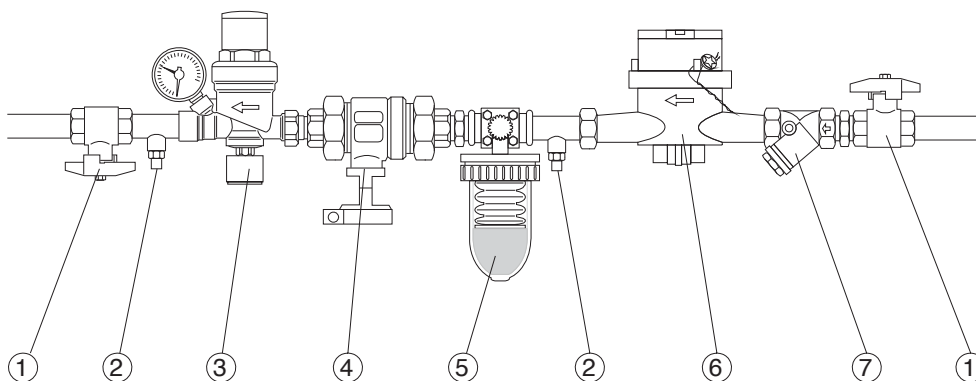

Key:

- 1 - Ball valve
- 2 - Sample trap
- 3 - Filling unit
- 4 - Disconnect
- 5 - Water treatment unit
- 6 - Litre meter (recommended)
- 7 - "Y" filter

15 INAIL SAFETY KIT INCLUDING CIRCULATOR PUMP AND HYDRAULIC SEPARATOR (MODELS UP TO 350 kW)

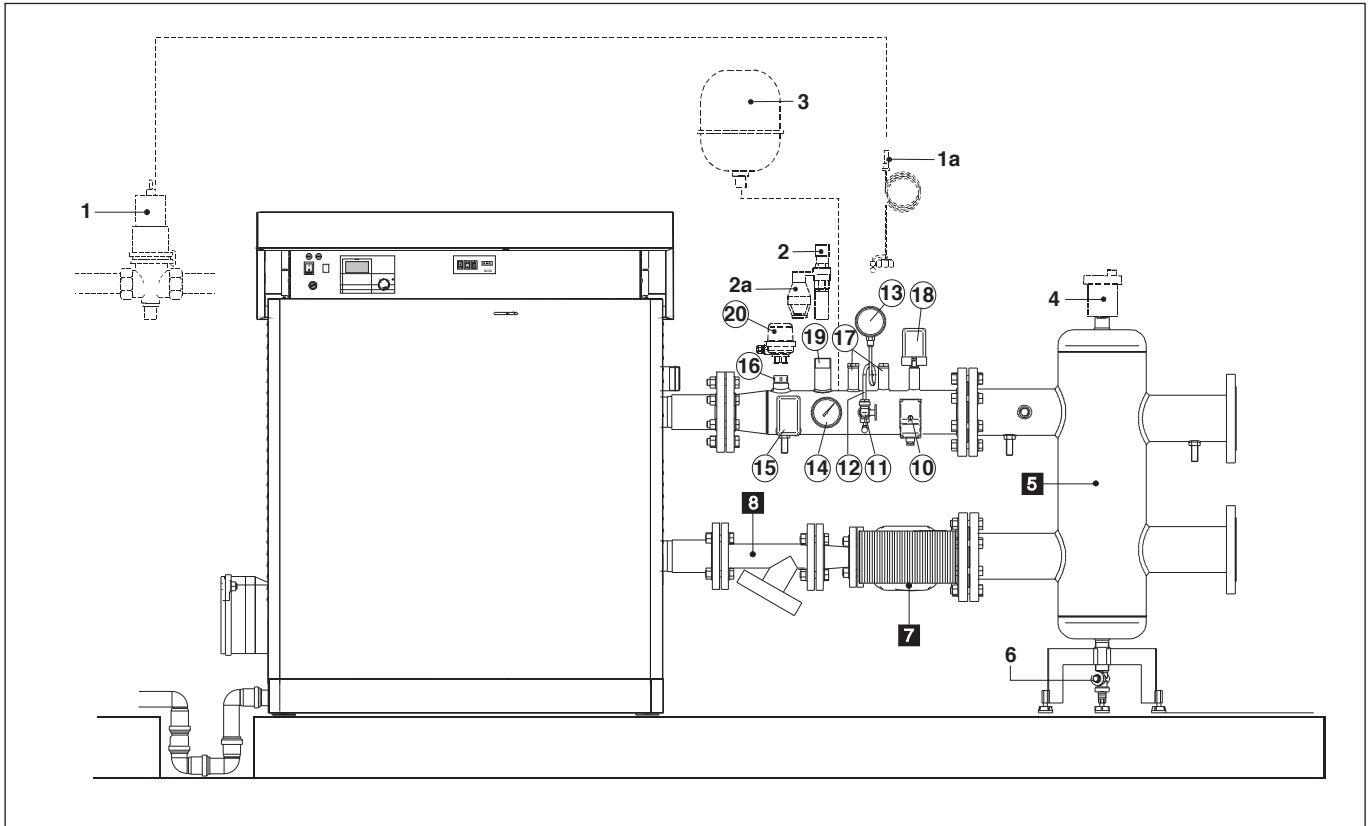

This kit completes the primary loop by integrating:

- INAIL safety kit complete and up-to-date to the R 2009 set;
- "Y" filter;
- Modulating pump with low electrical consumption (class A);
- Hydraulic separator.

Attention: The boiler is **not** equipped with an expansion vessel on the system. It is mandatory to install a closed expansion vessel to assure correct boiler operation.

The expansion vessel must be compliant with standards in force. The dimensions of the expansion vessel depend on the data relative to the central heating system. Install a vessel whose capacity responds to the requisites of the Standards in force ("R" stamp).

Safety devices:

- 1) Fuel shut-off valve - NOT INCLUDED
- 2) Safety valve, outside generator - NOT INCLUDED
- 2a) Visible draining funnel - NOT INCLUDED

Set up a safety valve, on the flow pipe, sized for boiler capacity, within 0.5 m of the boiler, and in compliance with regulations in force.

Attention: remember it is forbidden to set up any type of cut-off device between the boiler and the safety valve, and it is also advisable to use valves for operation that does not exceed the maximum allowed operating pressure.

Protection devices:

- 10) Safety thermostat (immovable calibration < 100°C)
- 15) Minimum pressure switch (can be calibrated at 0.5-1.7 bar)
- 16) G1" Sleeve
- 18) Safety pressure switch (can be calibrated at 1-5 bar)

Control devices:

- 13) Pressure gauge (NOT INCLUDED) with (12) damper pipe and (11) G $\frac{1}{2}$ " pressure gauge-holder tap
- 14) G $\frac{1}{2}$ " Thermometer (max 120°C full scale)
- 17) G $\frac{1}{2}$ " connection sample points for potential (V.I.C.)
- 19) G1 $\frac{1}{4}$ " Stub pipe: for connecting the safety valve
- 20) Flow switch in case water flow is interrupted
- 3) Expansion vessel - NOT INCLUDED

Other components:

- 8) Y filter with DN 50 flanged connections
- 7) Modulating pump with low electrical consumption (class A) type: Wilo STRATOS 40/1-4 (mod. 150) / Wilo STRATOS 40/1-8 (mod. from 200 to 250) / Wilo STRATOS 40/1-12 (mod. from 300 to 350)
- 5) Hydraulic separator with DN 100 flanged connections fitted with supporting feet
- 4) Vent valve - NOT INCLUDED
- 6) Draining valve - NOT INCLUDED

The appropriately sized safety valve, pressure gauge and expansion vessel must be added separately.

ARES 440 - 900 TEC ErP

16 INAIL SAFETY KIT INCLUDING CIRCULATOR PUMP AND HYDRAULIC SEPARATOR (MODELS FROM 440 UP TO 900 kW)

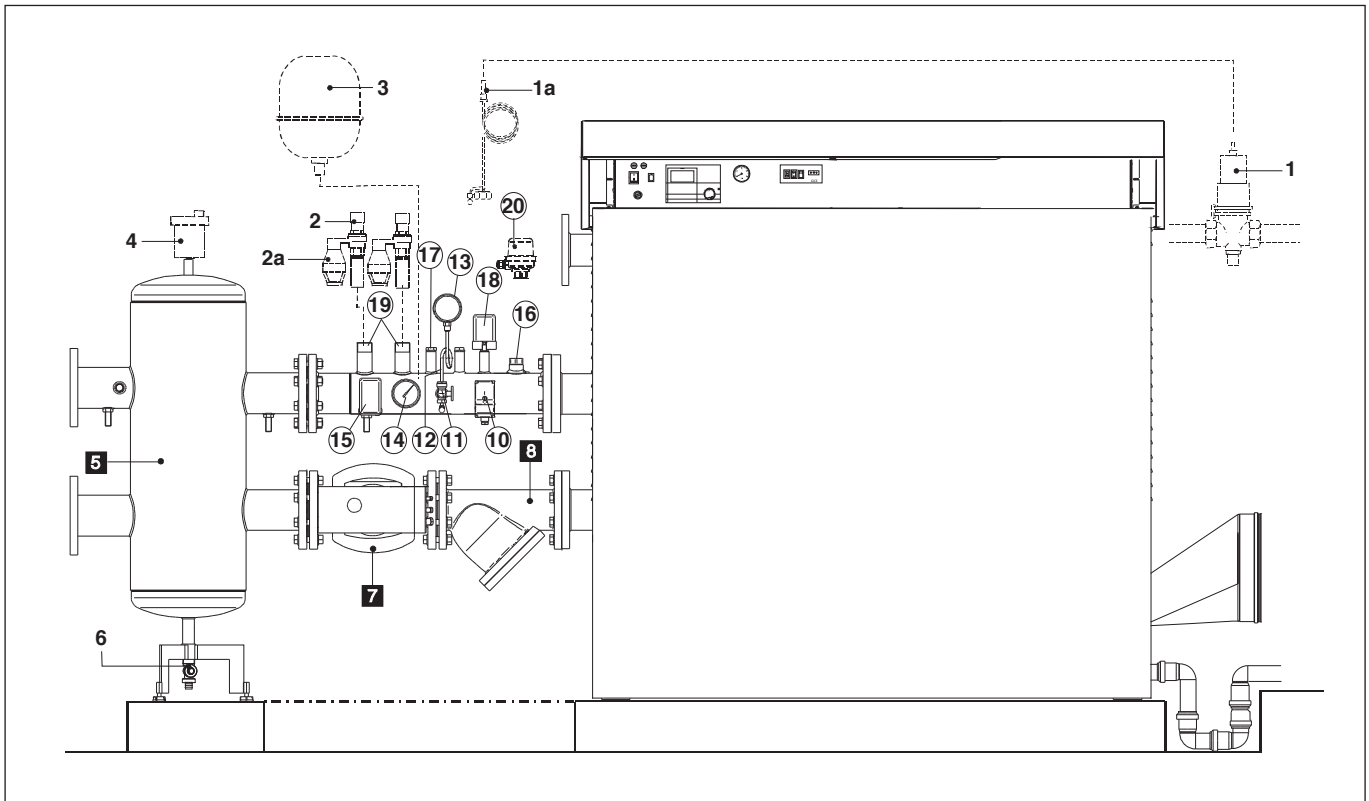

This kit completes the primary loop by integrating:

- INAIL safety kit complete and up-to-date to the R 2009 set;
- "Y" filter;
- Modulating pump with low electrical consumption (class A);
- Hydraulic separator.

Attention: The boiler is **not** equipped with an expansion vessel on the system. It is mandatory to install a closed expansion vessel to assure correct boiler operation.

The expansion vessel must comply with the European Standards in force.

The dimensions of the expansion vessel depend on the data relative to the central heating system. Install a vessel whose capacity responds to the requisites of the Standards in force ("R" stamp).

Safety devices:

- 1) Fuel shut-off valve - NOT INCLUDED
- 2) Safety valve, outside the generator - NOT INCLUDED
(There are 2 safety valves for models 660-770-900)
- 2a) Visible draining funnel - NOT INCLUDED

On the flow pipe, set up a safety valve (or 2 for models 660-770-900) sized for the boiler capacity, within 0.5 m of the boiler, and in compliance with regulations in force.

Attention: remember it is forbidden to set up any type of cut-off device between the boiler and the safety valve, and it is also advisable to use valves for operation that does not exceed the maximum allowed operating pressure.

Protection devices:

- 10) Safety thermostat (immovable calibration < 100°C)
- 15) Minimum pressure switch (can be calibrated at 0.5-1.7 bar)
- 16) G1" Sleeve
- 18) Safety pressure switch (can be calibrated at 1-5 bar)

Control devices:

- 13) Pressure gauge (NOT INCLUDED) with (12) damper pipe and (11) G $\frac{1}{2}$ " pressure gauge-holder tap
- 14) G $\frac{1}{2}$ " Thermometer (max 120°C full scale)
- 17) G $\frac{1}{2}$ " connection sample points for potential (V.I.C.)
- 19) G1 $\frac{1}{4}$ " Stub pipes: for connecting the safety valves
- 20) Flow switch in case water flow is interrupted
- 3) Expansion vessel - NOT INCLUDED

Other components:

- 8) Y filter with DN 65 flanged connections (mod. from 440 to 770) and DN 100 (mod. 900)
- 7) Modulating pump with low electrical consumption (class A) type: Wilo STRATOS 65/1-12 (mod. from 440 to 770) / Wilo STRATOS 100/1-12 (mod. 900)
- 5) Hydraulic separator with DN 100 flanged connections fitted with supporting feet
- 4) Vent valve - NOT INCLUDED
- 6) Draining valve - NOT INCLUDED

The appropriately sized safety valve/valves, pressure gauge and expansion vessel must be added separately.

ARES 150 - 350 TEC ErP

17

PRIMARY LOOP DIMENSIONS WITH HYDRAULIC SEPARATOR (MODELS UP TO 350 kW)

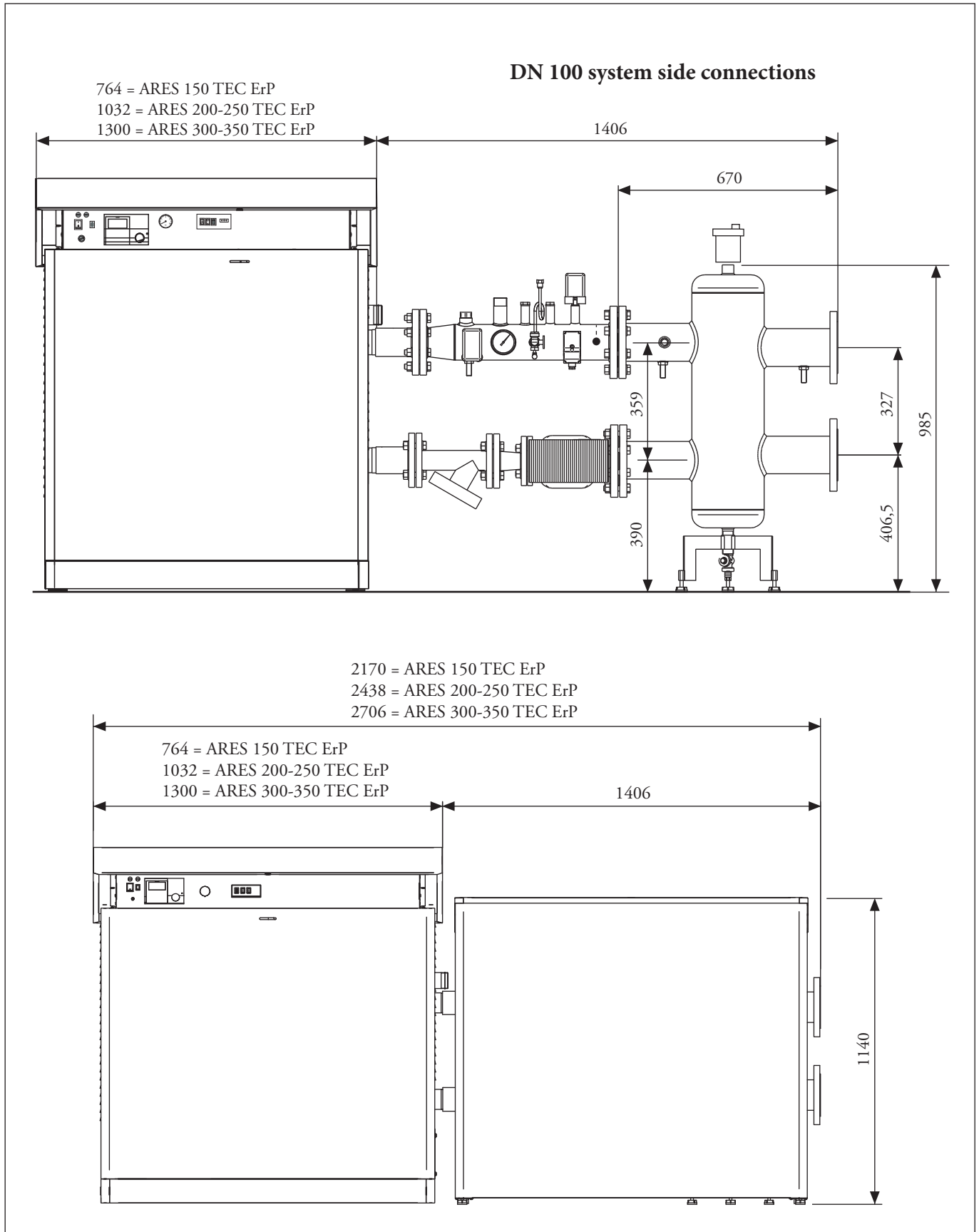

ARES 440 - 900 TEC ErP

18

**PRIMARY LOOP DIMENSIONS WITH HYDRAULIC SEPARATOR
(MODELS FROM 440 UP TO 900 kW)**

DN 100 system side connections

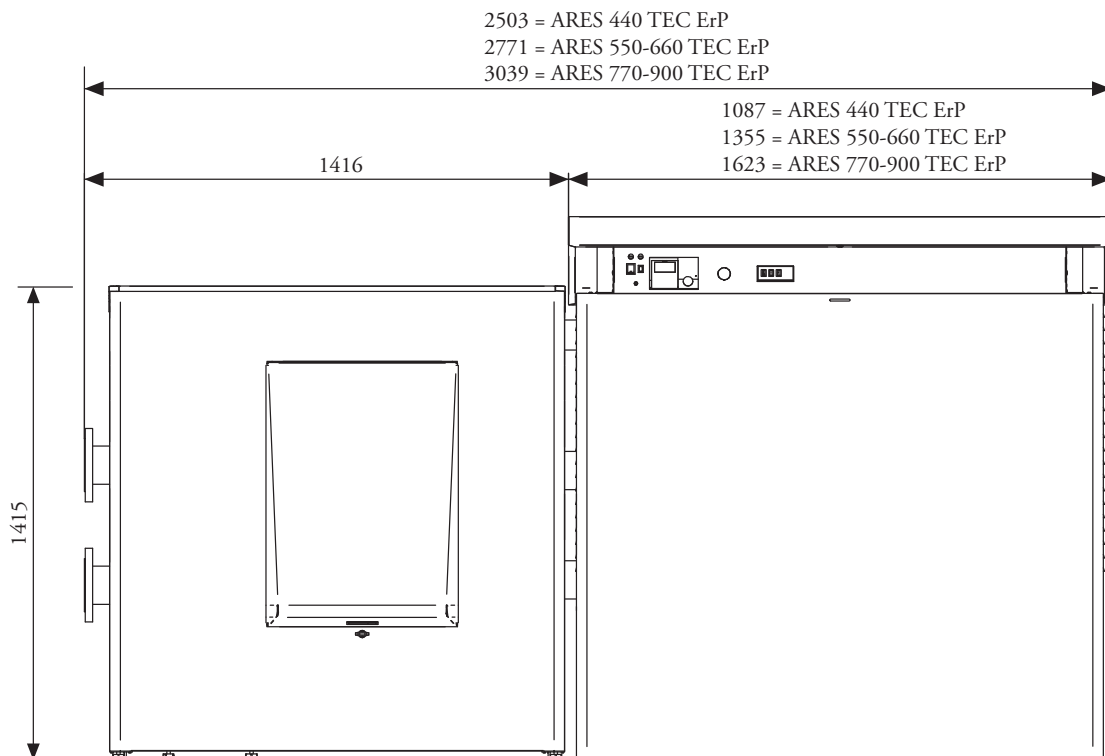
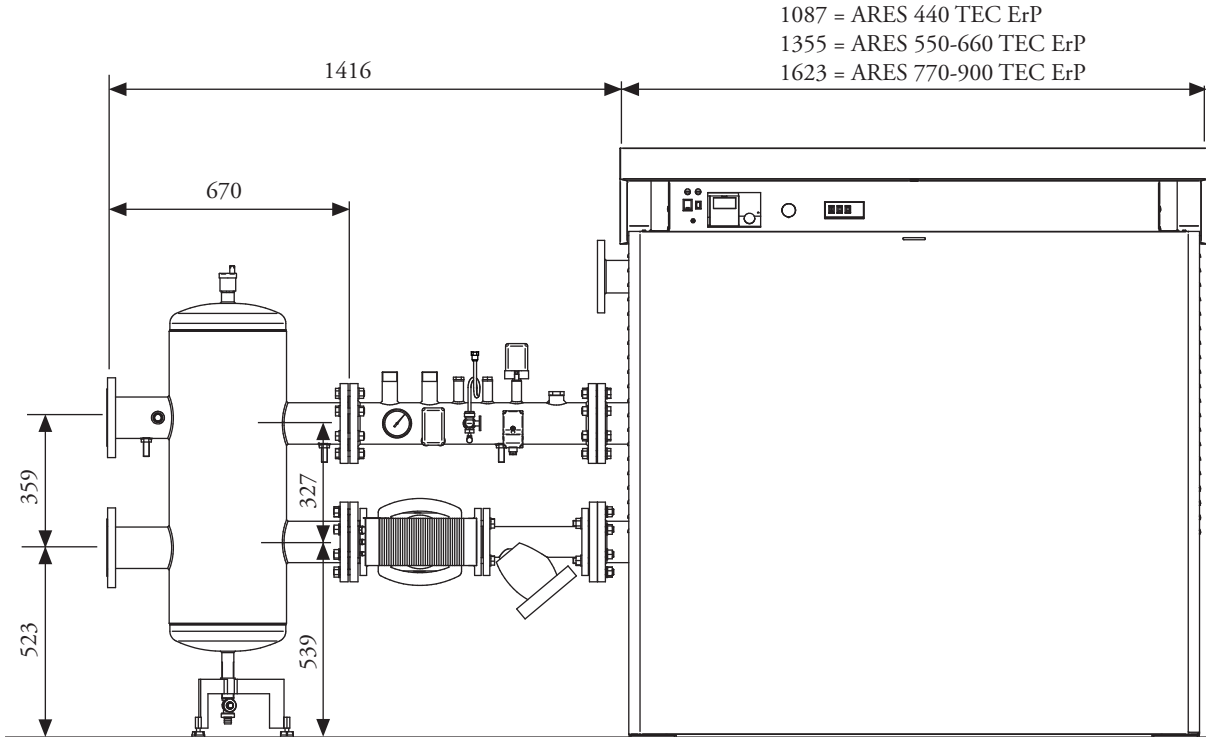

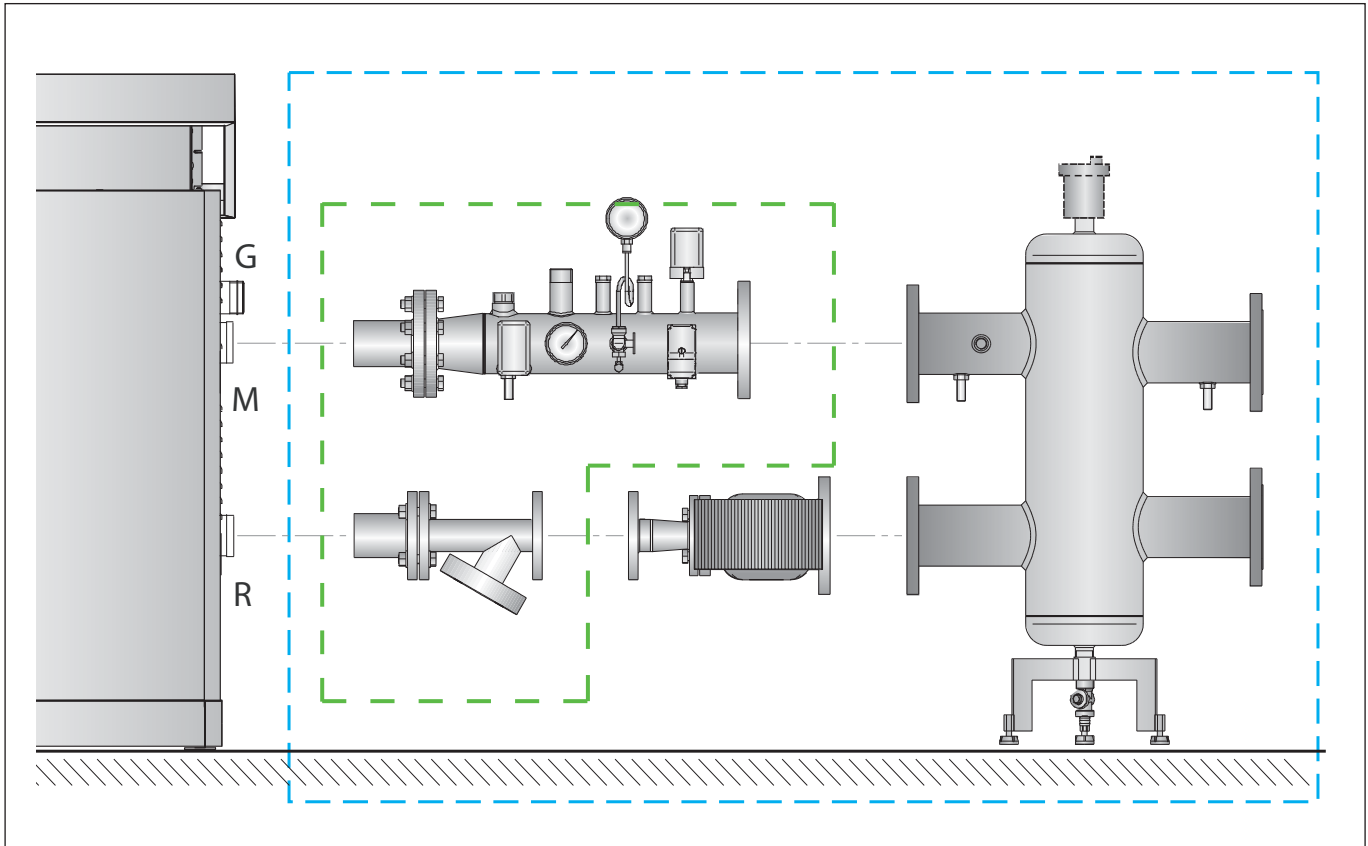

In addition to the INAIL safety kit complete with circulator pump and hydraulic separator including:

- INAIL safety kit complete and up-to-date to the R 2009 set;
- Y filter with DN 50 flanged connections (up to mod. 350), DN 65 (mod. from 440 to 770) and DN 100 (mod. 900);
- Modulating pump with low electrical consumption (class A);
- Hydraulic separator with DN 100 flanged connections.

Available in 5 different versions depending on the power of the generator, Immergas offers, if in the project, the professional wishes to size the pump independently or install a pump other than the modulating one provided in the complete kit:

- The single INAIL safety kit including return filter (available in three versions);
- the single hydraulic separator available in two versions based on the installed power.

INAIL safety kit including circulator pump and hydraulic separator	
INAIL safety kit including circulator pump and hydraulic separator for 150 kW code 3.023645	
INAIL safety kit including circulator pump and hydraulic separator for 200-250 kW code 3.023646	INAIL safety kit including circulator pump and hydraulic separator for 300-350 kW code 3.023647
INAIL safety kit including circulator pump and hydraulic separator for 440-770 kW code 3.023648	INAIL safety kit including circulator pump and hydraulic separator for 900 kW code 3.023649
INAIL safety kit with filter	
INAIL safety kit with filter for 150-350 kW code 3.023656	INAIL safety kit with filter for 440-770 kW code 3.023657
INAIL safety kit with filter for 900 kW code 3.023658	

ARES TEC ErP

20

HYDRAULIC SEPARATOR KIT

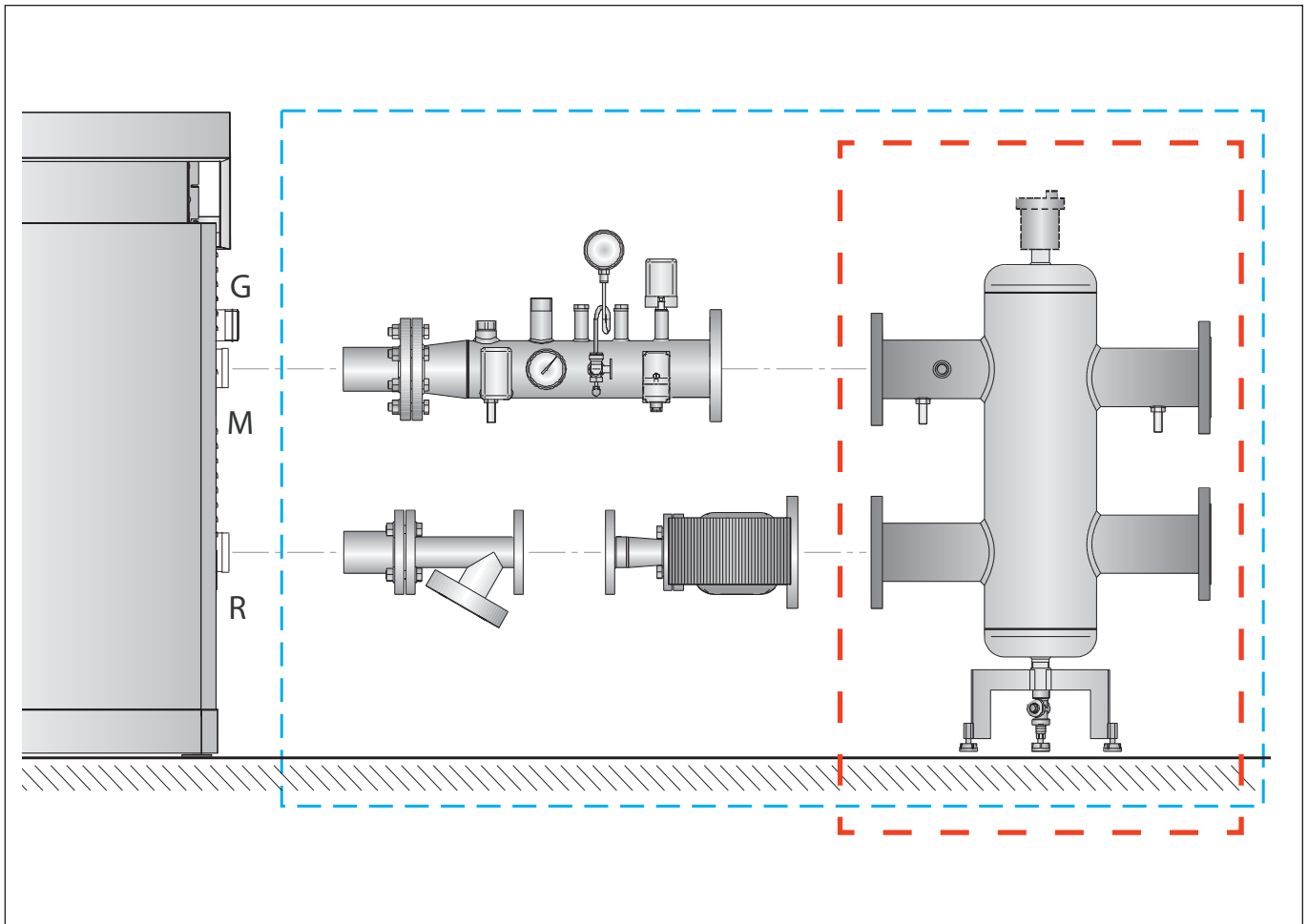

ARES TEC ErP is a low water content generator and therefore low inertia. The significant changes that follow on the system can be suitably balanced by the hydraulic separator which has 3 vital functions:

- 1) make the connected circuits independent (primary and secondary);
- 2) “sludge remover”, enabling circuit foreign matter to be collected;
- 3) “de-aerator”, to enable automatic air evacuation.

It is an open manifold which places system flow and return in communication, creating 2 circuits: a primary circuit (boiler -

manifold) and a secondary circuit (manifold-system) with DN 100 flanged connections.

The former circulates by the boiler pump, while the latter runs on the correct thermal gradient (and therefore the correct water flow rate), as defined by the system's design.

It is advisable to include a hydraulic manifold every time the overall flow rate required by the system is greater than what the boiler is able to supply (through the optional modulating circulator pump).

Hydraulic separator kit	
<p>Hydraulic separator kit for 150-350 kW code 3.023659</p>	<p>Hydraulic separator kit for 440-900 kW code 3.023660</p>

21 DIAGRAM FOR SELECTING THE CIRCULATION PUMP UP TO 350 kW

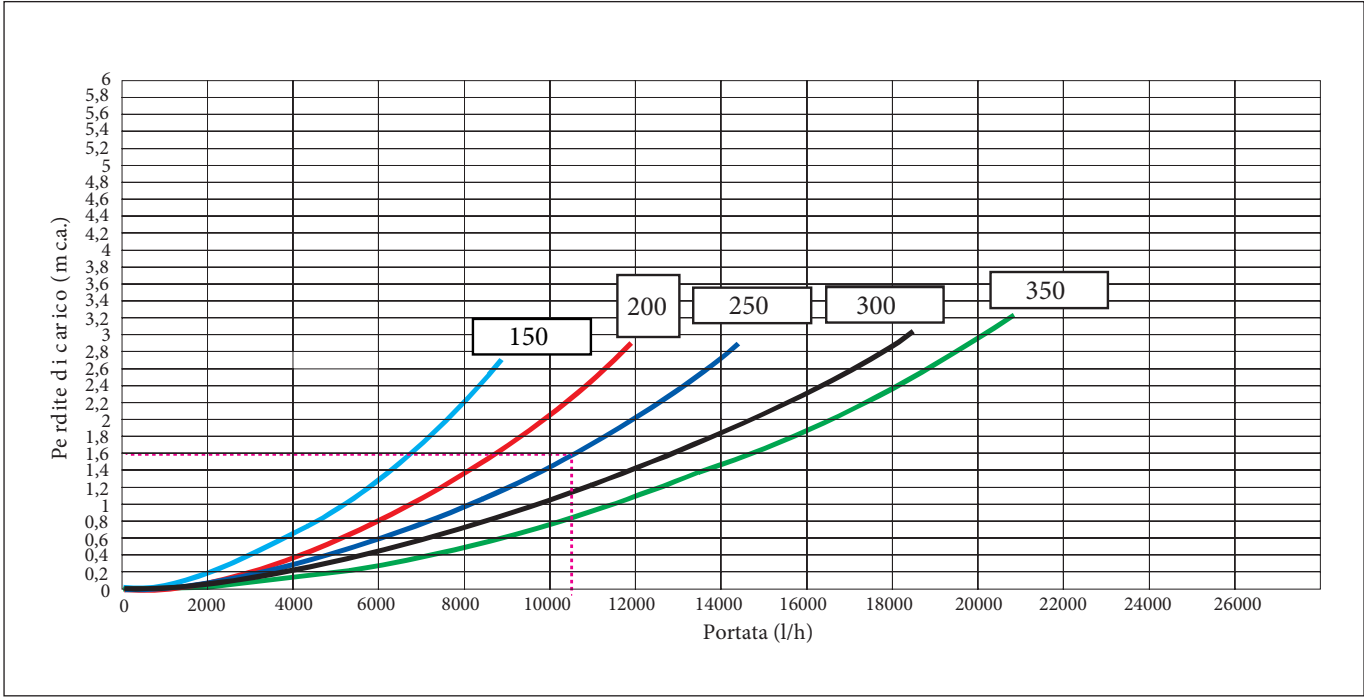

Power in kW	150	200	250	300	350
Flow rate in l/h (Δt = 15 K)	8376	11192	14018	16856	19712
Flow rate in l/h (Δt = 20 K)	6282	8394	10514	12642	14784

Immergas provides a series of primary loops complete with an accurately sized pump, if alternative solutions are being used, the boiler pump must have a head that is capable of ensuring the flow rates represented in the "Water side head losses" graph. The table above provides a guide of the flow rates of the circulator pump based on the Δt of the primary circuit if the installation is equipped with a hydraulic separator.

The pumps must be selected by the installer or designer based on the data for the boiler and system.
The pump is not an integral part of the boiler.
It is advisable to choose a circulator pump with a flow rate and head of approximately 2/3 of its typical curve.

EXAMPLE:
For a ΔT 20K, of an ARES 250 TEC ErP the maximum required flow rate is 10514 l/h.
From the boiler head loss graph it is possible to deduce that the circulator pump must ensure a head of at least 1.6 m/w.c.

NOTE: The hydraulic manifold inserted between the boiler and system circuits is always recommended.

ARES 440 - 900 TEC ErP

21.1 DIAGRAM FOR SELECTING THE CIRCULATION PUMP FROM 440 UP TO 900 kW

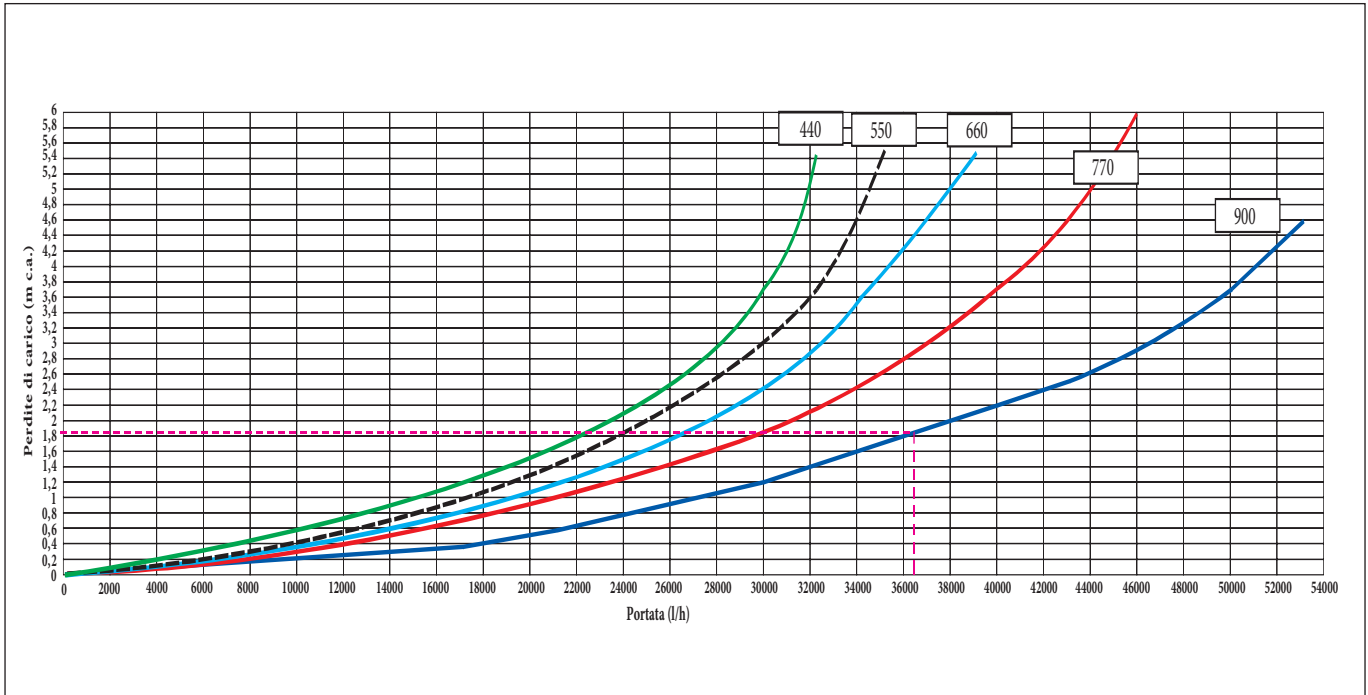

Power in kW	440	550	660	770	900
Flow rate in l/h ($\Delta t = 15$ K)	24326	30404	36487	42570	48647
Flow rate in l/h ($\Delta t = 20$ K)	18243	22804	27365	31926	36487

Immergas provides a series of primary loops complete with an accurately sized pump, if alternative solutions are being used, the boiler pump must have a head that is capable of ensuring the flow rates represented in the "Water side head losses" graph.

The table above provides a guide of the flow rates of the circulator pump based on the Δt of the primary circuit if the installation is equipped with a hydraulic separator.

The pumps must be selected by the installer or designer based on the data for the boiler and system.

The pump is not an integral part of the boiler.

It is advisable to choose a circulator pump with a flow rate and head of approximately 2/3 of its typical curve.

EXAMPLE:

For a ΔT 20K, of an ARES 900 TEC ErP the maximum required flow rate is 36487 l/h.

From the boiler head loss graph it is possible to deduce that the circulator pump must ensure a head of at least 1.8 m/w.c.

NOTE: The hydraulic manifold inserted between the boiler and system circuits is always recommended.

**INAIL safety kit and complete hydraulic separator for 150-350 kW
(3 codes available)**

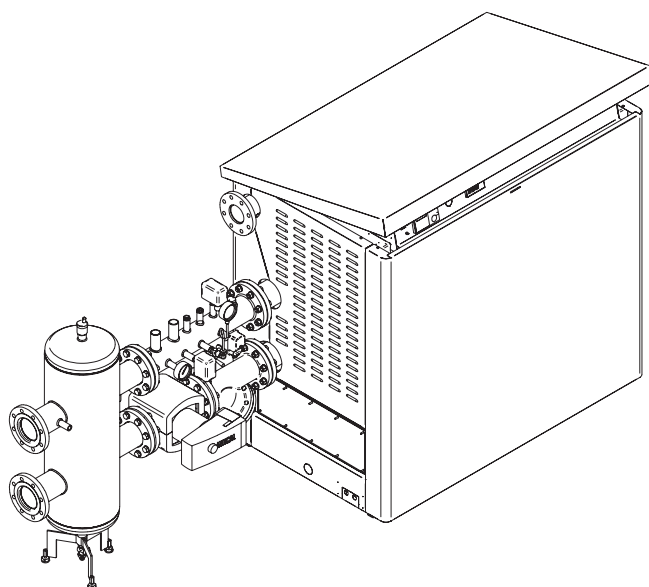
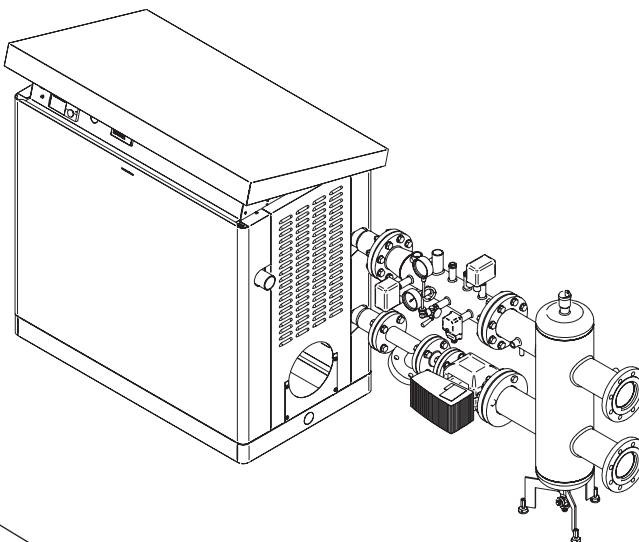

**INAIL safety kit and complete hydraulic separator for 440-900 kW
(2 codes available)**

Hydraulic Kits	
INAIL safety kit including circulator pump and hydraulic separator for 150 kW code 3.023645	
INAIL safety kit including circulator pump and hydraulic separator for 200-250 kW code 3.023646	INAIL safety kit including circulator pump and hydraulic separator for 300-350 kW code 3.023647
INAIL safety kit including circulator pump and hydraulic separator for 440-770 kW code 3.023648	INAIL safety kit including circulator pump and hydraulic separator for 900 kW code 3.023649

ARES TEC ErP

23

EXTERNAL COVERING KIT FOR INAIL SAFETY AND SEPARATOR COMPLETE HYDRAULIC

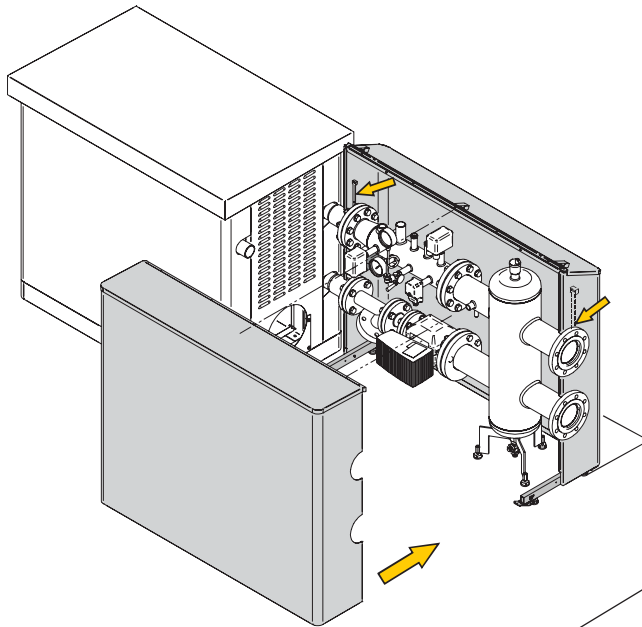

External covering kit for INAIL safety kit and complete hydraulic separator for 150-350 kW

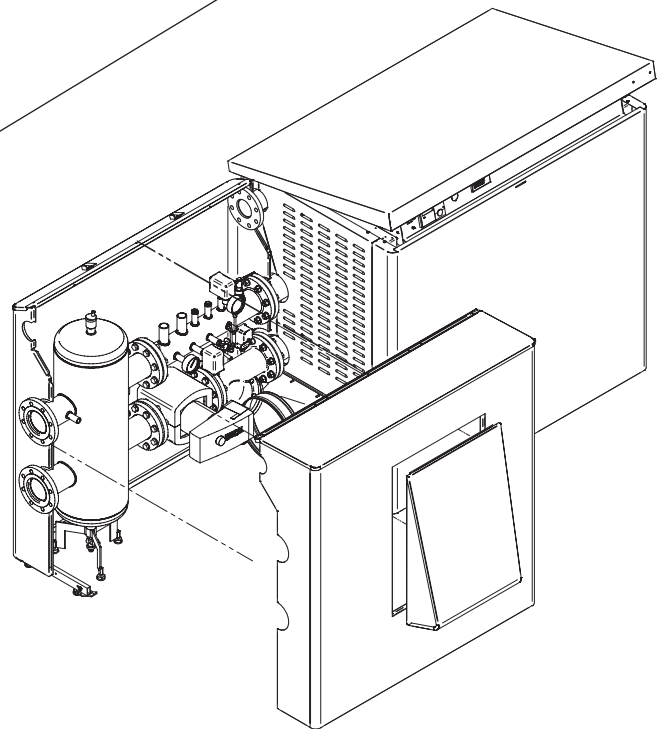

External covering kit for INAIL safety kit and complete hydraulic separator for 440-900 kW

External covering kit

External covering kit for INAIL kit and hydraulic separator of 150-350 kW
code 3.023670

External covering kit for INAIL kit and hydraulic separator of 440-900 kW
code 3.023671

24 INAIL SAFETY KIT INCLUDING CIRCULATOR PUMP AND PLATE HEAT EXCHANGER (MODELS UP TO 350 kW)

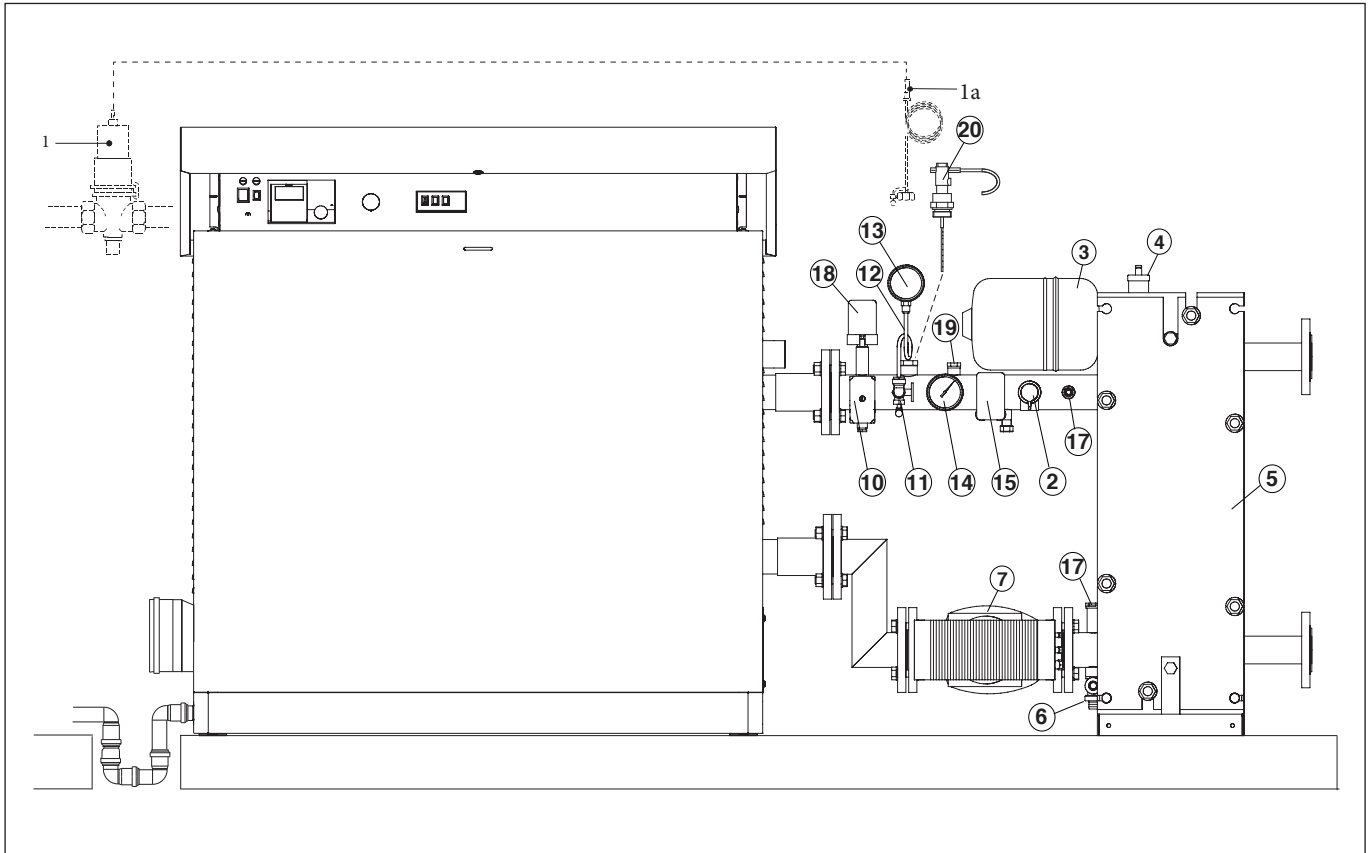

As an alternative to the primary loops with hydraulic separator, Immergas also offers a choice of primary loops with plate heat exchanger with the following advantages:

- physical circuit separation, there is no hydraulic circulation between primary boiler circuit and system/load secondary circuit;
- option to have different pressures between primary and secondary (e.g. boiler vessel closed, system vessel open).
- boiler installation on obsolete systems with potential risks of dirt or system leaks, with consequent top ups;
- in case of external installation, option of limiting the quantity of antifreeze glycol to be added.

Safety devices:

- 1) Fuel shut-off valve - NOT INCLUDED
 - 2) Safety valve set at 5 Bar
- Visible draining funnel - NOT INCLUDED

Attention: it is forbidden to interpose any type of interception between the boiler and the safety valve.

Protection devices:

- 10) Safety thermostat (immovable calibration < 100°C)
- 15) Minimum pressure switch (can be calibrated at 0.5-1.7 bar)
- 18) Safety pressure switch (can be calibrated at 1-5 bar)

Control devices:

- 13) Pressure gauge with (12) damper pipe and (11) G $\frac{1}{2}$ " pressure gauge-holder tap
- 14) G $\frac{1}{2}$ " Thermometer (max 120°C full scale)
- 17) G $\frac{1}{2}$ " inspection sample point
- 19) Supplementary G $\frac{1}{2}$ " connection stub pipe for potential (V.I.C.)
- 20) Flow switch in case water flow is interrupted
- 3) 8 litre expansion vessel (150-350 kW)

Other components:

- 7) Modulating pump with low electrical consumption (class A) type: Wilo STRATOS 40/1-4 (mod. from 150 to 200) / Wilo STRATOS 65/1-12 (mod. from 250 to 350)
 - 5) Stainless steel plate heat exchanger
 - 4) Automatic air vent valve
 - 6) G $\frac{3}{4}$ " draining valve
- Flanges/adaptors and various fittings
Support base
Flow/return pipes with DN 50 flanged connections

ARES 440 - 900 TEC ErP

25 INAIL SAFETY KIT INCLUDING CIRCULATOR PUMP AND PLATE HEAT EXCHANGER (MODELS FROM 440 UP TO 900 kW)

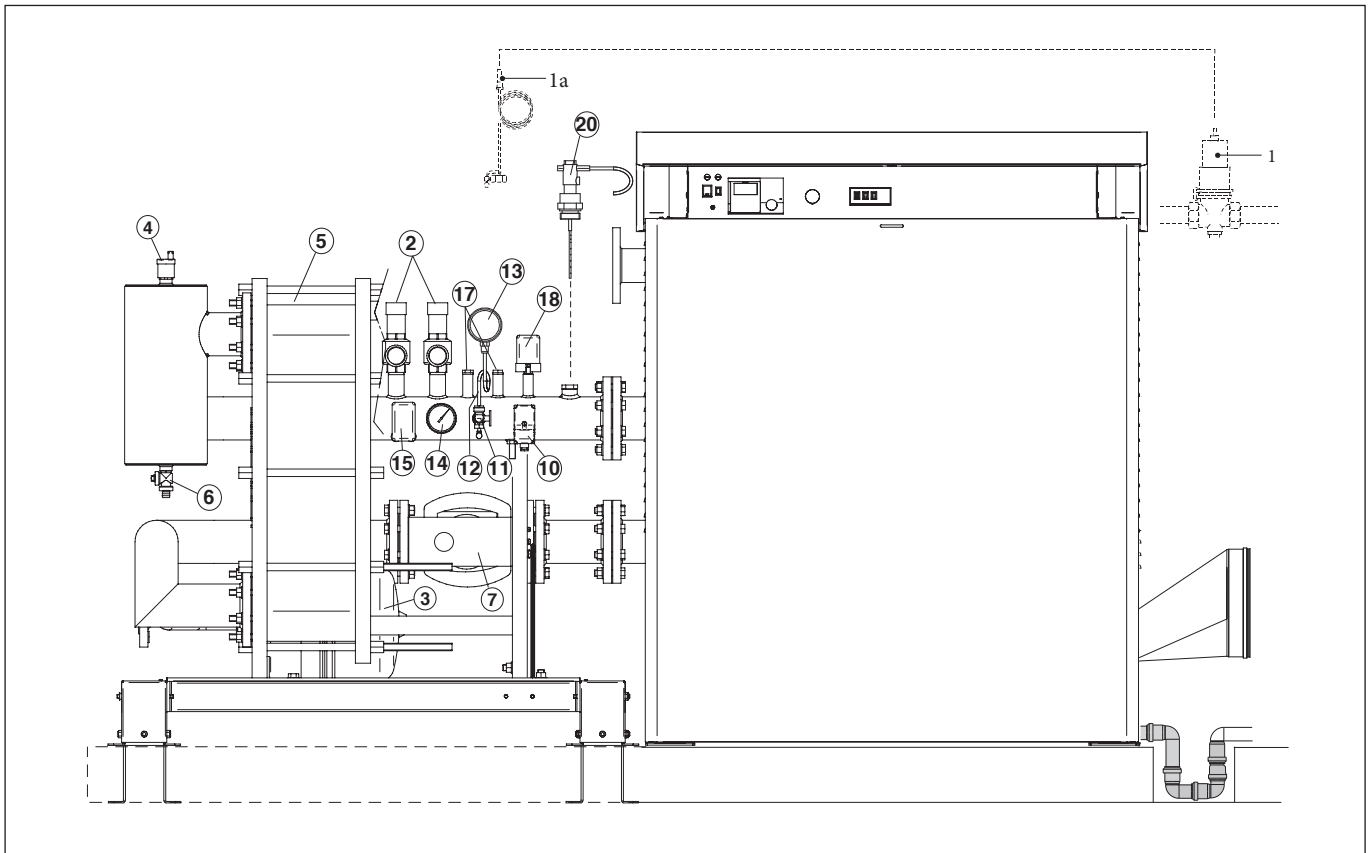

As an alternative to the primary loops with hydraulic separator, Immergas also offers a choice of primary loops with plate heat exchanger with the following advantages.

- physical circuit separation, there is no hydraulic circulation between primary boiler circuit and system/load secondary circuit;
- option to have different pressures between primary and secondary (e.g. boiler vessel closed, system vessel open).
- boiler installation on obsolete systems with potential risks of dirt or system leaks, with consequent top ups;
- in case of external installation, option of limiting the quantity of antifreeze glycol to be added.

Safety devices:

- 1) Fuel shut-off valve - NOT INCLUDED
- 2) Safety valve set at 5 bar (there are 2 safety valves for the models 660-770-900)

Visible draining funnel - NOT INCLUDED

Attention: it is forbidden to interpose any type of interception between the boiler and the safety valve (or 2 for models 660-770-900).

Protection devices:

- 10) Safety thermostat (immovable calibration < 100°C)
- 15) Minimum pressure switch (can be calibrated at 0.5-1.7 bar)
- 18) Safety pressure switch (can be calibrated at 1-5 bar)

Control devices:

- 13) Pressure gauge with (12) damper pipe and (11) G $\frac{1}{2}$ " pressure gauge-holder tap
- 14) G $\frac{1}{2}$ " Thermometer (max 120°C full scale)
- 17) G $\frac{1}{2}$ " connection sample points for potential (V.I.C.)
- 20) Flow switch in case water flow is interrupted
- 3) 24 litre expansion vessel (440-900 kW)

Other components:

- 7) Modulating pump with low electrical consumption (class A) type: Wilo STRATOS 65/1-12 (mod. from 440 to 550) / Wilo STRATOS 100/1-12 (mod. from 660 to 900)
 - 5) Stainless steel plate heat exchanger
 - 4) Automatic air vent valve
 - 6) G $\frac{3}{4}$ " draining valve
- Flanges/adaptors and various fittings
Support base
Flow/return pipes with DN 100 flanged connections

ARES 150 - 350 TEC ErP

26

DIMENSIONS WITH PRIMARY LOOP WITH PLATE HEAT EXCHANGER (MODELS UP TO 350 kW)

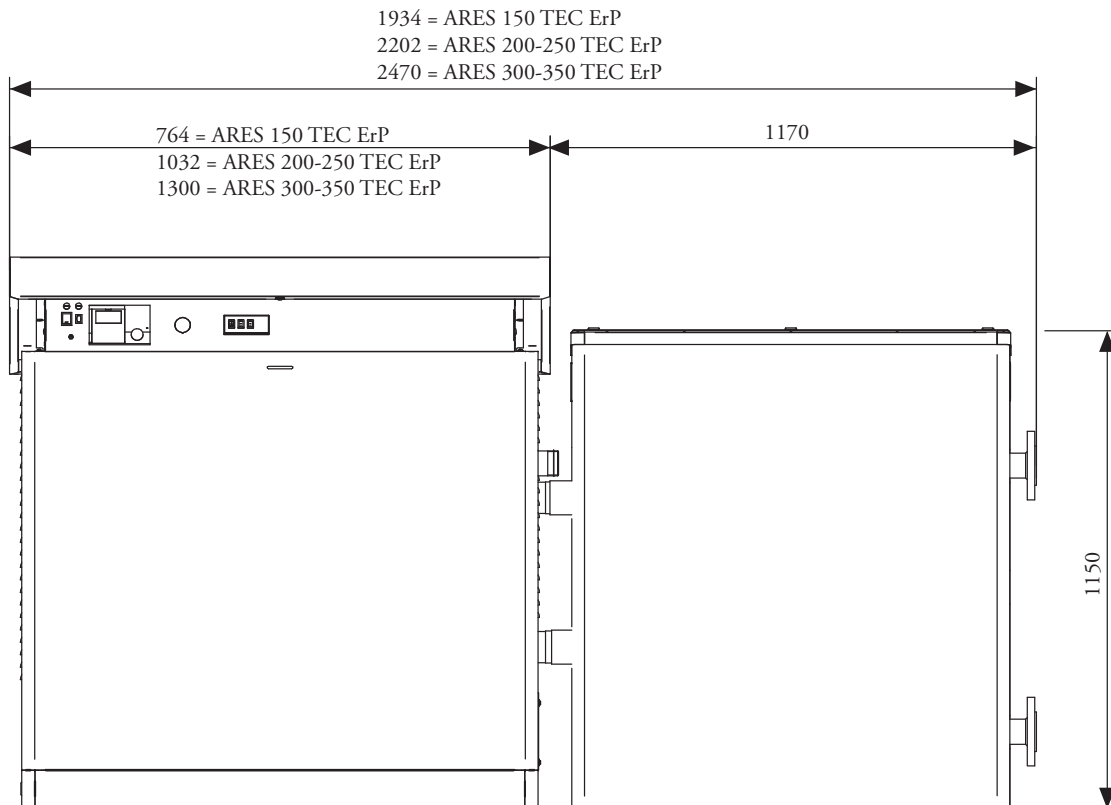
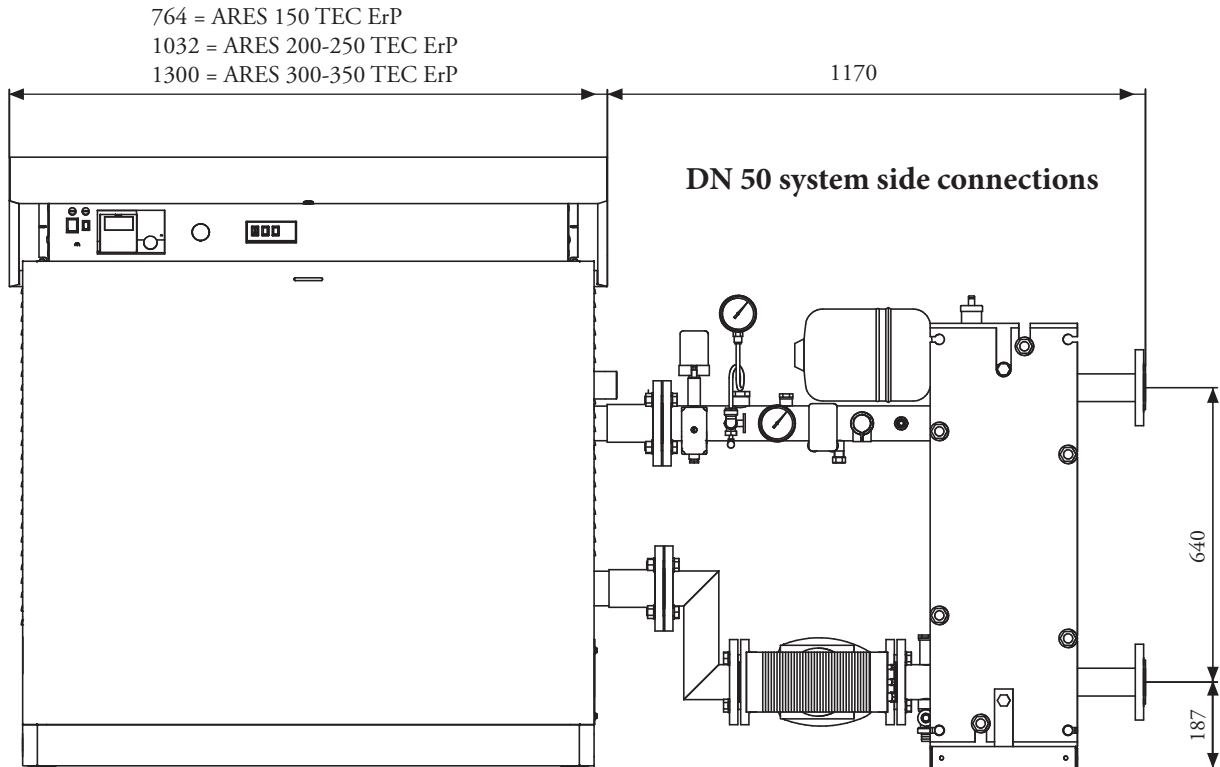

ARES 440 - 900 TEC ErP

27

DIMENSIONS WITH PRIMARY LOOP WITH PLATE HEAT EXCHANGER (MODELS FROM 440 UP TO 900 kW)

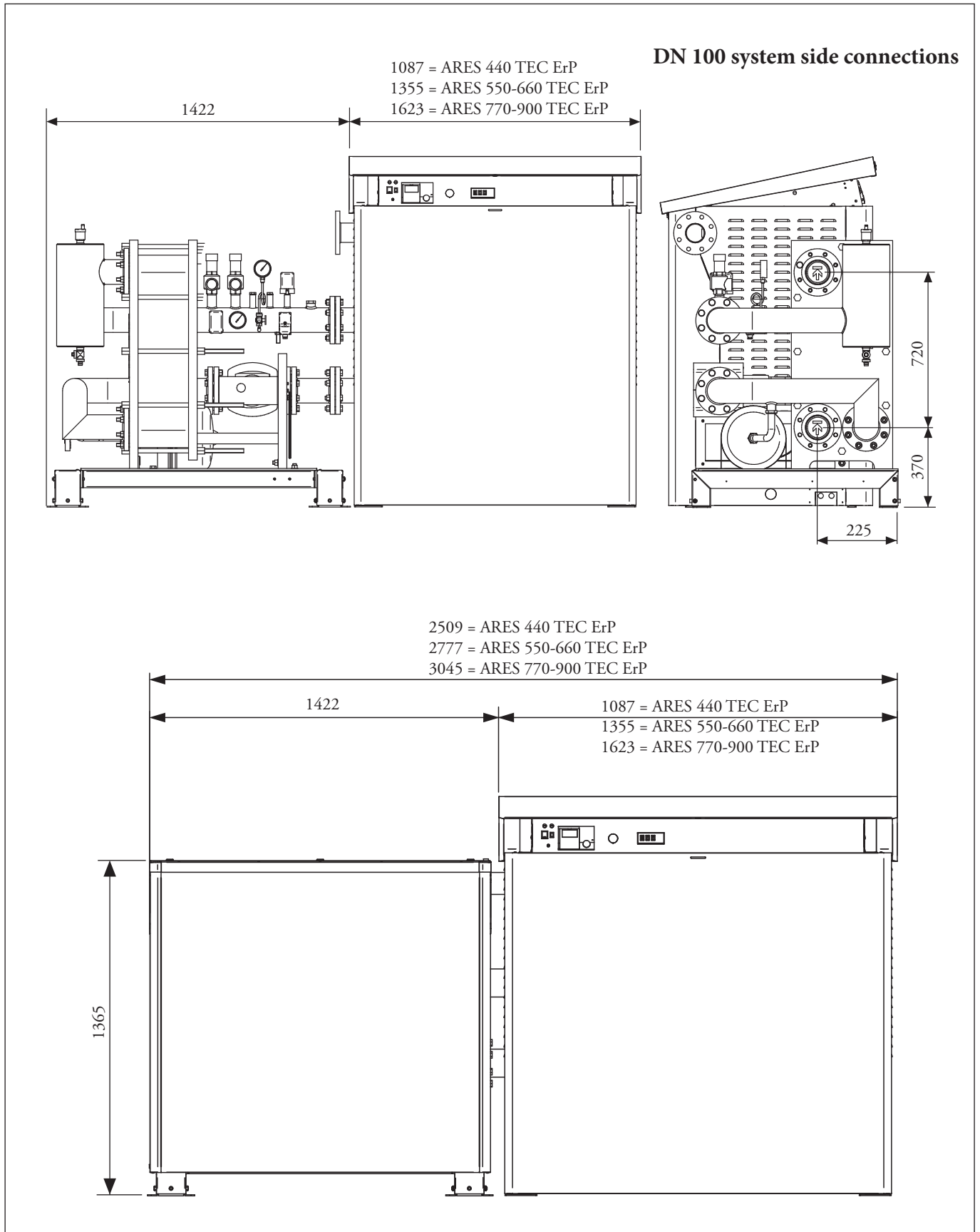

INAIL safety kit and complete plate heat exchanger for 150-350 kW (2 codes available)

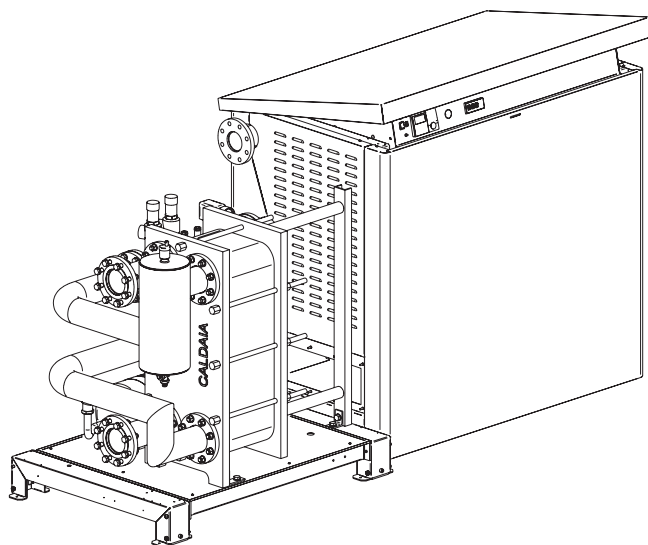
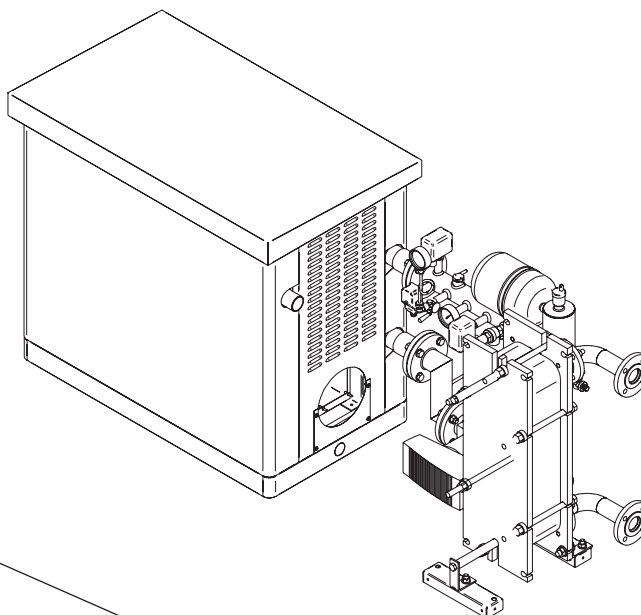

INAIL safety kit and complete plate heat exchanger for 440-900 kW (No. 4 codes available)

Hydraulic Kits	
<p>INAIL safety kit including circulator pump and plate heat exchanger for 150-200 kW code 3.023650</p>	<p>INAIL safety kit including circulator pump and plate heat exchanger for 250-350 kW code 3.023651</p>
<p>INAIL safety kit including circulator pump and plate heat exchanger for 440-550 kW code 3.023652</p>	<p>INAIL safety kit including circulator pump and plate heat exchanger for 660 kW code 3.023653</p>
<p>INAIL safety kit including circulator pump and plate heat exchanger for 770 kW code 3.023654</p>	<p>INAIL safety kit including circulator pump and plate heat exchanger for 900 kW code 3.023655</p>

ARES TEC ErP

29

EXTERNAL COVERING KIT FOR INAIL SAFETY AND COMPLETE PLATE HEAT EXCHANGER

External covering kit for INAIL safety kit and complete plate heat exchanger for 150-350 kW

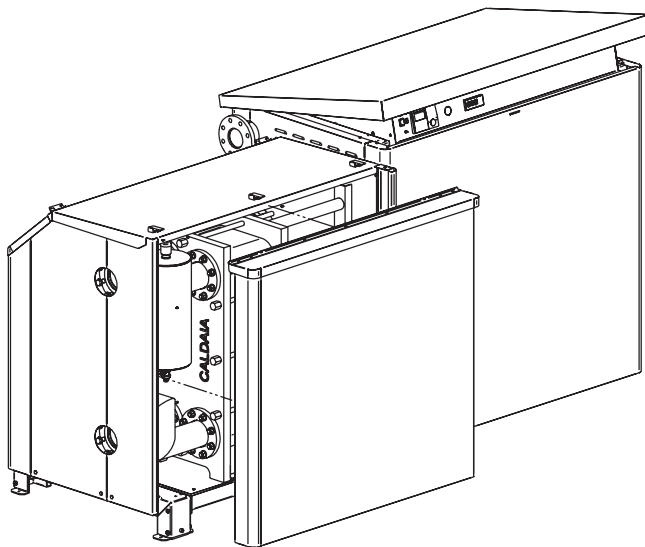
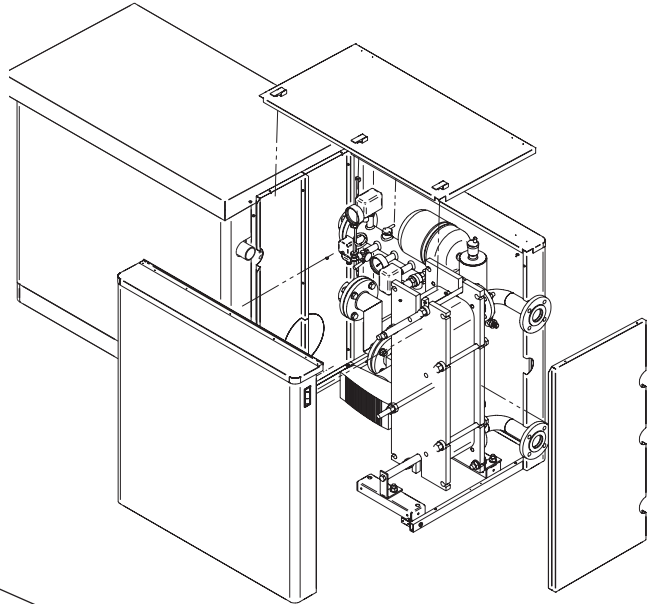

External covering kit for INAIL safety kit and complete plate heat exchanger for 440-900 kW

External covering kit

External covering for INAIL kit and plate heat exchanger of 150-350 kW
code 3.023672

External covering for INAIL kit and plate heat exchanger of 440-900 kW
code 3.023673

Plate heat exchanger coupled with ARES TEC ErP	Number of plates	Maximum managed power (kW)	Primary Flow rate (m ³ /h) M/R 80°/65°	Secondary Flow rate (m ³ /h) M/R 70°/60°	Δp (m w.c.)		Weight (kg) heat exchanger only
					Primary circuit Δt 15°C	Secondary circuit Δt 10°C	
150	32	200	8.62	12.93	1.0	2.0	149.22
200	32	200	11.49	17.24	1.7	3.4	149.22
250	50	350	14.37	21.55	1.4	2.9	167.75
300	50	350	17.24	25.86	2.0	4.1	167.75
350	50	350	20.11	30.17	2.6	5.5	167.75
440	77	550	25.29	37.93	0.5	1.0	405.8
550	77	550	31.61	47.41	0.8	1.6	405.8
660	77	660	37.93	56.90	1.1	2.5	405.8
770	104	770	44.25	66.38	0.9	1.9	451.98
900	104	900	51.72	77.59	1.3	2.4	451.98

ARES TEC ErP

31 ELECTRICAL CONNECTIONS AND CONTROL UNIT DESCRIPTION FOR ARES TEC ErP

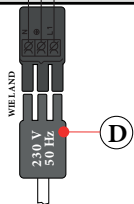
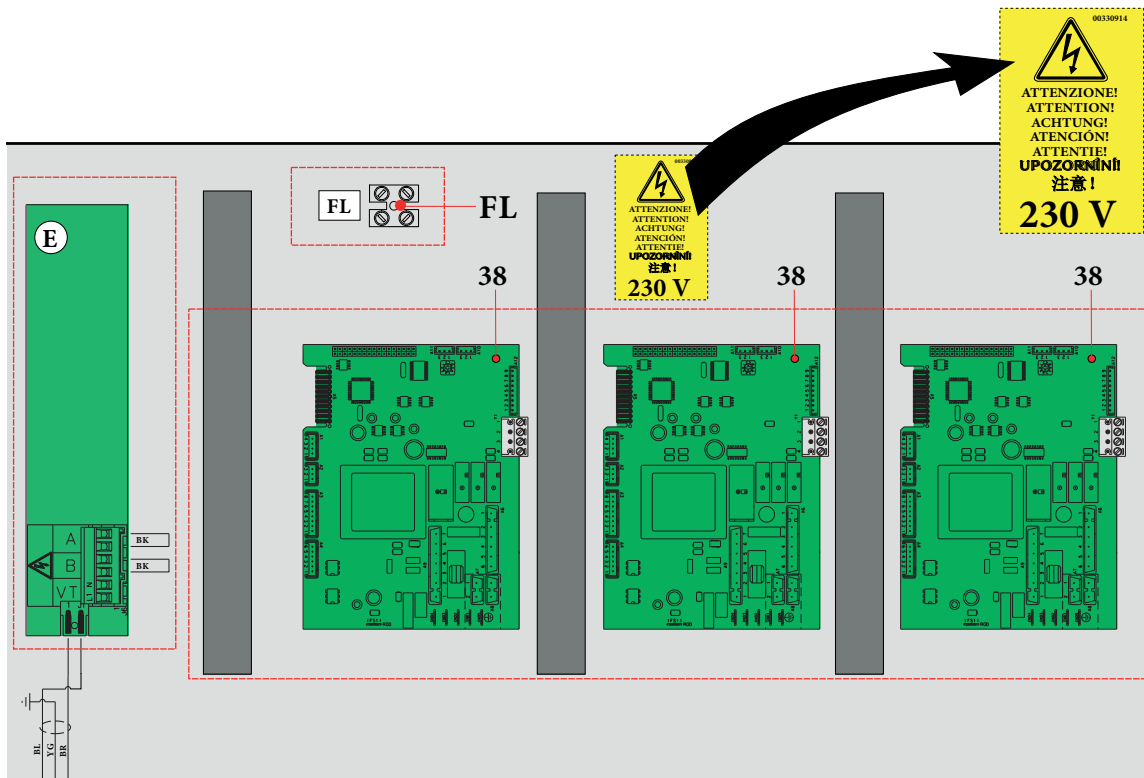
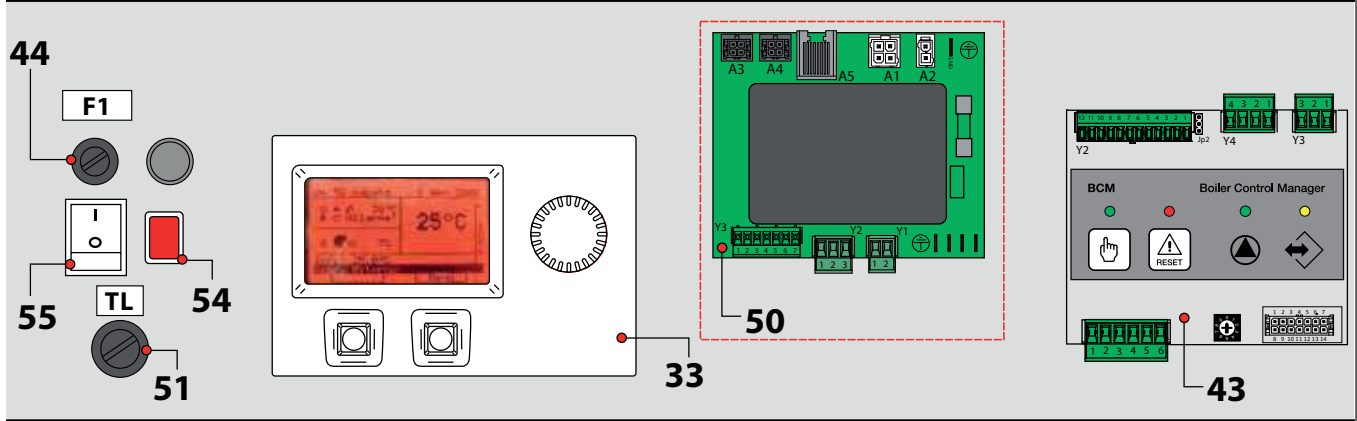

KEY	
No.	Description
33	Temperature control HSCP
38	BMM Burner management board
43	BCM Boiler controller
44	F1 Fuse power supply 6.3 A
50	Power supply board

51	TLG	Manual resetting general limit thermostat (model 350)
54	LTGL	TLG intervention light (model 350)
55		Main boiler switch
E		Power supply distribution board
FL		Connection for flow switch
D		Wieland power plug 230V - 50Hz

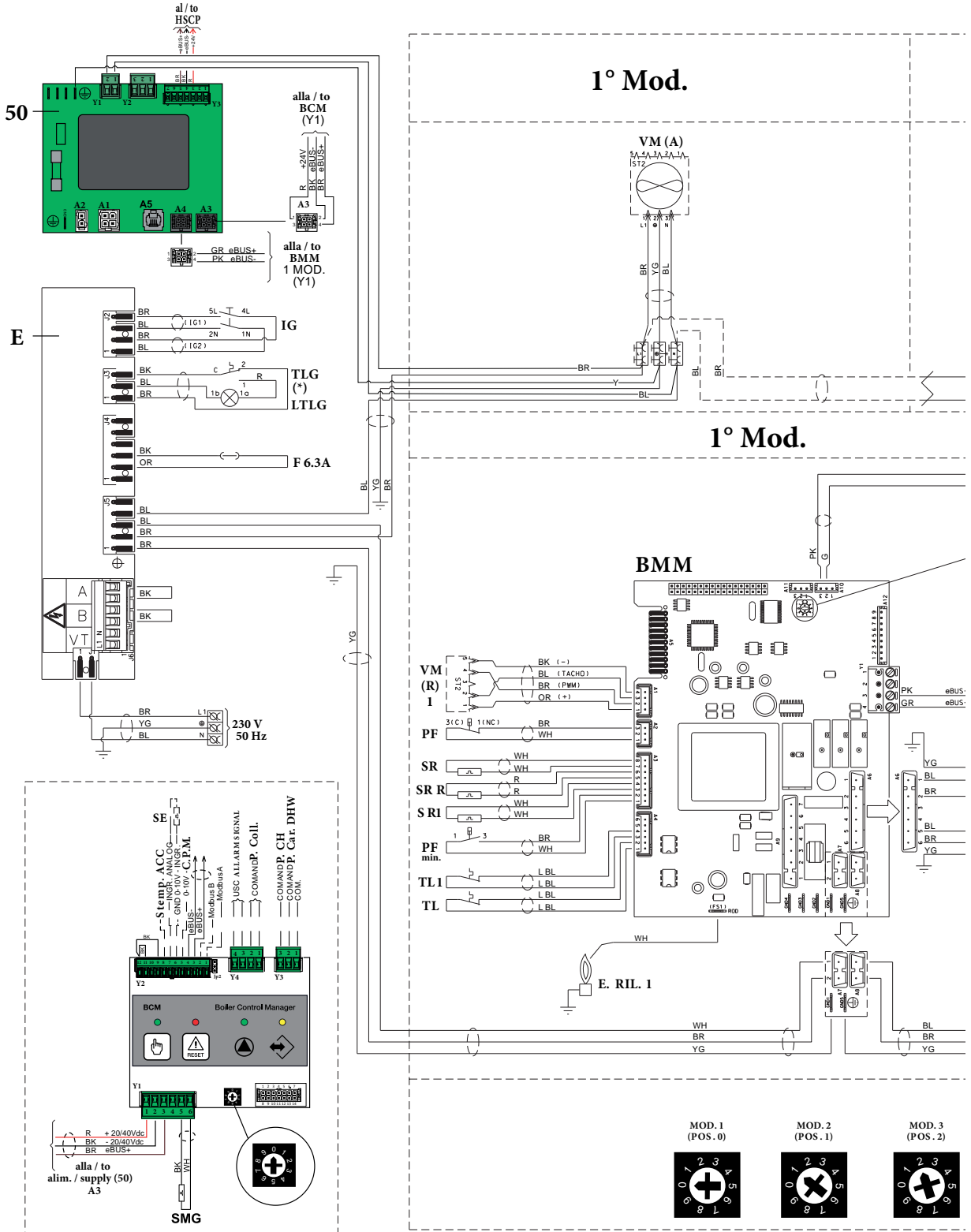

Common Key	
IG	Main switch
TLG	General limit thermostat
LTLG	General limit thermostat light
F	Fuse
HSCP	Temperature control

BMM Board Key (for each module)	
IGN. E.	Ignition electrode
DET. E.	Detection electrode
SR	Heating sensor (only 1st mod.)
SR 1-7	Local heating sensor
PF	Flue pressure switch (only 1st mod.)

PF min	Minimum Flue pressure switch (only 1st mod.)
SL	Condensate level sensor (2nd mod.)
IGN. T.	Ignition Transformation
TL	Limit thermostat
TL 1-7	Local limit thermostat

ARES 150 - 350 TEC ErP

Intermediate and Last Module

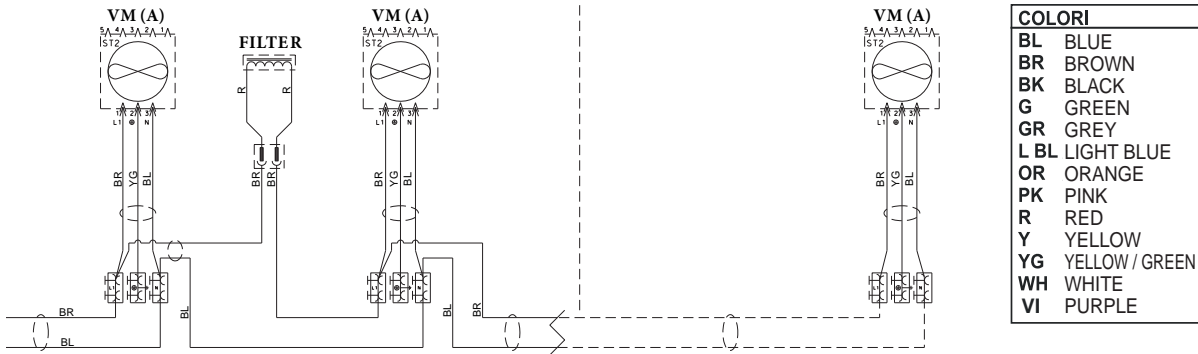

2° - 7° Mod.

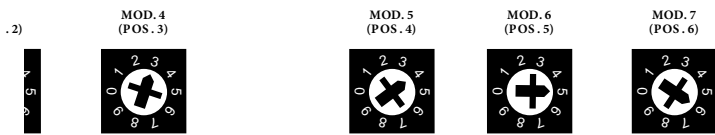
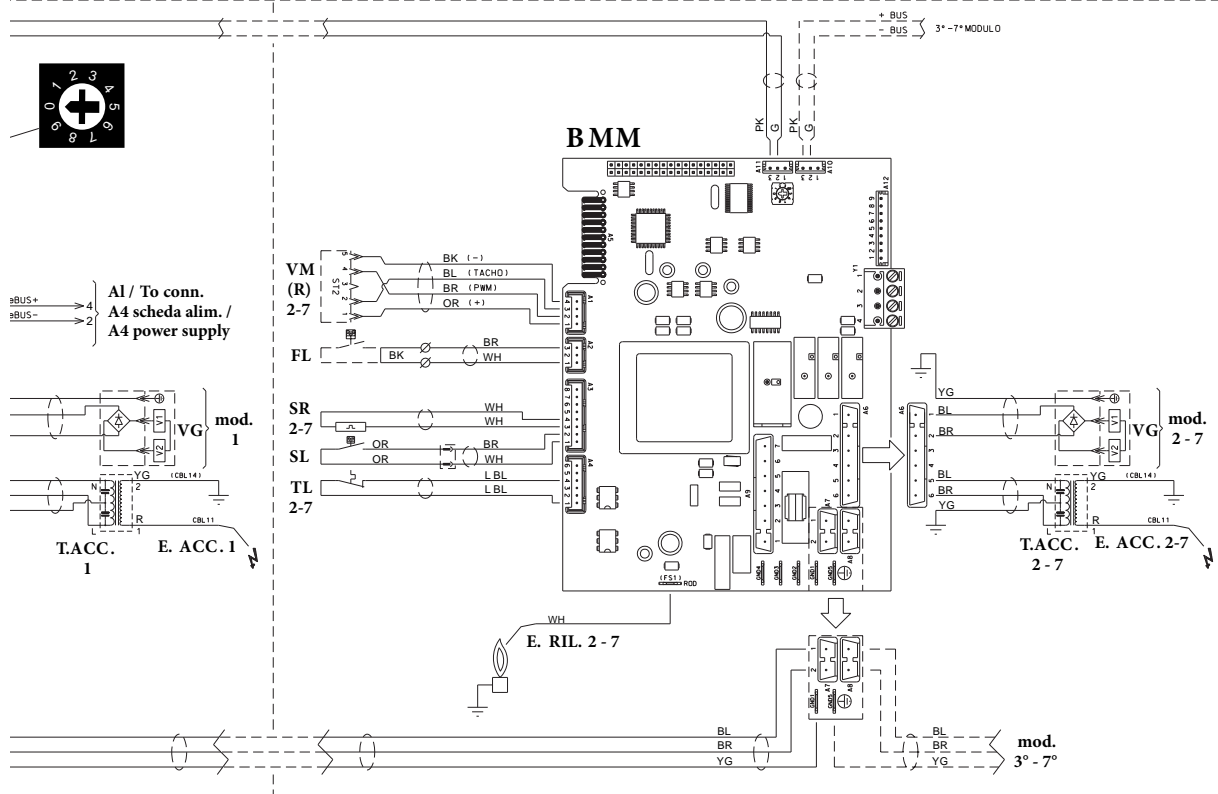

VG	Gas valve
VM (A)	Modulating fan power supply
VM (R)	Modulating fan adjustment/ Det.
SRR	Global return sensor
BCM board Key	
SMG	Global flow probe

IGN. temp. p.	Storage tank temperature sensor
SE	Outdoor temperature sensor
ANALOG. IN.	Analogue input
GND 0-10V ING	0-10 V analogue input
0-10V C.P.M.	Modulating Pump Control
ALARM SIGNAL	Alarm Outlet

Manif. P. Ctrl.	Boiler manifold pump control
C.H. P. Ctrl.	Central heating pump control
P. car DHW	Storage tank load pump control

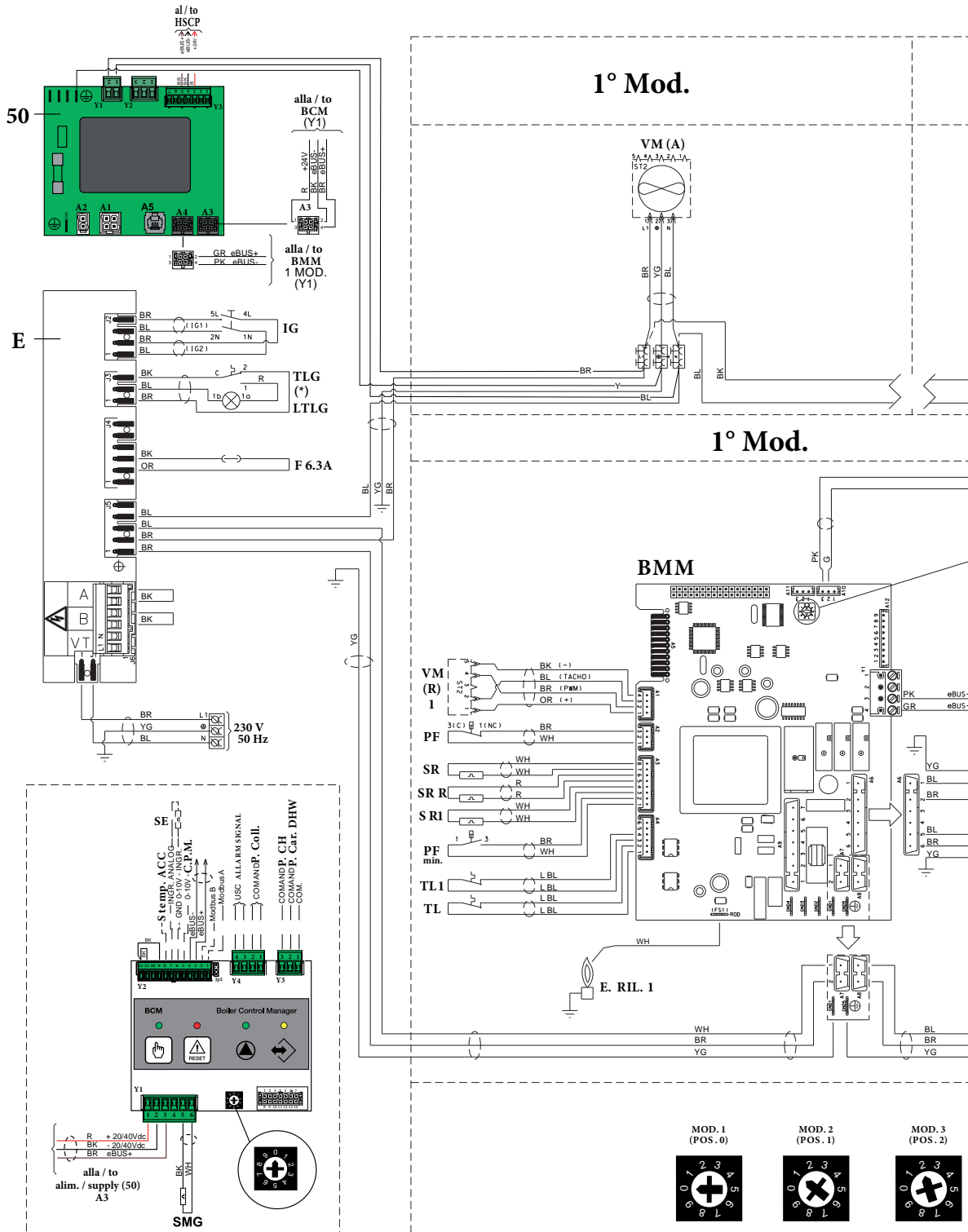

Common Key	
IG	Main switch
TLG	General limit thermostat
LTLG	General limit thermostat light
F	Fuse
HSCP	Temperature control
BMM Board Key (for each module)	

IGN. E.	Ignition electrode
DET. E.	Detection electrode
SR	Heating sensor (only 1st mod.)
SR 1-8	Local heating sensor
PF	Flue pressure switch (only 1st mod.)
PF min	Minimum Flue pressure switch (only 1st mod.)
SL	Condensate level sensor (2nd mod.)

IGN. T.	Ignition Transformation
TL	Limit thermostat
TL 1-8	Local limit thermostat
VG	Gas valve
VM (A)	Modulating fan power supply
VM (R)	Modulating fan adjustment/Det.
SRR	Global return sensor

ARES 440 - 900 TEC ErP

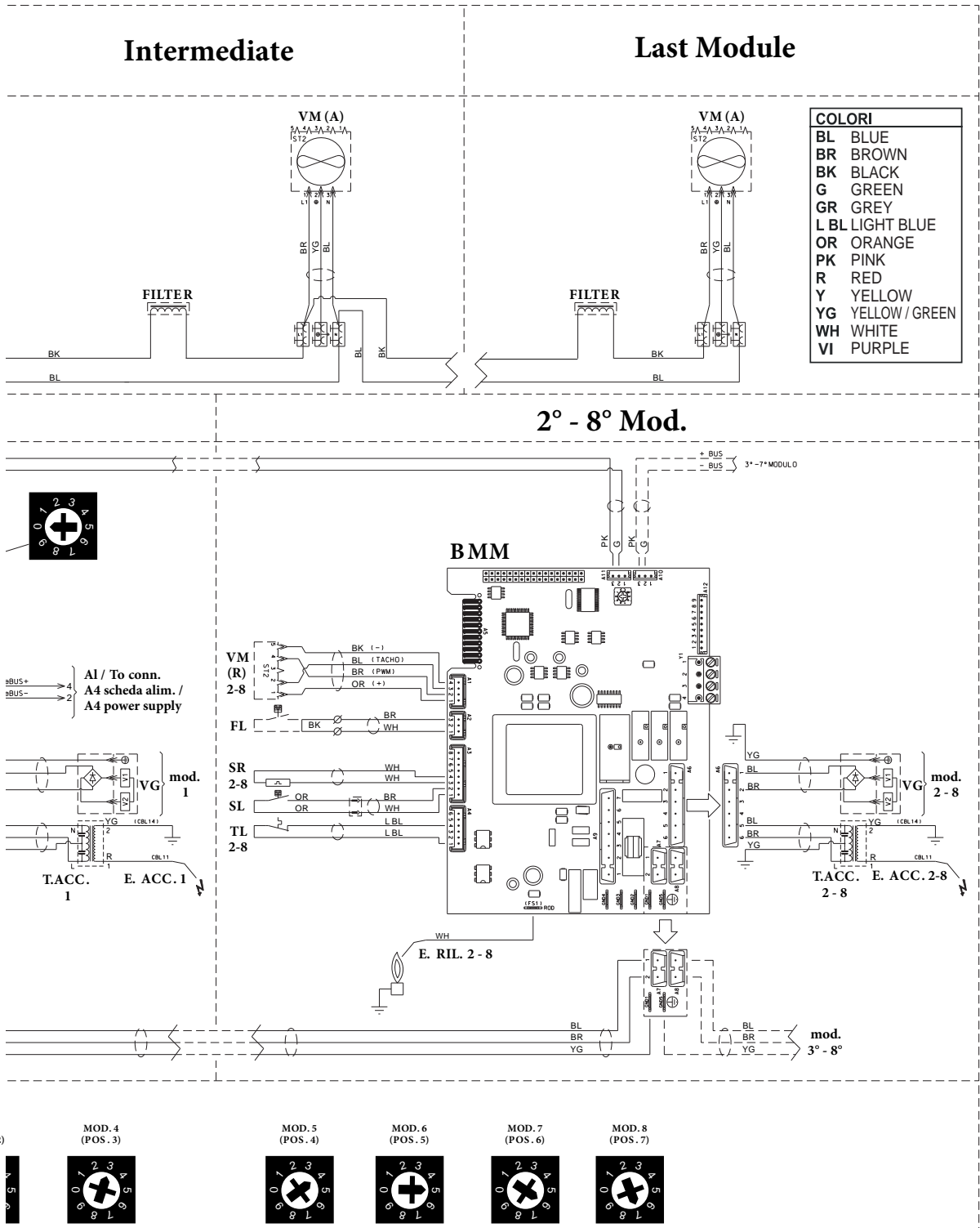

			ARES 150 TEC ErP	ARES 200 TEC ErP
Maximum nominal heat input		kW (kcal/h)	150 (129.000)	200 (172.000)
Maximum useful heat output (80/60°C)		kW (kcal/h)	146.1 (125.646)	195.2 (167.872)
Maximum useful heat output (50/30°C)		kW (kcal/h)	150 (129.000)	200.4 (172.344)
Minimum nominal heat input		kW (kcal/h)	12 (10.356)	12 (10.356)
Minimum nominal heat output (80/60°C)		kW (kcal/h)	11.7 (10.062)	11.7 (10.062)
Minimum nominal heat output (50/30°C)		kW (kcal/h)	12.8 (11.008)	12.8 (11.008)
Efficiency at 100% Pn (80/60°C)		%	97.4	97.6
Efficiency at 30% of the load (80/60°C)		%	95.5	95.9
Efficiency at 100% Pn (50/30°C)		%	100.0	100.2
Efficiency at 30% of the load (T. r. 30°C)		%	107.3	107.3
Central heating circuit				
Central heating system adjustable temperature		°C	25-85	25-85
System max. working temperature		°C	90	90
System max. working pressure		bar	6.0	6.0
System min. working pressure		bar	0.5	0.5
Water flow rate at nom. power (ΔT 20° C)		l/h	6.282	8.394
Gas supply				
METHANE fan speed (G20)	MIN - MAX	No. revs	1860 - 5880	1860 - 5880
LPG fan speed (G31)	MIN - MAX	No. revs	1800 - 5460	1800 - 5460
Gas flow rate at METHANE burner (G20)	MIN - MAX	m ³ /h	1.30 - 15.90	1.30 - 21.10
Gas flow rate at LPG burner (G31)	MIN - MAX	kg/h	0.9 - 11.6	0.9 - 15.5
Electric power supply		V/Hz	230 - 50	230 - 50
Maximum absorbed electric power		W	210	290
Minimum absorbed electric power		W	26	26
Fuse on power supply		A (F)	4	4
Electric insulation rating	IP		X5D	X5D
Boiler water content		litres	14.2	18.3
Net - gross boiler weight		kg	236 - 220	295 - 273
Effective efficiency at 100% output (Italian Lgs. D. 192/05 as amended)			>93+2·log Pn (Pn = 146.1 kW)	>93+2·log Pn (Pn = 195.2 kW)

ARES 150 - 350 TEC ErP

34.1

TECHNICAL DATA

			ARES 250 TEC ErP	ARES 300 TEC ErP
Maximum nominal heat input		kW (kcal/h)	250 (215.000)	300 (258.000)
Maximum useful heat output (80/60°C)		kW (kcal/h)	244.5 (210.270)	294.0 (252.840)
Maximum useful heat output (50/30°C)		kW (kcal/h)	251.3 (216.118)	302.7 (260.322)
Minimum nominal heat input		kW (kcal/h)	12 (10.356)	12 (10.356)
Minimum nominal heat output (80/60°C)		kW (kcal/h)	11.7 (10.062)	11.7 (10.062)
Minimum nominal heat output (50/30°C)		kW (kcal/h)	12.8 (11.008)	12.8 (11.008)
Efficiency at 100% Pn (80/60°C)		%	97.8	98.0
Efficiency at 30% of the load (80/60°C)		%	96.2	96.4
Efficiency at 100% Pn (50/30°C)		%	100.5	100.9
Efficiency at 30% of the load (T. r. 30°C)		%	107.3	107.3
Central heating circuit				
Central heating system adjustable temperature		°C	25-85	25-85
System max. working temperature		°C	90	90
System max. working pressure		bar	6.0	6.0
System min. working pressure		bar	0.5	0.5
Water flow rate at nom. power (ΔT 20° C)		l/h	10.514	12.642
Gas supply				
METHANE fan speed (G20)	MIN - MAX	No. revs	1860 - 5880	1860 - 5880
LPG fan speed (G31)	MIN - MAX	No. revs	1800 - 5460	1800 - 5460
Gas flow rate at METHANE burner (G20)	MIN - MAX	m ³ /h	1.30 - 26.40	1.30 - 31.70
Gas flow rate at LPG burner (G31)	MIN - MAX	kg/h	0.93 - 19.40	0.93 - 23.30
Electric power supply		V/Hz	230 - 50	230 - 50
Maximum absorbed electric power		W	362	435
Minimum absorbed electric power		W	26	26
Fuse on power supply		A (F)	4	4
Electric insulation rating	IP		X5D	X5D
Boiler water content		litres	22.4	26.5
Net - gross boiler weight		kg	325 - 308	386 - 365
Effective efficiency at 100% output (Italian Lgs. D. 192/05 as amended)			>93+2·log Pn (Pn = 244.5 kW)	>93+2·log Pn (Pn = 294.0 kW)

34.2
TECHNICAL DATA

			ARES 350 TEC ErP	ARES 440 TEC ErP
Maximum nominal heat input		kW (kcal/h)	348 (299.280)	432 (371.520)
Maximum useful heat output (80/60°C)		kW (kcal/h)	341.7 (293,862)	424.3 (364.872)
Maximum useful heat output (50/30°C)		kW (kcal/h)	354.6 (304.964)	445.0 (382.700)
Minimum nominal heat input		kW (kcal/h)	12 (10.356)	22 (18.920)
Minimum nominal heat output (80/60°C)		kW (kcal/h)	11.7 (10.062)	20.6 (17.716)
Minimum nominal heat output (50/30°C)		kW (kcal/h)	12.8 (11.008)	23.9 (20.554)
Efficiency at 100% Pn (80/60°C)		%	98.2	98.21
Efficiency at 30% of the load (80/60°C)		%	96.6	96.6
Efficiency at 100% Pn (50/30°C)		%	101.9	104.0
Efficiency at 30% of the load (T. r. 30°C)		%	107.3	107.3
Central heating circuit				
Central heating system adjustable temperature		°C	25-85	25-85
System max. working temperature		°C	90	90
System max. working pressure		bar	6.0	6.0
System min. working pressure		bar	0.5	0.5
Water flow rate at nom. power (ΔT 20° C)		l/h	14.699	18.243
Gas supply				
METHANE fan speed (G20)	MIN - MAX	No. revs	1860 - 5880	1700 - 5540
LPG fan speed (G31)	MIN - MAX	No. revs	1800 - 5460	1700 - 5290
Gas flow rate at METHANE burner (G20)	MIN - MAX	m ³ /h	1.30 - 36.80	2.33 - 45.68
Gas flow rate at LPG burner (G31)	MIN - MAX	kg/h	0.90 - 27.00	1.71 - 33.53
Electric power supply		V/Hz	230 - 50	230 - 50
Maximum absorbed electric power		W	507	626
Minimum absorbed electric power		W	26	54
Fuse on power supply		A (F)	4	4
Electric insulation rating	IP		X5D	X5D
Boiler water content		litres	30.6	73
Net - gross boiler weight		kg	419 - 390	585 - 536
Effective efficiency at 100% output (Italian Lgs. D. 192/05 as amended)			>93+2·log Pn (Pn = 341.7 kW)	>93+2·log Pn (Pn = 424.3 kW)

ARES 440 - 900 TEC ErP

34.3

TECHNICAL DATA

			ARES 550 TEC ErP	ARES 660 TEC ErP
Maximum nominal heat input		kW (kcal/h)	540 (464.400)	648 (557.280)
Maximum useful heat output (80/60°C)		kW (kcal/h)	530.4 (456.144)	636.5 (547.390)
Maximum useful heat output (50/30°C)		kW (kcal/h)	557.8 (479.725)	670.0 (576.200)
Minimum nominal heat input		kW (kcal/h)	22 (18.920)	22 (18.920)
Minimum nominal heat output (80/60°C)		kW (kcal/h)	20.6 (17.716)	20.6 (17.716)
Minimum nominal heat output (50/30°C)		kW (kcal/h)	23.9 (20.554)	23.9 (20.554)
Efficiency at 100% Pn (80/60°C)		%	98.21	98.21
Efficiency at 30% of the load (80/60°C)		%	96.6	96.6
Efficiency at 100% Pn (50/30°C)		%	104.0	104.0
Efficiency at 30% of the load (T. r. 30°C)		%	107.5	108.3
Central heating circuit				
Central heating system adjustable temperature		°C	25-85	25-85
System max. working temperature		°C	90	90
System max. working pressure		bar	6.0	6.0
System min. working pressure		bar	0.5	0.5
Water flow rate at nom. power (ΔT 20° C)		l/h	22.804	27.365
Gas supply				
METHANE fan speed (G20)	MIN - MAX	No. revs	1700 - 5540	1700 - 5540
LPG fan speed (G31)	MIN - MAX	No. revs	1700 - 5290	1700 - 5290
Gas flow rate at METHANE burner (G20)	MIN - MAX	m ³ /h	2.33 - 57.10	2.33 - 68.52
Gas flow rate at LPG burner (G31)	MIN - MAX	kg/h	1.71 - 41.92	1.71 - 50.30
Electric power supply		V/Hz	230 - 50	230 - 50
Maximum absorbed electric power		W	783	940
Minimum absorbed electric power		W	54	54
Fuse on power supply		A (F)	4	4
Electric insulation rating	IP		X5D	X5D
Boiler water content		litres	88	103
Net - gross boiler weight		kg	643 - 618	707 - 677
Effective efficiency at 100% output (Italian Lgs. D. 192/05 as amended)			>93+2·log Pn (Pn = 530.4 kW)	>93+2·log Pn (Pn = 636.5 kW)

34.4
TECHNICAL DATA

			ARES 770 TEC ErP	ARES 900 TEC ErP
Maximum nominal heat input		kW (kcal/h)	756 (650.160)	864.0 (743.040)
Maximum useful heat output (80/60°C)		kW (kcal/h)	742.6 (638.636)	849.0 (730.140)
Maximum useful heat output (50/30°C)		kW (kcal/h)	783.2 (673.569)	900.3 (774.249)
Minimum nominal heat input		kW (kcal/h)	22 (18.920)	22 (18.920)
Minimum nominal heat output (80/60°C)		kW (kcal/h)	20.6 (17.716)	20.6 (17.716)
Minimum nominal heat output (50/30°C)		kW (kcal/h)	23.9 (20.554)	23.9 (20.554)
Efficiency at 100% Pn (80/60°C)		%	98.2	98.2
Efficiency at 30% of the load (80/60°C)		%	96.6	96.6
Efficiency at 100% Pn (50/30°C)		%	104.0	104.0
Efficiency at 30% of the load (T. r. 30°C)		%	107.8	107.6
Central heating circuit				
Central heating system adjustable temperature		°C	25-85	25-85
System max. working temperature		°C	90	90
System max. working pressure		bar	6.0	6.0
System min. working pressure		bar	0.5	0.5
Water flow rate at nom. power (ΔT 20° C)		l/h	31.926	36.487
Gas supply				
METHANE fan speed (G20)	MIN - MAX	No. revs	1700 - 5540	1700 - 5540
LPG fan speed (G31)	MIN - MAX	No. revs	1700 - 5290	1700 - 5290
Gas flow rate at METHANE burner (G20)	MIN - MAX	m ³ /h	2.33 - 79.94	2.33 - 91.36
Gas flow rate at LPG burner (G31)	MIN - MAX	kg/h	1.71 - 58.68	1.71 - 67.01
Electric power supply		V/Hz	230 - 50	230 - 50
Maximum absorbed electric power		W	1096	1252
Minimum absorbed electric power		W	54	54
Fuse on power supply		A (F)	4	4
Electric insulation rating	IP		X5D	X5D
Boiler water content		litres	118	133
Net - gross boiler weight		kg	806 - 786	858 - 840
Effective efficiency at 100% output (Italian Lgs. D. 192/05 as amended)			>93+2·log Pn (Pn = 742.6 kW)	>93+2·log Pn (Pn = 849.0 kW)

ARES 150 - 350 TEC ErP

35

ARES 150TEC ErP COMBUSTION FEATURES

		Methane (G20)	LPG (G31)
Combustion efficiency 100% Pn (80/60°C)	%	97.8	97.8
Combustion efficiency P min (80/60°C)	%	98.3	98.3
Effective efficiency at 100% Pn (80/60°C)	%	97.4	97.4
Effective efficiency P min (80/60°C)	%	97.16	97.16
Effective efficiency at 100% Pn (50/30°C)	%	100.0	100.0
Effective efficiency P min (50/30°C)	%	106.5	106.5
Chimney losses with burner on (100% Pn) (80/60°C)	%	2.2	2.2
Chimney losses with burner on (P min) (80/60°C)	%	1.7	1.7
Chimney losses with burner off	%	0.3	0.3
Casing losses with burner on (100% Pn) (80/60°C)	%	0.4	0.4
Casing losses with burner on (P min) (80/60°C)	%	1.23	1.23
Casing losses with burner off	%	0.1	0.1
Flue gas temperature Maximum Heat Input	°C	45.1	-
Flue gas temperature Minimum Heat Input	°C	33.4	-
Flue gas flow rate at Maximum Heat Input	kg/h	245.2	-
Flue flow rate at Minimum Heat Input	kg/h	19.6	-
CO ₂ at Maximum Heat Input	%	9.1	10.8
CO ₂ at Minimum Heat Input	%	9.1	10.8
CO at Maximum Heat Input	mg/kWh	93.7	-
CO at Minimum Heat Input	mg/kWh	2.5	-
NO _x at the Maximum Heat Input	mg/kWh	85.7	-
NO _x at Minimum Heat Input	mg/kWh	48.9	-
Weighted CO	mg/kWh	32.4	-
Weighted NO _x	mg/kWh	53.8	-
NO _x class	-	6	6
Maximum pressure available at chimney base	Pa	100	
Max. condensate production	kg/h	24.2	

- Gas flow rates refer to the NHV at the temperature of 15° C and pressure of 1013 mbar.
- Flue gas temperature values refer to an air inlet temperature of 15°C and flow temperature of 80°C.
- The maximum sound level emitted during boiler operation is < 49dBA. The sound level value refers to semi-anechoic chamber tests with boiler operating at max. heat input, with extension of flue gas exhaust system according to product standards.

35.1 ARES 200TEC ErP COMBUSTION FEATURES

		Methane (G20)	LPG (G31)
Combustion efficiency 100% Pn (80/60°C)	%	97.8	97.8
Combustion efficiency P min (80/60°C)	%	98.3	98.3
Effective efficiency at 100% Pn (80/60°C)	%	97.6	97.6
Effective efficiency P min (80/60°C)	%	97.16	97.16
Effective efficiency at 100% Pn (50/30°C)	%	100.2	100.2
Effective efficiency P min (50/30°C)	%	106.5	106.5
Chimney losses with burner on (100% Pn) (80/60°C)	%	2.2	2.2
Chimney losses with burner on (P min) (80/60°C)	%	1.7	1.7
Chimney losses with burner off	%	0.3	0.3
Casing losses with burner on (100% Pn) (80/60°C)	%	0.2	0.2
Casing losses with burner on (P min) (80/60°C)	%	1.23	1.23
Casing losses with burner off	%	0.1	0.1
Flue gas temperature Maximum Heat Input	°C	46.5	-
Flue gas temperature Minimum Heat Input	°C	33.4	-
Flue gas flow rate at Maximum Heat Input	kg/h	326.9	-
Flue flow rate at Minimum Heat Input	kg/h	19.6	-
CO ₂ at Maximum Heat Input	%	9.1	10.8
CO ₂ at Minimum Heat Input	%	9.1	10.8
CO at Maximum Heat Input	mg/kWh	93.7	-
CO at Minimum Heat Input	mg/kWh	2.5	-
NO _x at the Maximum Heat Input	mg/kWh	85.7	-
NO _x at Minimum Heat Input	mg/kWh	48.9	-
Weighted CO	mg/kWh	32.4	-
Weighted NO _x	mg/kWh	53.8	-
NO _x class	-	6	6
Maximum pressure available at chimney base	Pa	100	
Max. condensate production	kg/h	32.2	

- Gas flow rates refer to the NHV at the temperature of 15° C and pressure of 1013 mbar.
- Flue gas temperature values refer to an air inlet temperature of 15°C and flow temperature of 80°C.
- The maximum sound level emitted during boiler operation is < 49dBA. The sound level value refers to semi-anechoic chamber tests with boiler operating at max. heat input, with extension of flue gas exhaust system according to product standards.

ARES 150 - 350 TEC ErP

35.2

ARES 250TEC ErP COMBUSTION FEATURES

		Methane (G20)	LPG (G31)
Combustion efficiency 100% Pn (80/60°C)	%	98.0	98.0
Combustion efficiency P min (80/60°C)	%	98.3	98.3
Effective efficiency at 100% Pn (80/60°C)	%	97.8	97.8
Effective efficiency P min (80/60°C)	%	97.16	97.16
Effective efficiency at 100% Pn (50/30°C)	%	100.5	100.5
Effective efficiency P min (50/30°C)	%	106.5	106.5
Chimney losses with burner on (100% Pn) (80/60°C)	%	2.0	2.0
Chimney losses with burner on (P min) (80/60°C)	%	1.7	1.7
Chimney losses with burner off	%	0.3	0.3
Casing losses with burner on (100% Pn) (80/60°C)	%	0.2	0.2
Casing losses with burner on (P min) (80/60°C)	%	1.23	1.23
Casing losses with burner off	%	0.1	0.1
Flue gas temperature Maximum Heat Input	°C	47.3	-
Flue gas temperature Minimum Heat Input	°C	33.4	-
Flue gas flow rate at Maximum Heat Input	kg/h	408.6	-
Flue flow rate at Minimum Heat Input	kg/h	19.6	-
CO ₂ at Maximum Heat Input	%	9.1	10.8
CO ₂ at Minimum Heat Input	%	9.1	10.8
CO at Maximum Heat Input	mg/kWh	93.7	-
CO at Minimum Heat Input	mg/kWh	2.5	-
NO _x at the Maximum Heat Input	mg/kWh	85.7	-
NO _x at Minimum Heat Input	mg/kWh	48.9	-
Weighted CO	mg/kWh	32.4	-
Weighted NO _x	mg/kWh	53.8	-
NO _x class	-	6	6
Maximum pressure available at chimney base	Pa	100	
Max. condensate production	kg/h	40.3	

- Gas flow rates refer to the NHV at the temperature of 15° C and pressure of 1013 mbar.
- Flue gas temperature values refer to an air inlet temperature of 15°C and flow temperature of 80°C.
- The maximum sound level emitted during boiler operation is < 49dBA. The sound level value refers to semi-anechoic chamber tests with boiler operating at max. heat input, with extension of flue gas exhaust system according to product standards.

35.3 ARES 300TEC ErP COMBUSTION FEATURES

		Methane (G20)	LPG (G31)
Combustion efficiency 100% Pn (80/60°C)	%	98.1	98.1
Combustion efficiency P min (80/60°C)	%	98.3	98.3
Effective efficiency at 100% Pn (80/60°C)	%	98.0	98.0
Effective efficiency P min (80/60°C)	%	97.16	97.16
Effective efficiency at 100% Pn (50/30°C)	%	100.9	100.9
Effective efficiency P min (50/30°C)	%	106.5	106.5
Chimney losses with burner on (100% Pn) (80/60°C)	%	1.9	1.9
Chimney losses with burner on (P min) (80/60°C)	%	1.7	1.7
Chimney losses with burner off	%	0.3	0.3
Casing losses with burner on (100% Pn) (80/60°C)	%	0.1	0.1
Casing losses with burner on (P min) (80/60°C)	%	1.23	1.23
Casing losses with burner off	%	0.1	0.1
Flue gas temperature Maximum Heat Input	°C	48.2	-
Flue gas temperature Minimum Heat Input	°C	33.4	-
Flue gas flow rate at Maximum Heat Input	kg/h	490.3	-
Flue flow rate at Minimum Heat Input	kg/h	19.6	-
CO ₂ at Maximum Heat Input	%	9.1	10.8
CO ₂ at Minimum Heat Input	%	9.1	10.8
CO at Maximum Heat Input	mg/kWh	93.7	-
CO at Minimum Heat Input	mg/kWh	2.5	-
NO _x at the Maximum Heat Input	mg/kWh	85.7	-
NO _x at Minimum Heat Input	mg/kWh	48.9	-
Weighted CO	mg/kWh	32.4	-
Weighted NO _x	mg/kWh	53.8	-
NO _x class	-	6	6
Maximum pressure available at chimney base	Pa	100	
Max. condensate production	kg/h	48.3	

- Gas flow rates refer to the NHV at the temperature of 15° C and pressure of 1013 mbar.
- Flue gas temperature values refer to an air inlet temperature of 15°C and flow temperature of 80°C.
- The maximum sound level emitted during boiler operation is < 49dBA. The sound level value refers to semi-anechoic chamber tests with boiler operating at max. heat input, with extension of flue gas exhaust system according to product standards.

ARES 150 - 350 TEC ErP

35.4 ARES 350TEC ErP COMBUSTION FEATURES

		Methane (G20)	LPG (G31)
Combustion efficiency 100% Pn (80/60°C)	%	98.3	98.3
Combustion efficiency P min (80/60°C)	%	98.3	98.3
Effective efficiency at 100% Pn (80/60°C)	%	98.2	98.2
Effective efficiency P min (80/60°C)	%	97.16	97.16
Effective efficiency at 100% Pn (50/30°C)	%	101.9	101.9
Effective efficiency P min (50/30°C)	%	106.5	106.5
Chimney losses with burner on (100% Pn) (80/60°C)	%	1.7	1.7
Chimney losses with burner on (P min) (80/60°C)	%	1.7	1.7
Chimney losses with burner off	%	0.3	0.3
Casing losses with burner on (100% Pn) (80/60°C)	%	0.1	0.1
Casing losses with burner on (P min) (80/60°C)	%	1.23	1.23
Casing losses with burner off	%	0.1	0.1
Flue gas temperature Maximum Heat Input	°C	49.1	-
Flue gas temperature Minimum Heat Input	°C	33.4	-
Flue gas flow rate at Maximum Heat Input	kg/h	568.8	-
Flue flow rate at Minimum Heat Input	kg/h	19.6	-
CO ₂ at Maximum Heat Input	%	9.1	10.8
CO ₂ at Minimum Heat Input	%	9.1	10.8
CO at Maximum Heat Input	mg/kWh	93.7	-
CO at Minimum Heat Input	mg/kWh	2.5	-
NO _x at the Maximum Heat Input	mg/kWh	85.7	-
NO _x at Minimum Heat Input	mg/kWh	48.9	-
Weighted CO	mg/kWh	32.4	-
Weighted NO _x	mg/kWh	53.8	-
NO _x class	-	6	6
Maximum pressure available at chimney base	Pa	100	
Max. condensate production	kg/h	56.0	

- Gas flow rates refer to the NHV at the temperature of 15° C and pressure of 1013 mbar.
- Flue gas temperature values refer to an air inlet temperature of 15°C and flow temperature of 80°C.
- The maximum sound level emitted during boiler operation is < 49dBA. The sound level value refers to semi-anechoic chamber tests with boiler operating at max. heat input, with extension of flue gas exhaust system according to product standards.

35.5
ARES 440TEC ErP COMBUSTION FEATURES

		Methane (G20)	LPG (G31)
Combustion efficiency 100% Pn (80/60°C)	%	97.8	97.8
Combustion efficiency P min (80/60°C)	%	98.5	98.5
Effective efficiency at 100% Pn (80/60°C)	%	98.2	98.2
Effective efficiency P min (80/60°C)	%	93.5	93.5
Effective efficiency at 100% Pn (50/30°C)	%	104.0	104.0
Effective efficiency P min (50/30°C)	%	109.0	109.0
Chimney losses with burner on (100% Pn) (80/60°C)	%	2.58	2.58
Chimney losses with burner on (P min) (80/60°C)	%	1.5	1.5
Chimney losses with burner off	%	0.1	0.1
Casing losses with burner on (100% Pn) (80/60°C)	%	0.1	0.1
Casing losses with burner on (P min) (80/60°C)	%	5.04	5.04
Casing losses with burner off	%	0.1	0.1
Flue gas temperature Maximum Heat Input	°C	46.7	-
Flue gas temperature Minimum Heat Input	°C	31.0	-
Flue gas flow rate at Maximum Heat Input	kg/h	693	-
Flue flow rate at Minimum Heat Input	kg/h	25	-
CO ₂ at Maximum Heat Input	%	9.1	10.6
CO ₂ at Minimum Heat Input	%	9.1	10.2
CO at Maximum Heat Input	mg/kWh	93.1	-
CO at Minimum Heat Input	mg/kWh	1.4	-
NO _x at the Maximum Heat Input	mg/kWh	68	-
NO _x at Minimum Heat Input	mg/kWh	46	-
Weighted CO	mg/kWh	26.3	-
Weighted NO _x	mg/kWh	47	-
NO _x class	-	6	6
Maximum pressure available at chimney base	Pa	100	
Max. condensate production	kg/h	73.4	

- Gas flow rates refer to the NHV at the temperature of 15° C and pressure of 1013 mbar.
- Flue gas temperature values refer to an air inlet temperature of 15°C and flow temperature of 80°C.
- The maximum sound level emitted during boiler operation is < 49dBA. The sound level value refers to semi-anechoic chamber tests with boiler operating at max. heat input, with extension of flue gas exhaust system according to product standards.

ARES 440 - 900 TEC ErP

35.6

ARES 550TEC ErP COMBUSTION FEATURES

		Methane (G20)	LPG (G31)
Combustion efficiency 100% Pn (80/60°C)	%	97.8	97.8
Combustion efficiency P min (80/60°C)	%	98.5	98.5
Effective efficiency at 100% Pn (80/60°C)	%	98.21	98.21
Effective efficiency P min (80/60°C)	%	93.5	93.5
Effective efficiency at 100% Pn (50/30°C)	%	104.0	104.0
Effective efficiency P min (50/30°C)	%	109.0	109.0
Chimney losses with burner on (100% Pn) (80/60°C)	%	2.53	2.53
Chimney losses with burner on (P min) (80/60°C)	%	1.57	1.57
Chimney losses with burner off	%	0.1	0.1
Casing losses with burner on (100% Pn) (80/60°C)	%	0.1	0.1
Casing losses with burner on (P min) (80/60°C)	%	5.04	5.04
Casing losses with burner off	%	0.1	0.1
Flue gas temperature Maximum Heat Input	°C	46.7	-
Flue gas temperature Minimum Heat Input	°C	31.0	-
Flue gas flow rate at Maximum Heat Input	kg/h	866	-
Flue flow rate at Minimum Heat Input	kg/h	25	-
CO ₂ at Maximum Heat Input	%	9.1	10.6
CO ₂ at Minimum Heat Input	%	9.1	10.2
CO at Maximum Heat Input	mg/kWh	93.1	-
CO at Minimum Heat Input	mg/kWh	1.4	-
NO _x at the Maximum Heat Input	mg/kWh	68	-
NO _x at Minimum Heat Input	mg/kWh	46	-
Weighted CO	mg/kWh	26.3	-
Weighted NO _x	mg/kWh	47	-
NO _x class	-	6	6
Maximum pressure available at chimney base	Pa	100	
Max. condensate production	kg/h	91.7	

- Gas flow rates refer to the NHV at the temperature of 15° C and pressure of 1013 mbar.
- Flue gas temperature values refer to an air inlet temperature of 15°C and flow temperature of 80°C.
- The maximum sound level emitted during boiler operation is < 49dBA. The sound level value refers to semi-anechoic chamber tests with boiler operating at max. heat input, with extension of flue gas exhaust system according to product standards.

35.7
ARES 660TEC ErP COMBUSTION FEATURES

		Methane (G20)	LPG (G31)
Combustion efficiency 100% Pn (80/60°C)	%	97.8	97.8
Combustion efficiency P min (80/60°C)	%	98.5	98.5
Effective efficiency at 100% Pn (80/60°C)	%	98.21	98.21
Effective efficiency P min (80/60°C)	%	93.5	93.5
Effective efficiency at 100% Pn (50/30°C)	%	104.0	104.0
Effective efficiency P min (50/30°C)	%	109.0	109.0
Chimney losses with burner on (100% Pn) (80/60°C)	%	2.51	2.51
Chimney losses with burner on (P min) (80/60°C)	%	1.57	1.57
Chimney losses with burner off	%	0.1	0.1
Casing losses with burner on (100% Pn) (80/60°C)	%	0.1	0.1
Casing losses with burner on (P min) (80/60°C)	%	5.04	5.04
Casing losses with burner off	%	0.1	0.1
Flue gas temperature Maximum Heat Input	°C	46.7	-
Flue gas temperature Minimum Heat Input	°C	31.0	-
Flue gas flow rate at Maximum Heat Input	kg/h	1040	-
Flue flow rate at Minimum Heat Input	kg/h	25	-
CO ₂ at Maximum Heat Input	%	9.1	10.6
CO ₂ at Minimum Heat Input	%	9.1	10.2
CO at Maximum Heat Input	mg/kWh	93.1	-
CO at Minimum Heat Input	mg/kWh	1.4	-
NO _x at the Maximum Heat Input	mg/kWh	68	-
NO _x at Minimum Heat Input	mg/kWh	46	-
Weighted CO	mg/kWh	26.3	-
Weighted NO _x	mg/kWh	47	-
NO _x class	-	6	6
Maximum pressure available at chimney base	Pa	100	
Max. condensate production	kg/h	110	

- Gas flow rates refer to the NHV at the temperature of 15° C and pressure of 1013 mbar.
- Flue gas temperature values refer to an air inlet temperature of 15°C and flow temperature of 80°C.
- The maximum sound level emitted during boiler operation is < 49dBA. The sound level value refers to semi-anechoic chamber tests with boiler operating at max. heat input, with extension of flue gas exhaust system according to product standards.

ARES 440 - 900 TEC ErP

35.8

ARES 770TEC ErP COMBUSTION FEATURES

		Methane (G20)	LPG (G31)
Combustion efficiency 100% Pn (80/60°C)	%	97.8	97.8
Combustion efficiency P min (80/60°C)	%	98.5	98.5
Effective efficiency at 100% Pn (80/60°C)	%	98.21	98.21
Effective efficiency P min (80/60°C)	%	93.5	93.5
Effective efficiency at 100% Pn (50/30°C)	%	104.0	104.0
Effective efficiency P min (50/30°C)	%	109.0	109.0
Chimney losses with burner on (100% Pn) (80/60°C)	%	2.58	2.58
Chimney losses with burner on (P min) (80/60°C)	%	1.57	1.57
Chimney losses with burner off	%	0.1	0.1
Casing losses with burner on (100% Pn) (80/60°C)	%	0.1	0.1
Casing losses with burner on (P min) (80/60°C)	%	5.04	5.04
Casing losses with burner off	%	0.1	0.1
Flue gas temperature Maximum Heat Input	°C	46.7	-
Flue gas temperature Minimum Heat Input	°C	31.0	-
Flue gas flow rate at Maximum Heat Input	kg/h	1213	-
Flue flow rate at Minimum Heat Input	kg/h	25	-
CO ₂ at Maximum Heat Input	%	9.1	10.6
CO ₂ at Minimum Heat Input	%	9.1	10.2
CO at Maximum Heat Input	mg/kWh	93.1	-
CO at Minimum Heat Input	mg/kWh	1.4	-
NO _x at the Maximum Heat Input	mg/kWh	68	-
NO _x at Minimum Heat Input	mg/kWh	46	-
Weighted CO	mg/kWh	26.3	-
Weighted NO _x	mg/kWh	47	-
NO _x class	-	6	6
Maximum pressure available at chimney base	Pa	100	
Max. condensate production	kg/h	128.4	

- Gas flow rates refer to the NHV at the temperature of 15° C and pressure of 1013 mbar.
- Flue gas temperature values refer to an air inlet temperature of 15°C and flow temperature of 80°C.
- The maximum sound level emitted during boiler operation is < 49dBA. The sound level value refers to semi-anechoic chamber tests with boiler operating at max. heat input, with extension of flue gas exhaust system according to product standards.

35.9
ARES 900TEC ErP COMBUSTION FEATURES

		Methane (G20)	LPG (G31)
Combustion efficiency 100% Pn (80/60°C)	%	97.8	97.8
Combustion efficiency P min (80/60°C)	%	98.5	98.5
Effective efficiency at 100% Pn (80/60°C)	%	98.21	98.21
Effective efficiency P min (80/60°C)	%	93.5	93.5
Effective efficiency at 100% Pn (50/30°C)	%	104.0	104.0
Effective efficiency P min (50/30°C)	%	109.0	109.0
Chimney losses with burner on (100% Pn) (80/60°C)	%	2.58	2.58
Chimney losses with burner on (P min) (80/60°C)	%	1.57	1.57
Chimney losses with burner off	%	0.1	0.1
Casing losses with burner on (100% Pn) (80/60°C)	%	0.1	0.1
Casing losses with burner on (P min) (80/60°C)	%	5.04	5.04
Casing losses with burner off	%	0.1	0.1
Flue gas temperature Maximum Heat Input	°C	45.8	-
Flue gas temperature Minimum Heat Input	°C	31.0	-
Flue gas flow rate at Maximum Heat Input	kg/h	1386	-
Flue flow rate at Minimum Heat Input	kg/h	25	-
CO ₂ at Maximum Heat Input	%	9.1	10.6
CO ₂ at Minimum Heat Input	%	9.1	10.2
CO at Maximum Heat Input	mg/kWh	93.1	-
CO at Minimum Heat Input	mg/kWh	1.4	-
NO _x at the Maximum Heat Input	mg/kWh	68	-
NO _x at Minimum Heat Input	mg/kWh	46	-
Weighted CO	mg/kWh	26.3	-
Weighted NO _x	mg/kWh	47	-
NO _x class	-	6	6
Maximum pressure available at chimney base	Pa	100	
Max. condensate production	kg/h	146.7	

- Gas flow rates refer to the NHV at the temperature of 15° C and pressure of 1013 mbar.
- Flue gas temperature values refer to an air inlet temperature of 15°C and flow temperature of 80°C.
- The maximum sound level emitted during boiler operation is < 49dBA. The sound level value refers to semi-anechoic chamber tests with boiler operating at max. heat input, with extension of flue gas exhaust system according to product standards.

ARES TEC ErP

36 TECHNICAL PARAMETERS FOR COMBINATION BOILERS (REGULATION 813/2013)

Efficiencies in the following tables refer to the gross calorific value.

Model/s:				ARES 150 TEC ErP				
Condensing Boilers:				YES				
Low temperature boiler:				NO				
Boiler type B1:				NO				
Co-generation appliance for central heating:				NO		Fitted with supplementary heating system:		NO
Combination heating appliance:				NO				
Element	Symbol	Value	Unit	Element	Symbol	Value	Unit	
Nominal heat output	P_n	146	kW	Seasonal energy efficiency of central heating	η_s	92	%	
For heating only boilers and combination boilers: useful heat output				For central heating only and combination boilers: effective efficiency				
At nominal heat output in high temperature mode (*)	P_4	146.1	kW	At nominal heat output in high temperature mode (*)	η_4	87.7	%	
At 30% of nominal heat output in a low temperature mode (**)	P_1	49.3	kW	At 30% of nominal heat output in a low temperature mode (**)	η_1	96.7	%	
Auxiliary electricity consumption				Other items				
At full load	el_{max}	0.210	kW	Heat loss in standby	P_{stby}	0.94	kW	
At partial load	el_{min}	0.040	kW	Ignition burner energy consumption	P_{ign}	459	kW	
In standby mode	P_{SB}	0.000	kW	Emissions of nitrogen oxides	NO_x	54 (49)	mg / kWh	
For combination central heating appliances								
Stated load profile				Domestic hot water production efficiency	η_{WH}		%	
Daily electrical power consumption	Q_{elec}		kWh	Daily gas consumption	Q_{fuel}		kWh	
Contact information	IMMERGAS S.p.A. VIA CISA LIGURE, 95 - 42041 BRESCELLO (RE) ITALY							
(*) High temperature mode means 60°C on return and 80°C on flow. (**) Low temperature mode for condensation Boilers means 30°C, for low temperature boilers 37°C and for other appliances 50°C return temperature.								

Efficiencies in the following tables refer to the gross calorific value.

Model/s:				ARES 200 TEC ErP					
Condensing Boilers:				YES					
Low temperature boiler:				NO					
Boiler type B1:				NO					
Co-generation appliance for central heating:				NO			Fitted with supplementary heating system:	NO	
Combination heating appliance:				NO					
Element	Symbol	Value	Unit	Element	Symbol	Value	Unit		
Nominal heat output	P_n	195	kW	Seasonal energy efficiency of central heating	η_s	92	%		
For heating only boilers and combination boilers: useful heat output				For central heating only and combination boilers: effective efficiency					
At nominal heat output in high temperature mode (*)	P_4	195.2	kW	At nominal heat output in high temperature mode (*)	η_4	87.7	%		
At 30% of nominal heat output in a low temperature mode (**)	P_1	64.4	kW	At 30% of nominal heat output in a low temperature mode (**)	η_1	96.7	%		
Auxiliary electricity consumption				Other items					
At full load	el_{max}	0.290	kW	Heat loss in standby	P_{stby}	0.98	kW		
At partial load	el_{min}	0.040	kW	Ignition burner energy consumption	P_{ign}	612	kW		
In standby mode	P_{SB}	0.010	kW	Emissions of nitrogen oxides	NO_x	54 (49)	mg / kWh		
For combination central heating appliances									
Stated load profile				Domestic hot water production efficiency				η_{WH}	%
Daily electrical power consumption				Q_{elec}	kWh	Daily gas consumption		Q_{fuel}	kWh
Contact information		IMMERGAS S.p.A. VIA CISA LIGURE, 95 - 42041 BRESCELLO (RE) ITALY							
(*) High temperature mode means 60°C on return and 80°C on flow. (**) Low temperature mode for condensation Boilers means 30°C, for low temperature boilers 37°C and for other appliances 50°C return temperature.									

Efficiencies in the following tables refer to the gross calorific value.

Model/s:				ARES 250 TEC ErP					
Condensing Boilers:				YES					
Low temperature boiler:				NO					
Boiler type B1:				NO					
Co-generation appliance for central heating:				NO			Fitted with supplementary heating system:	NO	
Combination heating appliance:				NO					
Element	Symbol	Value	Unit	Element	Symbol	Value	Unit		
Nominal heat output	P_n	244	kW	Seasonal energy efficiency of central heating	η_s	92	%		
For heating only boilers and combination boilers: useful heat output				For central heating only and combination boilers: effective efficiency					
At nominal heat output in high temperature mode (*)	P_4	244.5	kW	At nominal heat output in high temperature mode (*)	η_4	88.1	%		
At 30% of nominal heat output in a low temperature mode (**)	P_1	80.5	kW	At 30% of nominal heat output in a low temperature mode (**)	η_1	96.7	%		
Auxiliary electricity consumption				Other items					
At full load	el_{max}	0.362	kW	Heat loss in standby	P_{stby}	1.1	kW		
At partial load	el_{min}	0.040	kW	Ignition burner energy consumption	P_{ign}	766	kW		
In standby mode	P_{SB}	0.010	kW	Emissions of nitrogen oxides	NO_x	54 (49)	mg / kWh		
For combination central heating appliances									
Stated load profile				Domestic hot water production efficiency				η_{WH}	%
Daily electrical power consumption				Q_{elec}	kWh	Daily gas consumption		Q_{fuel}	kWh
Contact information		IMMERGAS S.p.A. VIA CISA LIGURE, 95 - 42041 BRESCELLO (RE) ITALY							
(*) High temperature mode means 60°C on return and 80°C on flow. (**) Low temperature mode for condensation Boilers means 30°C, for low temperature boilers 37°C and for other appliances 50°C return temperature.									

ARES TEC ErP

Efficiencies in the following tables refer to the gross calorific value.

Model/s:				ARES 300 TEC ErP				
Condensing Boilers:				YES				
Low temperature boiler:				NO				
Boiler type B1:				NO				
Co-generation appliance for central heating:				NO			Fitted with supplementary heating system:	NO
Combination heating appliance:				NO				
Element	Symbol	Value	Unit	Element	Symbol	Value	Unit	
Nominal heat output	P_n	294	kW	Seasonal energy efficiency of central heating	η_s	92	%	
For heating only boilers and combination boilers: useful heat output				For central heating only and combination boilers: effective efficiency				
At nominal heat output in high temperature mode (*)	P_4	294.0	kW	At nominal heat output in high temperature mode (*)	η_4	88.3	%	
At 30% of nominal heat output in a low temperature mode (**)	P_1	96.6	kW	At 30% of nominal heat output in a low temperature mode (**)	η_1	96.7	%	
Auxiliary electricity consumption				Other items				
At full load	el_{max}	0.435	kW	Heat loss in standby	P_{stby}	1.15	kW	
At partial load	el_{min}	0.040	kW	Ignition burner energy consumption	P_{ign}	920	kW	
In standby mode	P_{SB}	0.010	kW	Emissions of nitrogen oxides	NO_x	54 (49)	mg / kWh	
For combination central heating appliances								
Stated load profile				Domestic hot water production efficiency		η_{WH}	%	
Daily electrical power consumption				Q_{elec}	kWh	Daily gas consumption		
Contact information				IMMERGAS S.p.A. VIA CISA LIGURE, 95 - 42041 BRESCELLO (RE) ITALY				

(*) High temperature mode means 60°C on return and 80°C on flow. (**) Low temperature mode for condensation Boilers means 30°C, for low temperature boilers 37°C and for other appliances 50°C return temperature.

Efficiencies in the following tables refer to the gross calorific value.

Model/s:				ARES 350 TEC ErP				
Condensing Boilers:				YES				
Low temperature boiler:				NO				
Boiler type B1:				NO				
Co-generation appliance for central heating:				NO			Fitted with supplementary heating system:	NO
Combination heating appliance:				NO				
Element	Symbol	Value	Unit	Element	Symbol	Value	Unit	
Nominal heat output	P_n	342	kW	Seasonal energy efficiency of central heating	η_s	92	%	
For heating only boilers and combination boilers: useful heat output				For central heating only and combination boilers: effective efficiency				
At nominal heat output in high temperature mode (*)	P_4	341.7	kW	At nominal heat output in high temperature mode (*)	η_4	88.5	%	
At 30% of nominal heat output in a low temperature mode (**)	P_1	112.0	kW	At 30% of nominal heat output in a low temperature mode (**)	η_1	96.7	%	
Auxiliary electricity consumption				Other items				
At full load	el_{max}	0.507	kW	Heat loss in standby	P_{stby}	1.39	kW	
At partial load	el_{min}	0.040	kW	Ignition burner energy consumption	P_{ign}	1069	kW	
In standby mode	P_{SB}	0.010	kW	Emissions of nitrogen oxides	NO_x	54 (49)	mg / kWh	
For combination central heating appliances								
Stated load profile				Domestic hot water production efficiency		η_{WH}	%	
Daily electrical power consumption				Q_{elec}	kWh	Daily gas consumption		
Contact information				IMMERGAS S.p.A. VIA CISA LIGURE, 95 - 42041 BRESCELLO (RE) ITALY				

(*) High temperature mode means 60°C on return and 80°C on flow. (**) Low temperature mode for condensation Boilers means 30°C, for low temperature boilers 37°C and for other appliances 50°C return temperature.

Hydraulic Kits for hydraulic separator	
INAIL safety kit including circulator pump and hydraulic separator for 150 kW code 3.023645	INAIL safety kit including circulator pump and hydraulic separator for 200-250 kW code 3.023646
INAIL safety kit including circulator pump and hydraulic separator for 300-350 kW code 3.023647	INAIL safety kit including circulator pump and hydraulic separator for 440-770 kW code 3.023648
INAIL safety kit including circulator pump and hydraulic separator for 900 kW code 3.023649	INAIL safety kit with filter for 150-350 kW code 3.023656
INAIL safety kit with filter for 440-770 kW code 3.023657	INAIL safety kit with filter for 900 kW code 3.023658
Hydraulic separator kit for 150-350 kW code 3.023659	Hydraulic separator kit for 440-900 kW code 3.023660
External covering kit for INAIL kit and hydraulic separator of 150-350 kW code 3.023670	External covering kit for INAIL kit and hydraulic separator of 440-900 kW code 3.023671
Hydraulic Kits for plate heat exchanger	
INAIL safety kit including circulator pump and plate heat exchanger for 150-200 kW code 3.023650	INAIL safety kit including circulator pump and plate heat exchanger for 250-350 kW code 3.023651
INAIL safety kit including circulator pump and plate heat exchanger for 440-550 kW code 3.023652	INAIL safety kit including circulator pump and plate heat exchanger for 660 kW code 3.023653
INAIL safety kit including circulator pump and plate heat exchanger for 770 kW code 3.023654	INAIL safety kit including circulator pump and plate heat exchanger for 900 kW code 3.023655
External covering kit for INAIL kit and plate heat exchanger of 150-350 kW code 3.023672	External covering kit for INAIL kit and plate heat exchanger of 440-90 kW code 3.023673

ARES TEC ErP

Flue exhaust kit	
Rear flue exhaust kit Ø 150 for ARES 150-200 TEC ErP code 3.023701	Rear flue exhaust kit Ø 200 for ARES 250-300-350 TEC ErP code 3.023674
Side flue outlet support kit (for all models) code 3.023675	
Condensate drain management kit	
Condensate passivator kit up to 1500 kW (includes a complete granulate load) code 3.023662	Granulate kit for condensate passivator (25 kg) code 3.023663
Kit for temperature control	
SHC multifunction module kit (including 3 NTC probes) To integrate 3 additional user circuits for each module, up to a maximum of 4 modules (maximum 12 integration circuits). N.B.: One multifunction module (not connected) is standard supplied with the generator code 3.028338	Cascade and zone regulator kit (to manage up to 8 generators as a set) Made up from: HSCP display/programmer, BCM board, 24 V feeder, external probe, general flow probe, DHW storage probe. code 3.028340
24 V multifunction module feeder kit to install in the electrical panel code 3.028339	Temperature kit for solar collector code 1.028812

Règlement (UE) 2016/426 « Appareils à gaz »
Regulation (EU) 2016/426 « Gas appliances »

CERTIGAZ, atteste que les appareils mis sur le marché par la Société :
CERTIGAZ, attests that appliances marketed by :

ATTESTATION NUMERO 189M (rév.1)

IMMERGAS
Via Cisa Ligure, 95
I-42041 BRESCELLO (RE)

- **Genre de l'appareil** : CHAUDIERE A CONDENSATION
Kind of the appliance : (Types : B23P, C63)
CONDENSING BOILER
(Types : B23P, C63)

Marque commerciale et modèles <i>Trade mark and models</i>	Sont couverts par le certificat d'examen CE de type suivants <i>Are within the scope of subsequent EC type examination certificates</i>
IMMERGAS – ALPHA	1312BT5287 (rév.12)
<ul style="list-style-type: none"> ➤ ARES 150 Tec ErP ➤ ARES 200 Tec ErP ➤ ARES 250 Tec ErP ➤ ARES 300 Tec ErP ➤ ARES 350 Tec ErP 	

Pays de destination <i>Destination countries</i>	Pressions (mbar) <i>Pressures (mbar)</i>	Catégories <i>Categories</i>
FR	20/25 ; 37	I12Esi3P
ES-GB-IE-IT-PT-GR-SE-NO-SI	20 ; 37	I12H3P
AT-CH-TR-HR-CZ-SK	20 ; 50	I12H3P
CN-RU-RO-BG-LV-EE-LT	20	I2E
DE	20 ; 50	I12ELL3P
BE	20/25	I2E(R)
BE	37	I3P
HU	25 ; 50	I12HS3P
LU	20 ; 50	I12E3P
NL	20 ; 25 ; 50	I12L3P- I12EK3P
PL	20 ; 37	I12ELw3P

est conforme aux exigences essentielles du Règlement (UE) 2016/426 « Appareils à gaz ».
is in conformity with essential requirements of Regulation (EU) 2016/426 « Gas appliances »

Toute reproduction de ce certificat doit l'être dans son intégralité. Reproduction of this certificate must be in full. ½

Neuilly, le 20 août 2018

Le Directeur Général

Vincent DELARUE

Règlement (UE) 2016/426 « Appareils à gaz »
Regulation (EU) 2016/426 « Gas appliances »

CERTIGAZ, atteste que les appareils mis sur le marché par la Société :
CERTIGAZ, attests that appliances marketed by :

ATTESTATION NUMERO 194M (rév.1)

IMMERGAS
Via Cisa Ligure, 95
I-42041 BRESCELLO (RE)

- Genre de l'appareil : CHAUDIERE A CONDENSATION
Kind of the appliance : (Types : B23P, C63)
CONDENSING BOILER
(Types : B23P, C63)

Marque commerciale et modèles <i>Trade mark and models</i>	Sont couverts par les certificats d'examen CE de type suivants <i>Are within the scope of subsequent EC type examination certificates</i>
IMMERGAS – ALPHA	1312BS4959 (rév.13)
<ul style="list-style-type: none"> ➤ ARES 440 Tec ErP ➤ ARES 550 Tec ErP ➤ ARES 660 Tec ErP ➤ ARES 770 Tec ErP ➤ ARES 900 Tec ErP 	

Pays de destination <i>Destination countries</i>	Pressions (mbar) <i>Pressures (mbar)</i>	Catégories <i>Categories</i>
FR	20/25 ; 37	II2Esi3P
ES-GB-IE-IT-PT-GR-SE-NO-SI	20 ; 37	II2H3P
AT-CH-TR-HR-CZ-SK	20 ; 50	II2H3P
CN-RU-RO-BG-LV-EE-LT	20	I2E
DE	20 ; 50	II2ELL3P
BE	20/25	I2E(R)
BE	37	I3P
HU	25 ; 50	II2HS3P
LU	20 ; 50	II2E3P
NL	20 ; 25 ; 50	II2L3P- II2EK3P
PL	20 ; 37	II2ELw3P

est conforme aux exigences essentielles du Règlement (UE) 2016/426 « Appareils à gaz ».
is in conformity with essential requirements of Regulation (EU) 2016/426 « Gas appliances » ..

Toute reproduction de ce certificat doit l'être dans son intégralité. Reproduction of this certificate must be in full. 1/1

Le Directeur Général

Neuilly, le 20 août 2018

Vincent DELARUE

TEMPERATURE CONTROL APPENDIX

38 CONTROL PANEL

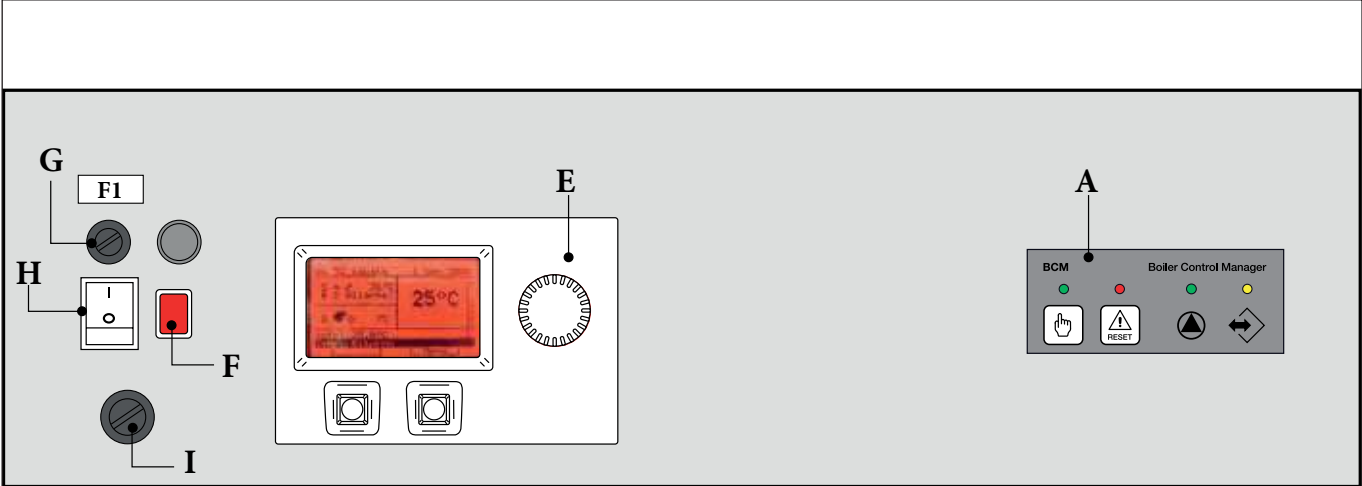

A	YELLOW LED = flashing (communication between BMM and BCM) ok GREEN LED = on (Pump On) RED LED = on (Error code detected)
E	“HSCP” boiler temperature control manager control panel
F	TLG General Limit Thermostat trigger light (not featured on models 150-200-250-300)
G	Fuses: 1 = 6.3 A
H	Main Switch
I	When TLG General Limit Thermostat comes on it cuts off power to the boiler and light F comes on; To re-arm it, take off the cap and press (this thermostat is not featured on models 150-200-250-300)

NOTE: the emergency function only switches the burners on in the boiler to 100% in flow. All system loads, including the manifold pump, must be controlled manually.

Access to the generator controls is extremely simple, by pushing the top cover, a perfect pneumatic system with gas shock absorbers lifts the waterproof generator cover, making the control panel accessible as shown in the picture above, additionally a safety lock screw prevents unwanted tampering. The ARES TEC ErP temperature control has been designed on two levels, represented by as many standard boiler devices: [HSCP] [Heating System Control Panel] and the "BCM" the boiler control board, the main features of which are described below. In addition to these, there are the management boards of the single elements [BMM].

A SHC [Slave Heating Controller] multifunction module is also supplied by standard with ARES TEC ErP. This is an integration P.C.B. to manage up to three user circuits, such as: solar circuits, combination zones, direct zones, additional DHW storage tanks, etc... The multifunction module takes control of the user circuits in addition to the circuits managed by the boiler control board [BCM] (the multifunction module is usually installed in an electrical panel in DIN template). For cascade applications, it is possible to use the cascade and zone regulator kit (optional) able to manage up to 8 generators in a set.

ARES TEC ErP

“HSCP” boiler temperature controller-manager

Retractable front control panel [HSCP] able to weekly program the operating times of the system circuits (up to a maximum of 12 independent system circuits).

The clear graphic design simplifies instantly selecting the screen of interest, directly accessing the menu functions divided into categories (Heating, DHW, Burners etc.) thanks to a knob and functional keys accompanied by a label that specifies their function in each single state of the generator use.

In addition to communicating with the boiler, thanks to its features, the boiler manager [HSCP] enables complete management of the thermal system, utilising the maximum achievable condensation and power modulation.

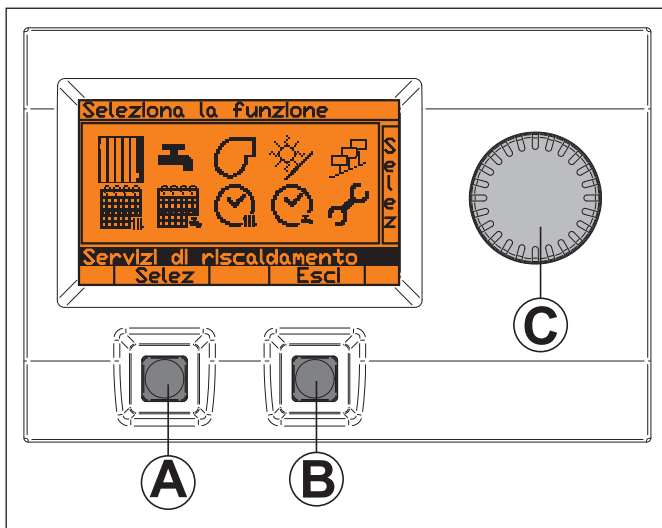

The request for heat can be generated by the [HSCP] temperature control/manager or alternatively by the [BCM] (Boiler Control Module).

The management logic requires simultaneous operation of the maximum number of possible heating elements to always achieve maximum possible performance, as long as the maximum exchange surface is in fact assured based on the delivered power. The elements are made to operate so as to equally divide the operating time.

It acts as a clear, simple and flexible dialog box to automatically detect and connect multiple devices between them; in fact for more complex systems it is possible to add the multifunction module [SHC] to manage areas (one is already provided by standard).

Therefore it manages the system's request (requests from active zones and sliding temperature operation).

Programming:

Program settings

The schedules can be set daily or weekly.

3 time slots in a day, each one associated to a different temperature;

Memorising up to 5 daily programs for heating and up to 3 daily programs for the D.H.W.

Weekly programming up to 3 programs for heating and likewise for the D.H.W.

Additional functions: holidays, climatic curves for each heating circuit, system status info, chimney sweep function.

System optimisation functions:

Overheating

Control of the generator safety temperature is assured through post-operation of the pumps in order to process any thermal inertia.

Boiler timer optimisation

Boiler temperature optimisation or central heating curve gradient.

Number of burner ignitions

This balances the number of ignitions for each burner of each single element.

Burner operation time

This balances the operating hours of each burner.

Antifreeze protection

This prevents, via automatic heating cycle, the system from freezing.

If the flow temperature (measured at the global flow) should fall below 7°C the system pump starts operating.

If the temperature drops any further (under 3°C), all modules will operate at the minimum power until the return temperature reaches 10 °C.

Parallel pump operation.

The possibility of keeping the heating pumps running, even during DHW production.

Domestic Hot Water Management:

DHW production

Various programs manage D.H.W. water production. You can opt from maximum comfort to maximum economy. For rapid storage tank set-up, the temperature control brings the boiler temperature to the maximum set value.

Anti-legionella.

60°C heating of storage tank temperature every 20 heating cycles or at least once per week on Saturday at 1am. This procedure eliminates any pathogen elements that may develop in the D.H.W. storage tank.

Renewable energy management:

The manager has a specific parameter setting section for integration with renewable energy systems such as solar systems.

“BCM” management board.

The “BCM” management board is used to:

- acquire information regarding the outside temperature;
- manage the modulating pump (0-10 V analogue output) with significant increase in performance at low loads;
- manage the start up of a pump (primary circuit) at a fixed speed from the control relay;
- manage the start-up of a pump (secondary circuit) at a fixed speed from the control relay for a direct zone;
- manage the start-up of a pump at a fixed speed from the control relay;
- have a back-up control unit available in case of anomalies on the main control unit [HSCP], thus preventing the system from shutting down;
- providing double safety of operation (emergency activation in the event of [HSCP] boiler control panel fault with request command at selectable temperature, with maximum power of 100%;
- manage and reset alarms (usable in addition to the Reset on the [HSCP]);
- remotely send alarms via relay;
- monitor the system’s operating status through remote management system (via Modbus).

“SHC” multifunction board.

The multifunction module takes control of the user circuits in addition to the circuits managed by the boiler control board [BCM] (the multifunction module is usually installed in an electrical panel in DIN template).

Each module can control up to 3 user circuits; if other services (storage tanks, mixed zones, solar, etc.) are requested, it is possible to set up additional SHC multifunction modules [SHC] (optional) to connect to the local bus for complete management via [HSCP].

It is possible to combine up to a maximum of 4 modules [SHC] to the HSCP control panel (1 supplied as standard - 3 to be provided as optional).

By connecting 4 boards [SHC], it is possible to manage up to 12 different user circuits, for example:

- Direct or mixed central heating circuits;
- Circuits for the production of DHW with DHW storage;
- Circuits for the production of DHW with plate heat exchanger;
- Circuits for the production of DHW with plate heat exchanger and mixing valve;
- Circuits for the production of DHW via mono or multilayer solar heating;

The main possible system configurations are those reported in the chapter “Examples of hydraulic application diagrams”.

ARES TEC ErP

Connection TA (*)

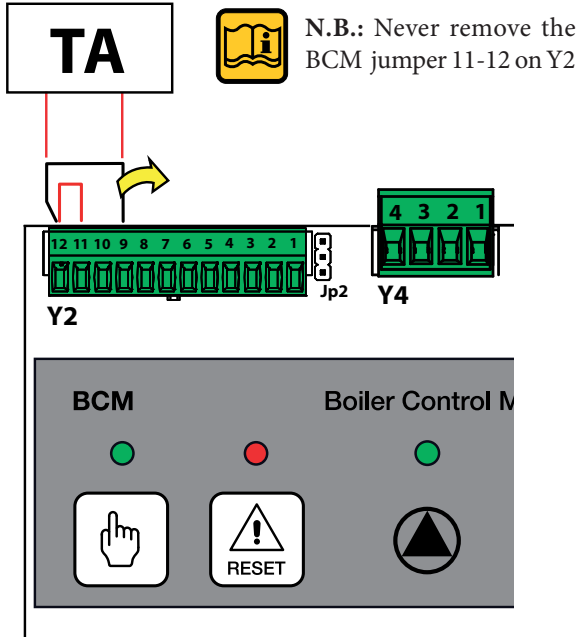

- (Y2 - 9 and terminal board M2) after removing the jumper (*) Optional

External probe connection

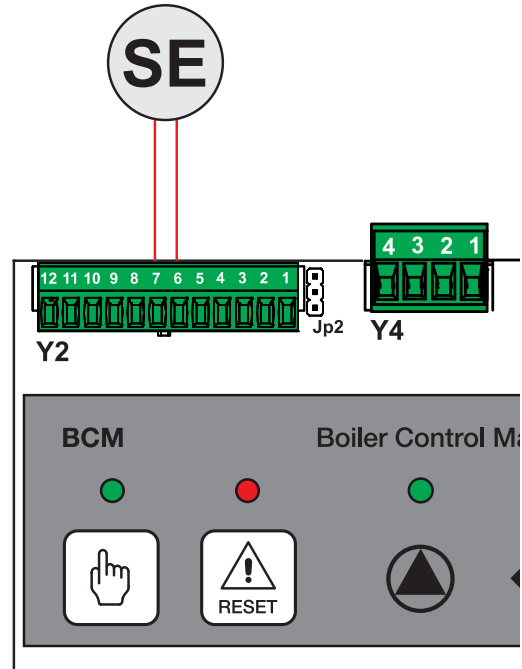

- Set up on the terminal board (Y2 6-7)

INAIL safety connection



FL Flow switch connection



NOTE: The BCM relay contacts support pumps with max absorption of 4 A.

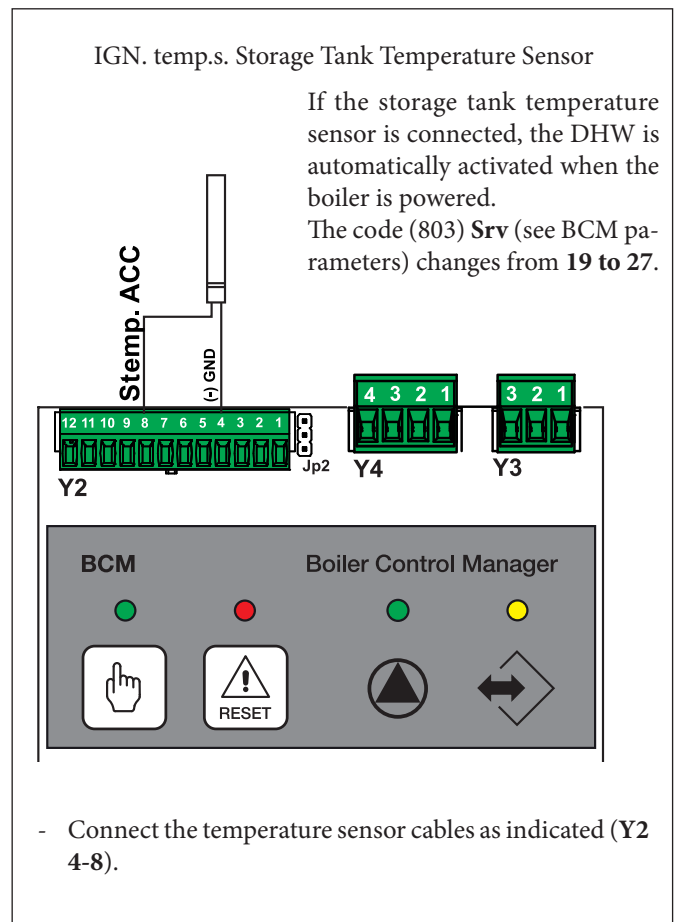
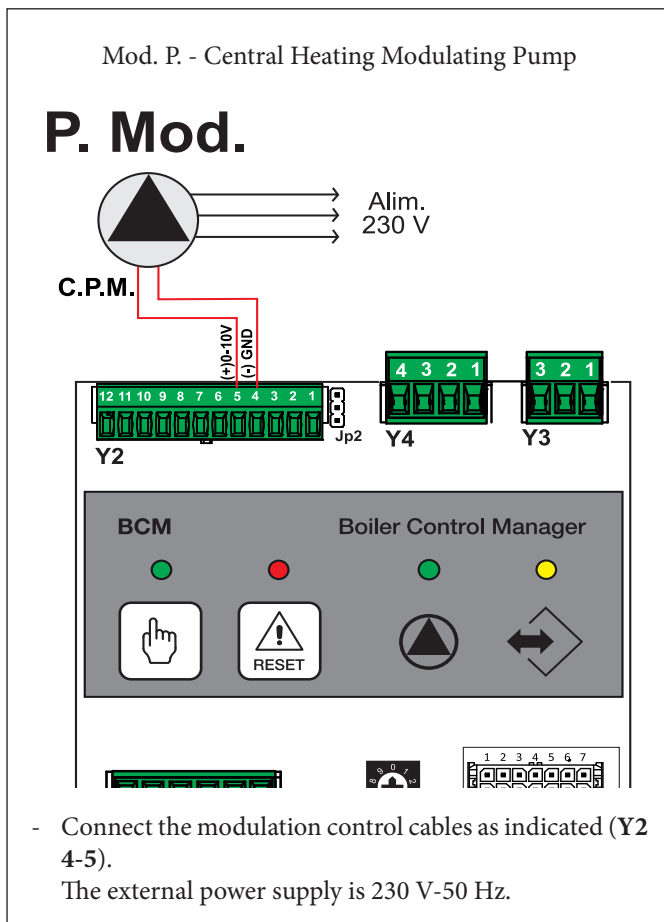
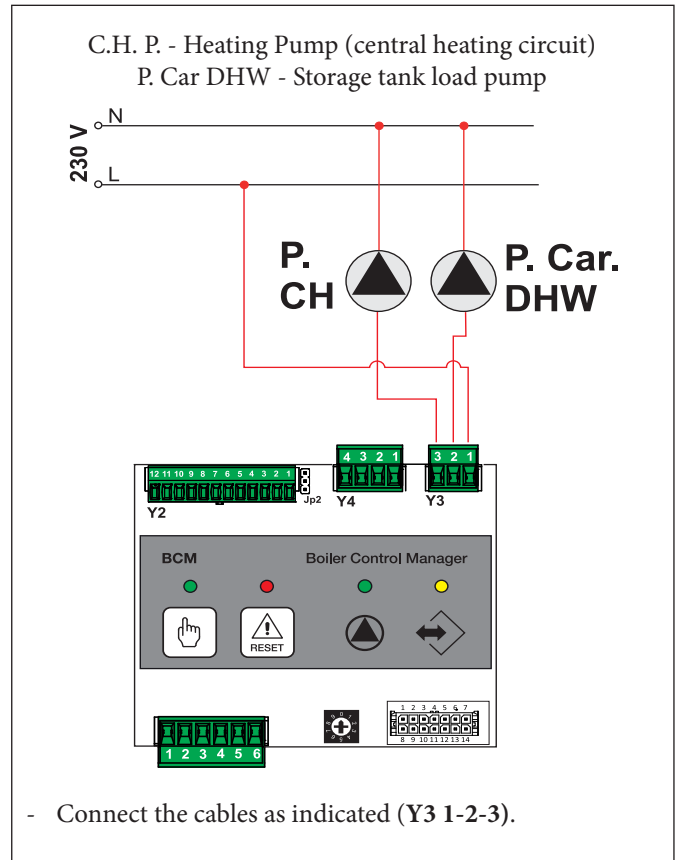
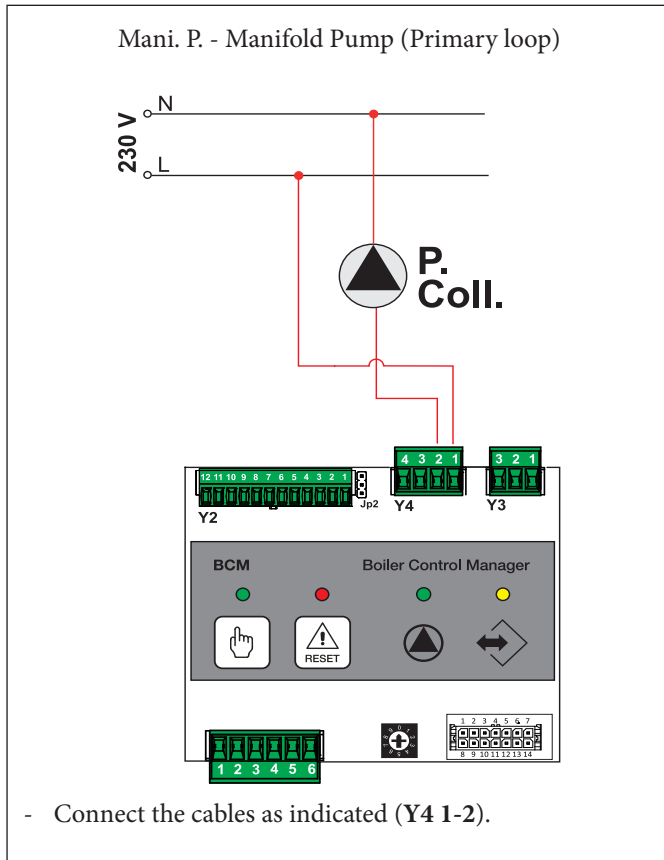

ARES TEC ErP

39

CASCADE REGULATOR KIT (CODE 3.028340)

By adding the cascade regulator kit, from 2 to 8 ARES TEC ErP can be managed through simple connections.

The connection is set up with BUS cables, according to the simplified diagram shown below.

The cascade and zone regulator manages the generators so that they work offering the best performance, as the power varies.

The cascade and zone regulator kit includes the external cascade control BCM board, HSCP display/programmer, 24 V feeder, general flow probe, DHW storage probe and external probe.

As optional kits, it is necessary to provide an INAIL safety kit for each generator.

The external HSCP acts as manager on the standard BCM on each boiler; when the external BCM is connected, it is then necessary to manage the system circuits with the same external BCM (1 common flow probe + 1 DHW storage probe) and possibly with the SHC (max 4 connectable SHC boards).

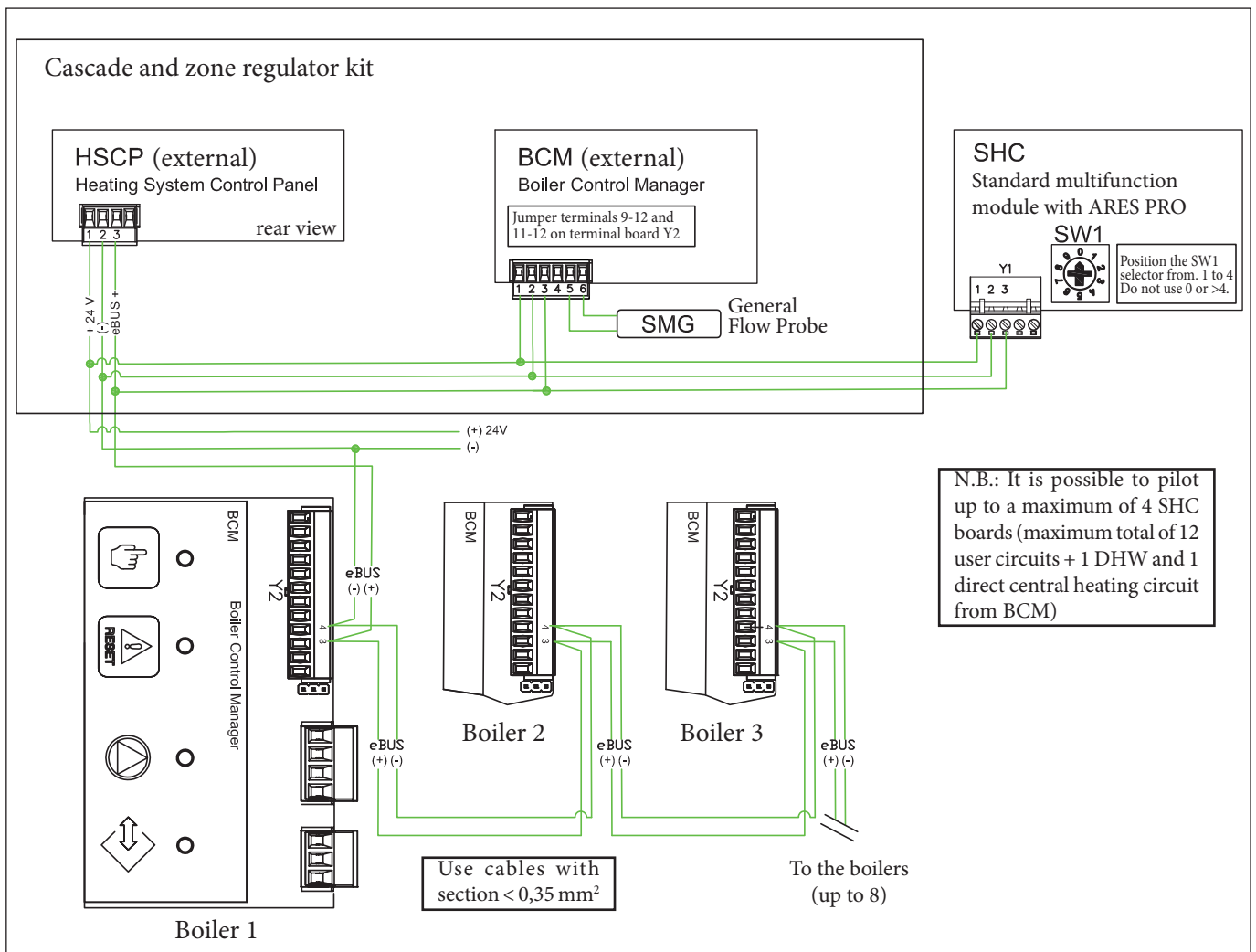

NOTE: Position the SW1 selectors of each BCM of each boiler as indicated:

Boiler 1 - Position 0

Boiler 2 - Position 1

Boiler 3 - Position 2

etc...

On the HSCP panel of the individual boilers, select the HCM device (BCM) from the menu and edit parameter 803 (Srv "Services Enabled") by setting the new value of "16".

The INAIL safety of each generator must be connected on the BCM of the generator itself, not on the external BCM, according to the diagram on page 45.

Electrical connection in a set of 2 ARES TEC ErP managed by the cascade regulator kit.

PRIMARY LOOP

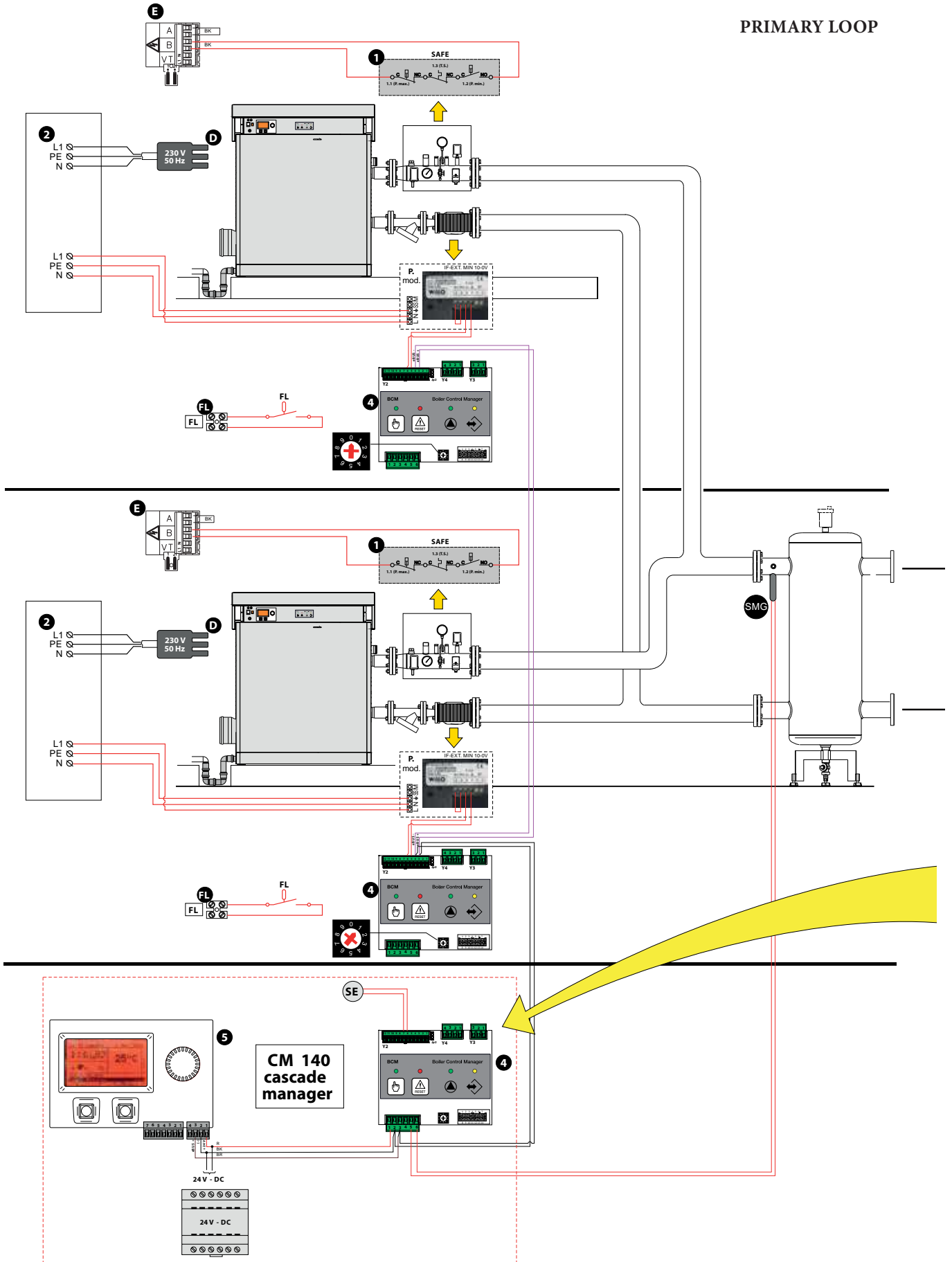

ARES TEC ErP

SECONDARY LOOP

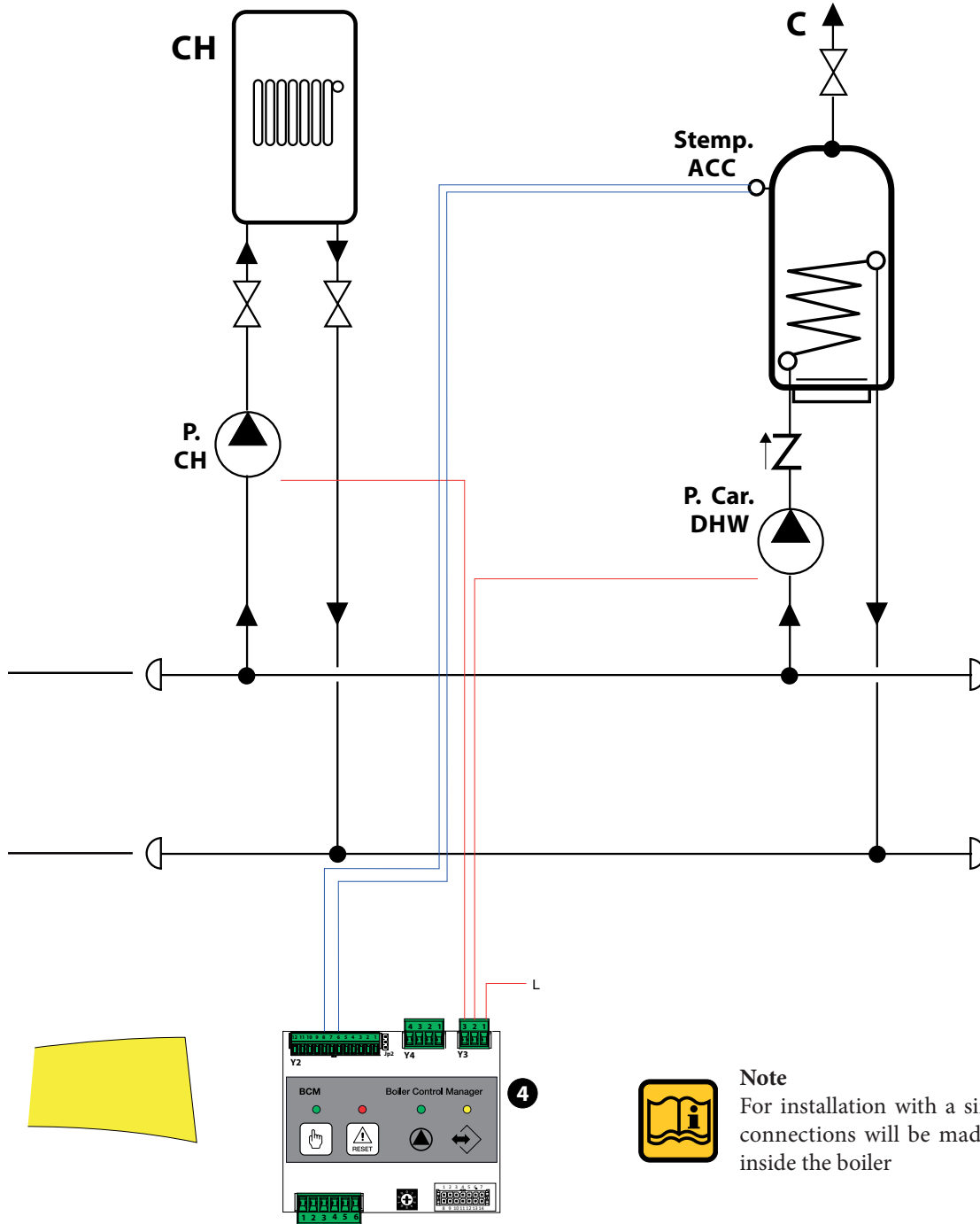

Note
For installation with a single boiler, the above connections will be made on the BCM board inside the boiler



Note
For configuration of boiler cascade management parameters, see the specific installation manual



Note
Example diagram, consider the total nominal flow rate, any non-return valves (not supplied), moreover, the efficiency of the flow switches must be checked at each flow rate in modulation

Communication via MODBUS RTU can be used to transmit data to the outside: in this sense, Immergas can provide the list of addresses to be used.

- file with HSCP addresses;
- file with BCM addresses;
- file with SHC addresses.

This offers full remote control of the generator, displaying all information:

- acquisition of operating info of all connected devices;
- setting/editing of parameters of each module;
- diagnostics management – alarm acquisition and reset.

ARES TEC ErP

Foreword:

The following pages provide examples (not exhaustive) of some of the most common configurations that can be set up with ARES TEC ErP.

The diagrams provided here are not working drawings and only serve the purpose of describing in a simplified manner the hydraulic and/or electric operation of the system and its connections; this overview of system engineering applications does not provide a solution for all of the practical case studies that can be implemented, nor does it assume that the illustrated examples cannot be modified; it serves as a valid guideline.

Each system needs to be accurately sized by a professional. Immergas will not be held liable for the failure to have a certified engineer inspect the project, who is also required to practice with good technique and in accordance with regulations in force.

Depending on the specific design and installation conditions, the diagrams and drawings provided in this documentation can require further integration or modifications, according to what is set forth by the Standards and technical regulations in force and applicable (as an example, the R stamp - edition 2009 is mentioned), in addition these generators compulsorily implicate the presence of a hydraulic separator or, alternatively, a plate heat exchanger.

It is the professional's responsibility to identify the applicable provisions, to evaluate compliance with these in each case and the necessity of any changes to diagrams and drawings.

To make them easier to read, the main hydraulic diagrams of the possible configurations are shown and reported.

The professional will still have to define the components required to develop the project, depending on the specific installation desired.

Specifically, the following pages show the following diagrams:

- 1) Diagram of system with 2 combination zones
- 2) Diagram of system with 3 direct zones
- 3) Diagram of system with 2 direct zones and 1 combination zone
- 4) Diagram of system with 1 combination zone, 1 direct zone and 1 DHW tank
- 5) Diagram of system with 1 direct zone and 1 combination DHW tank
- 6) Diagram of system with 2 direct zones and 1 DHW tank
- 7) Diagram of system with 2 direct zones, 1 DHW tank and 1 alarm
- 8) Diagram of system with solar field with storage tank, 1 direct zone and 1 DHW tank
- 9) Diagram of system with 2 solar fields with storage tank, 1 direct zone and 1 DHW tank
- 10) Diagram of system with 2 solar fields with storage tank and 1 combination DHW tank
- 11) Diagram of system with 3 DHW tanks
- 12) Diagram of system with 1 direct zone, 1 combination zone, 1 DHW tank and 1 alarm

The boiler is supplied as standard with the set-up to manage a direct flow and a storage tank through the BCM (it also performs the backup control unit function, i.e. in case of HSCP failure, it takes control of the generator, ensuring an emergency operation at fixed flow temperature, which is preconfigured from the beginning on the HSCP, then the setting resides in the BCM; but all power remains available).

If other services (storage tanks, combination zones, solar, etc.) are requested, it is possible to use SHC multifunction modules (one is standard with ARES TEC ErP, to be installed/connected if necessary) to connect to the local bus for total management via HSCP. Each SHC board controls up to 3 user circuits.

When the SHCs are connected, they take control over the user circuits (in addition to the circuits already managed by the BCM). It is possible to pilot up to a maximum of 4 SHC boards, 3 optional + 1 standard supplied with ARES TEC ErP (max total of 12 user circuits + 1 DHW and one direct central heating circuit managed by the BCM).

NOTE FOR ALL DIAGRAMS:

The St parameter selects the services provided by the multifunction module to adapt it to the user circuit needs. If there are 4 SHC, each can be configured differently from the others with the St parameter.

It is possible to use the complete diagram or only part of it; there is an additional parameter (Srv) to enable only the services that are actually used (e.g. only one zone instead of two).

For further information on the set-up and settings of the systems, please contact the Immergas Customer Service.

41 EXAMPLES OF HYDRAULIC APPLICATION DIAGRAMS

1) Diagram of system with 2 mixed zones

parameter **St 0**

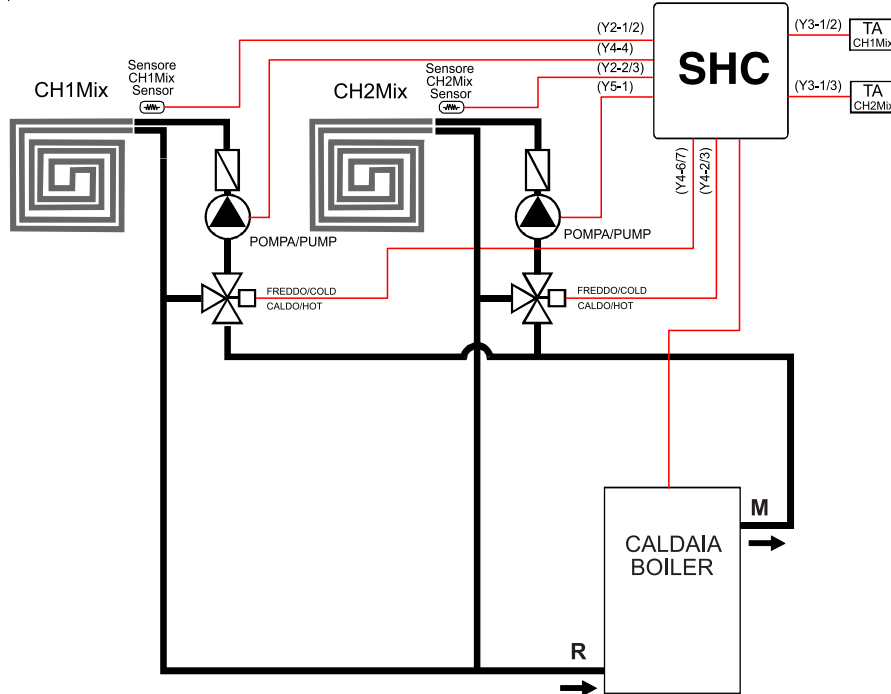

2) Diagram of system with 3 direct zones

parameter **St 4**

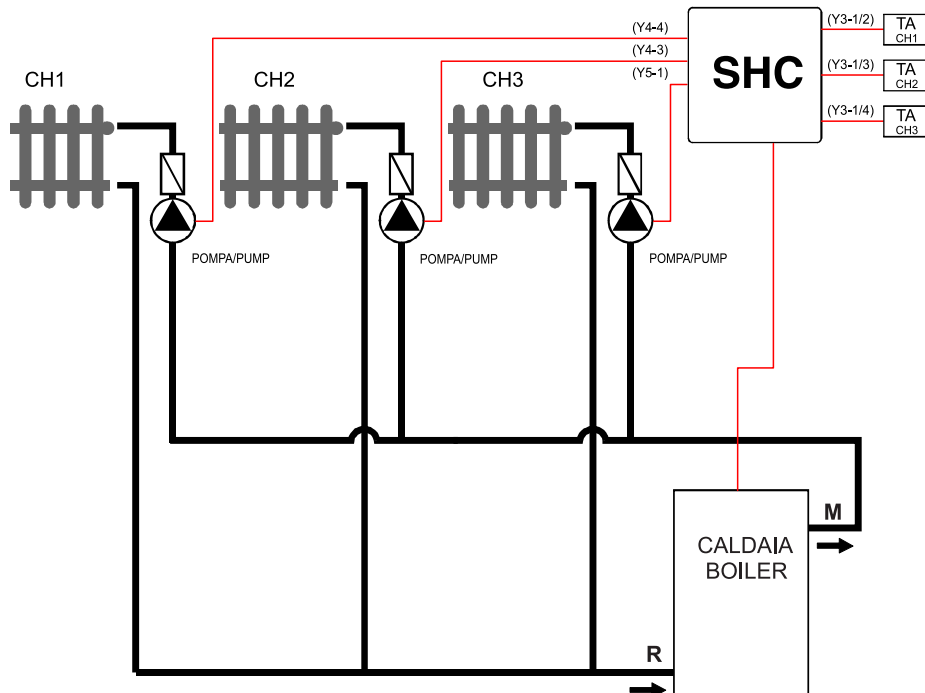

ARES TEC ErP

3) Diagram of system with 2 direct zones and 1 mixed zone

parameter **St 5**

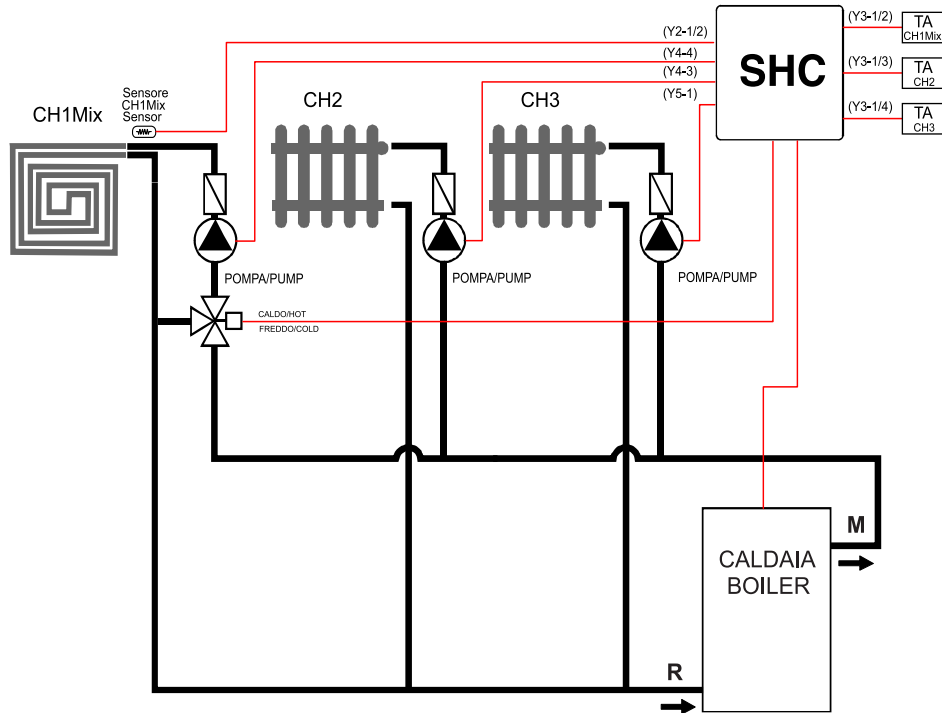

4) Diagram of system with 1 mixed zone, 1 direct zone and 1 DHW tank

parameter **St 6**

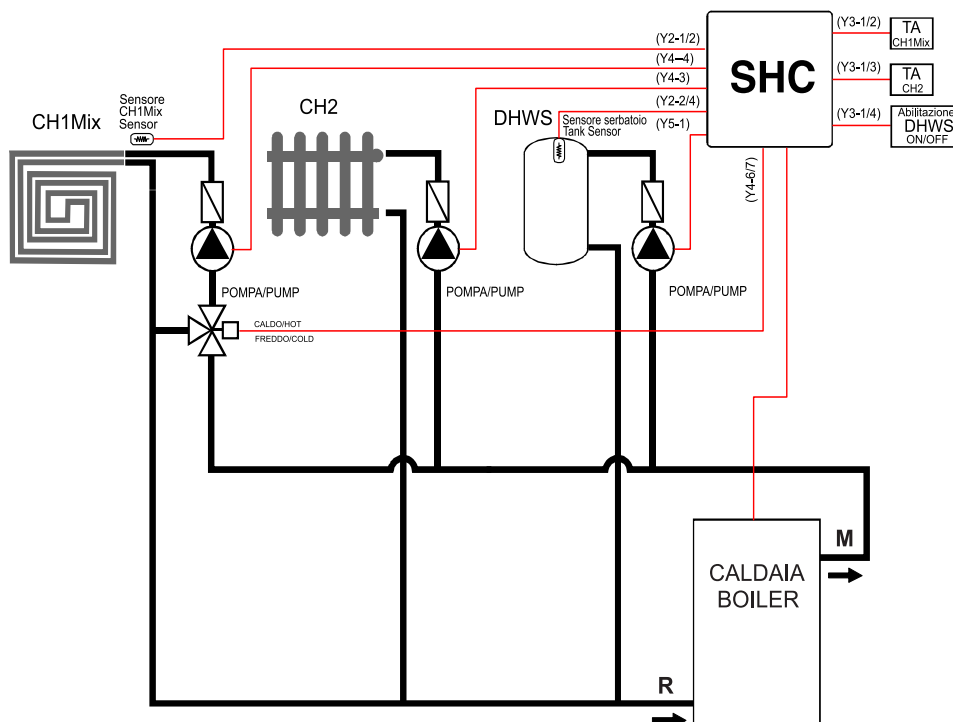

5) Diagram of system with 1 direct zone and 1 mixed DHW tank

parameter **St 7**

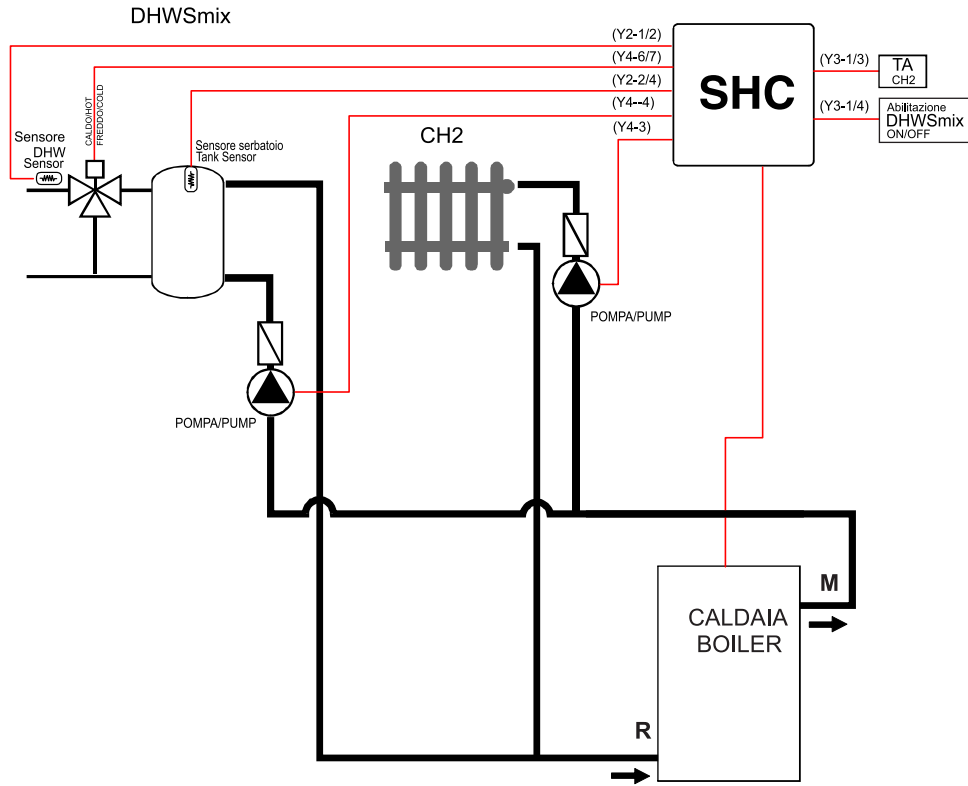

6) Diagram of system with 2 direct zones and 1 DHW tank

parameter **St 9**

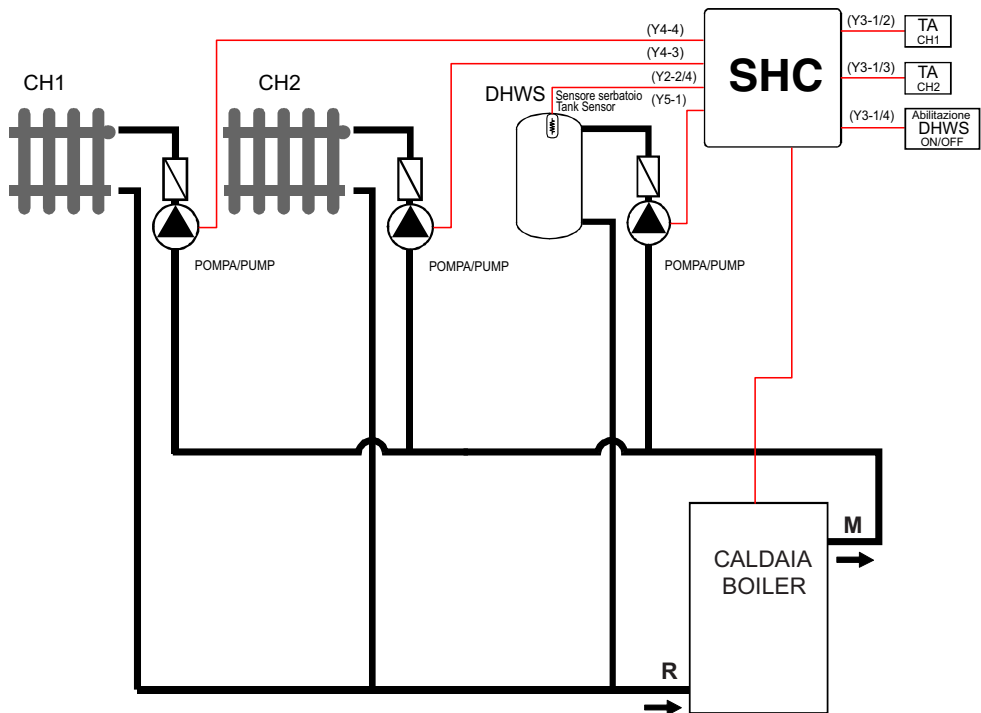

ARES TEC ErP

7) Diagram of system with 2 direct zones, 1 DHW tank and 1 alarm

parameter **St 10**

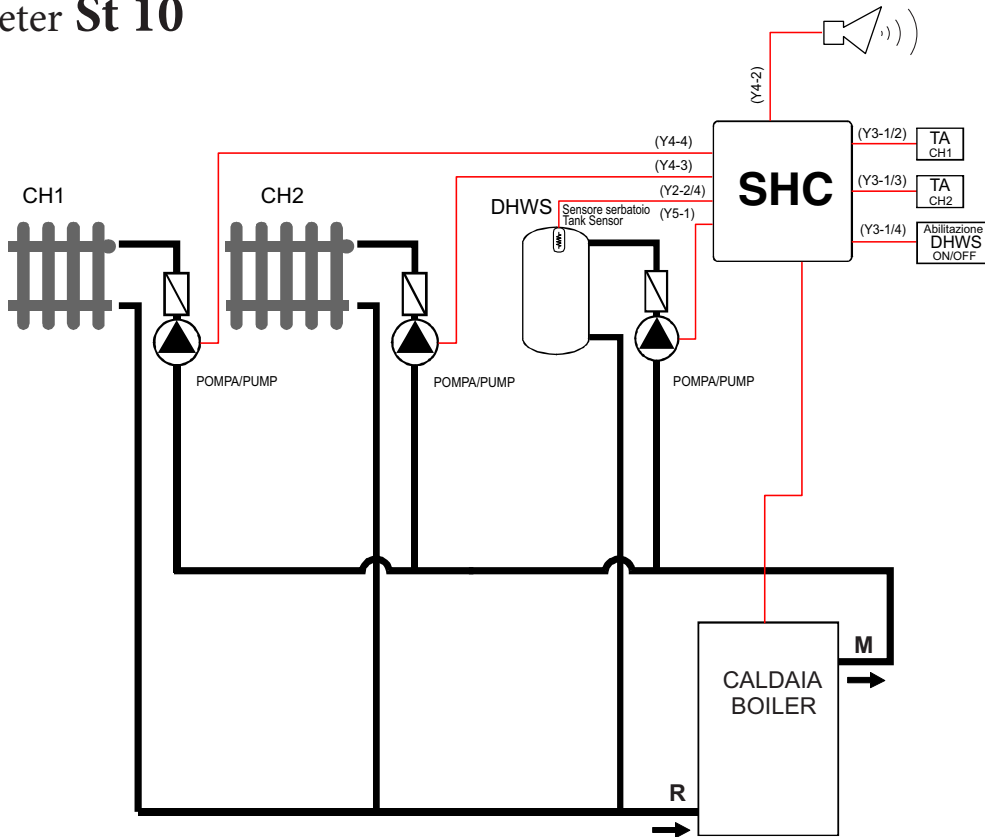

8) Diagram of system with solar field with storage tank, 1 direct zone and 1 DHW tank

parameter **St 13**

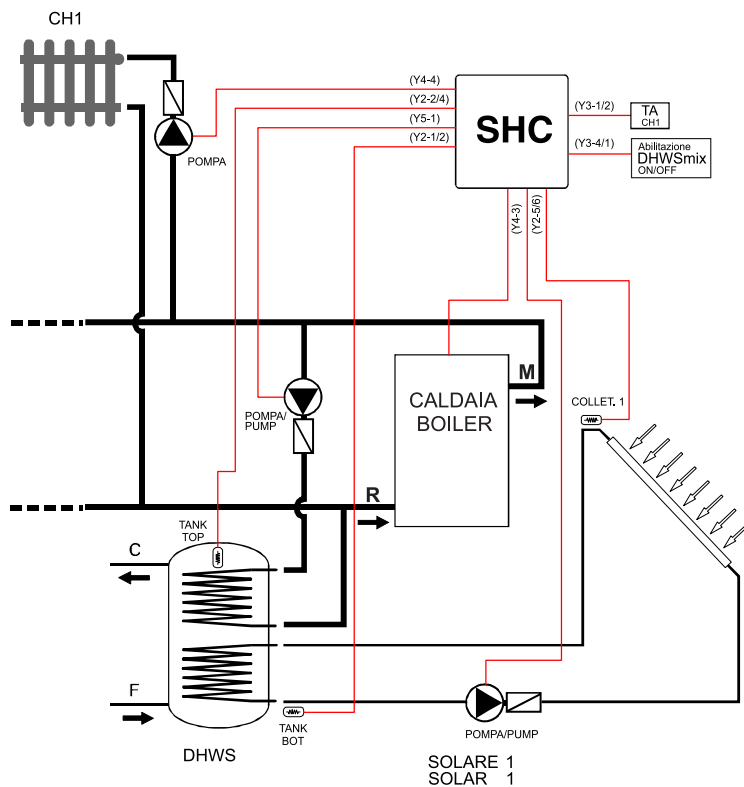

9) Diagram of system with 2 solar fields with storage tank, 1 direct zone and 1 DHW tank

parameter **St 14**

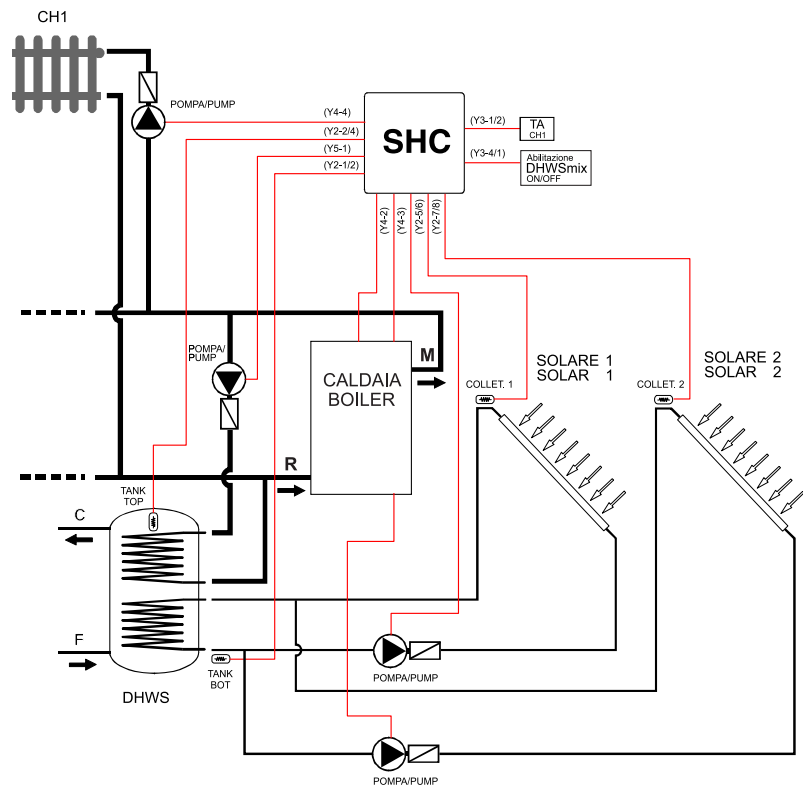

10) Diagram of system with 2 solar fields with storage tank and 1 mixed DHW tank

parameter **St 16**

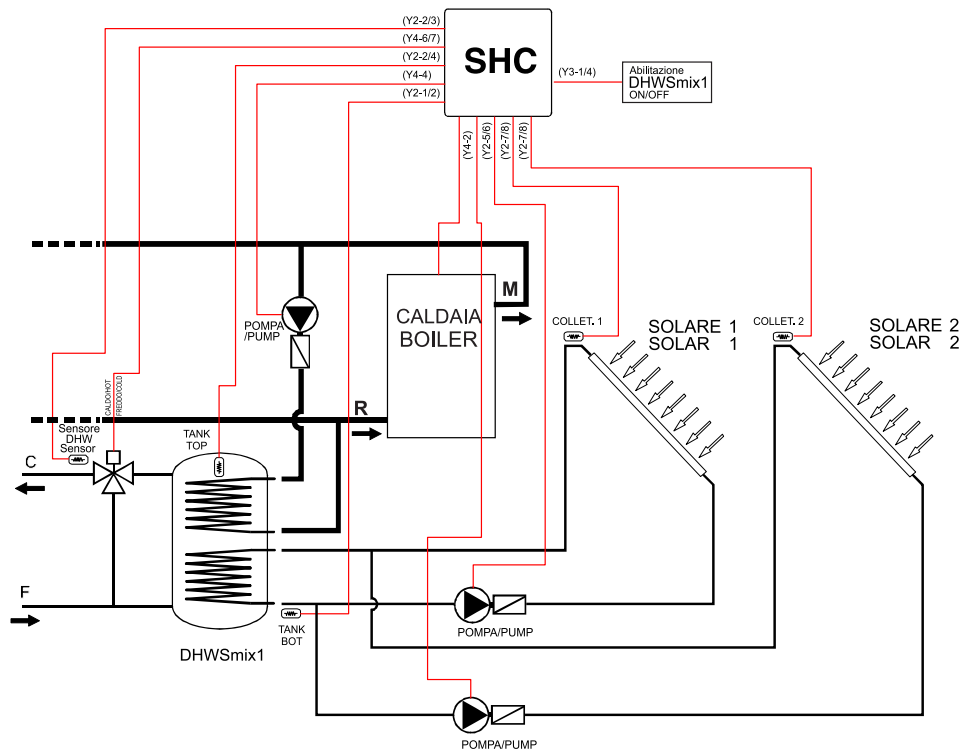

ARES TEC ErP

11) Diagram of system with 3 DHW tanks

parameter St 18

Note:

If less than 3 D.H.W. storage tanks are installed, connect:

in case of one tank => DHWS

in case of two tanks => DHWS+DHWS1

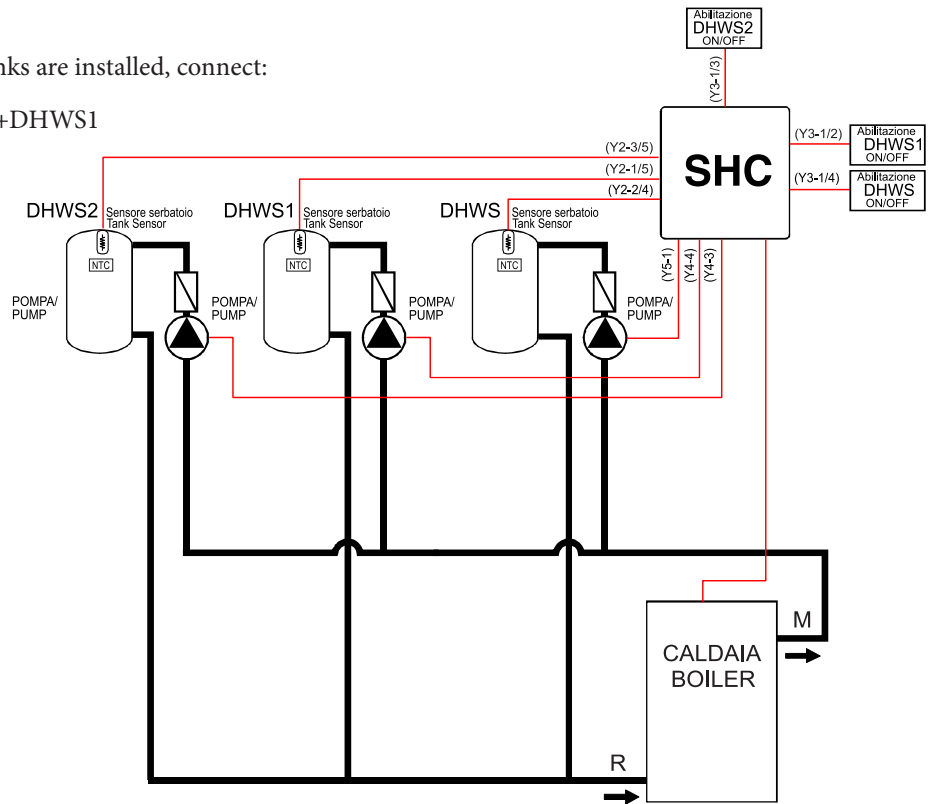

12) Diagram of system with 1 direct zone, 1 mixed zone, 1 DHW tank and 1 alarm

parameter St 19

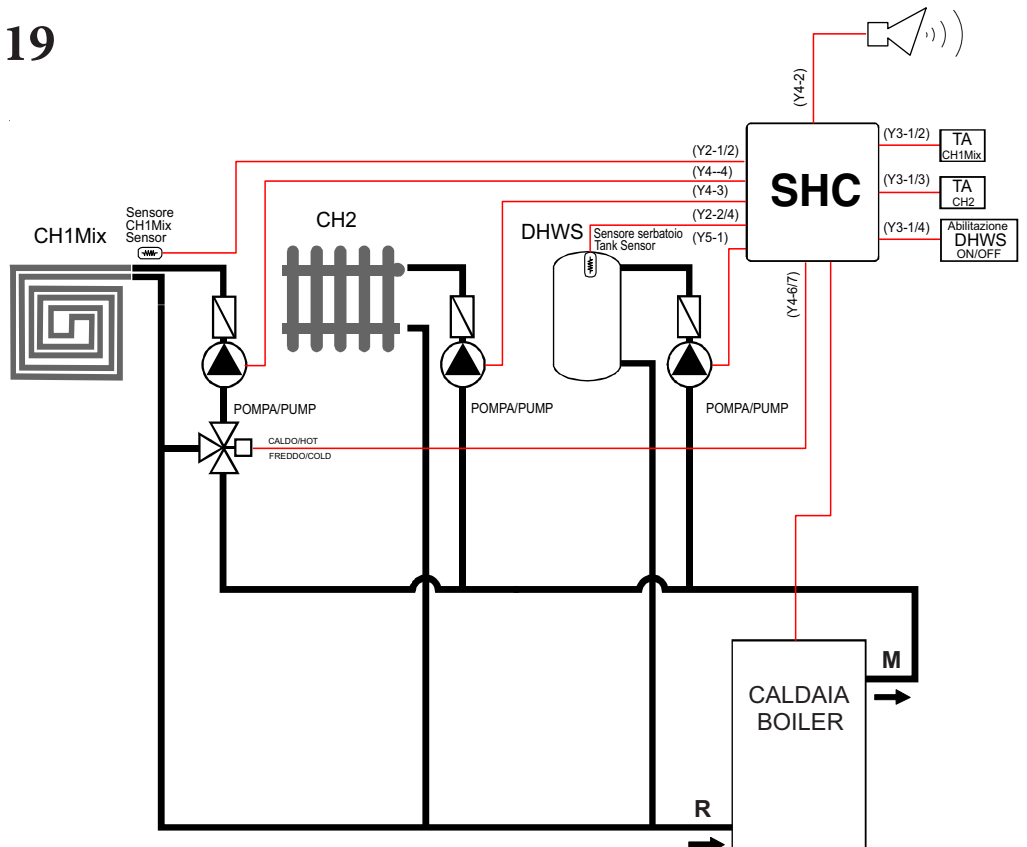

During the useful life of the products, performance is affected by external factors, e.g. the hardness of the DHW, atmospheric agents, deposits in the system and so on.

The declared data refer to new products that are correctly installed and used in observance of the Standards in force.

N.B.: correct periodic maintenance is highly recommended.

NOTE: Depending on the specific design and installation conditions, the diagrams and drawings provided in this documentation can require further integration or modifications, according to what is set forth by the Standards and technical regulations in force and applicable (as an example, the R stamp - edition 2009 is mentioned). It is the professional's responsibility to identify the applicable provisions, to evaluate compliance with these in each case and the necessity of any changes to diagrams and drawings.



Immergas TOOLBOX

L'App studiata da Immergas per i professionisti



immergas.com

Per richiedere ulteriori approfondimenti specifici, i Professionisti del settore possono anche avvalersi dell'indirizzo e-mail: consulenza@immergas.com

Immergas S.p.A.
42041 Brescello (RE) - Italy
Tel. 0522.689011
Fax 0522.680617



IMMERGAS
SISTEMA DI QUALITÀ
CERTIFICATO
UNI EN ISO 9001:2008

Progettazione, fabbricazione ed assistenza post-vendita di caldaie a gas, scaldabagni a gas e relativi accessori

