

MA  
SERIES  
USERS

Instructions and warnings **IE**

 **IMMERGAS**

# MAGIS M4-30

Block heat pumps  
Use and Installation

\*1.046978ENG\*





## **Dear Customer,**

*Congratulations for having chosen a top-quality Immergas product, able to assure well-being and safety for a long period of time. As an Immergas customer you can also count on a Qualified Authorised After-Sales Technical Assistance Centre, prepared and updated to guarantee constant efficiency of your appliance. Read the following pages carefully: you will be able to draw useful tips on the proper use of the device, compliance with which will confirm your satisfaction with the Immergas product. For assistance and routine maintenance, contact Authorised Technical Service Centres: they have original spare parts and are specifically trained directly by the manufacturer.*

## **General warnings**

*All Immergas products are protected with suitable transport packaging.*

*The material must be stored in a dry place protected from the weather.*

*The instruction booklet is an integral and essential part of the product and must be given to the new user in the case of transfer or succession of ownership.*

*It must be stored with care and consulted carefully, as all of the warnings provide important safety indications for installation, use and maintenance stages.*

*This instruction manual provides technical information for installing the Immergas pack. As for the other issues related to pack installation (e.g. safety in the work site, environment protection, injury prevention), it is necessary to comply with the provisions specified in the regulations in force and good practice rules.*

*In compliance with legislation in force, the systems must be designed by qualified professionals, within the dimensional limits established by the Law. Installation and maintenance must be performed in compliance with the regulations in force, according to the manufacturer's instructions and by professionally qualified staff, intended as staff with specific technical skills in the system sector, as envisioned by the Law.*

*Improper installation or assembly of the Immergas appliance and/or components, accessories, kits and devices can cause unexpected problems for people, animals and objects. Read the instructions provided with the product carefully to ensure proper installation.*

*Maintenance must be carried out by skilled technical staff. The Authorised After-Sales Service represents a guarantee in terms of qualifications and professionalism.*

*The appliance must only be destined for the use for which it has been expressly declared. Any other use will be considered improper and therefore potentially dangerous.*

*If errors occur during installation, operation and maintenance, due to non-compliance with technical laws in force, standards or instructions contained in this book (or however supplied by the manufacturer), the manufacturer is excluded from any contractual and extra-contractual liability for any damage and the appliance warranty is invalidated.*

The company **IMMERGAS S.p.A.**, with registered office in via Cisa Ligure 95 42041 Brescello (RE), declares that the design, manufacturing and after-sales assistance processes comply with the requirements of standard **UNI EN ISO 9001:2015**.

For further details on the product CE marking, request a copy of the Declaration of Conformity from the manufacturer, specifying the appliance model and the language of the country.

The manufacturer declines all liability due to printing or transcription errors, reserving the right to make any modifications to its technical and commercial documents without forewarning.

## INDEX

Introduction .....	5	9 Overview of the unit.....	49
1 General safety warnings.....	7	9.1 Disassembling the unit.....	49
2 General Introduction.....	11	9.2 Main components .....	50
3 Accessories.....	14	9.3 Electronic control box.....	52
3.1 Accessories supplied with the units 4-16 kw.....	14	9.4 Water pipes.....	69
3.2 Accessories supplied with the units 18-30 kw.....	15	9.5 Filling with water.....	74
4 Prior to installation.....	16	9.6 Water pipe insulation.....	75
5 Important information on the refrigerant.....	17	9.7 Wiring on field.....	75
6 Installation site.....	18	10 Start up and configuration.....	98
6.1 Selection of a cold weather location.....	21	10.1 Overview of dip switch settings.....	98
6.2 Selection of a hot weather location.....	21	10.2 Initial start-up at low outdoor temperatures.....	98
7 Installation precautions.....	22	10.3 Checks prior to operation.....	99
7.1 Dimensions.....	22	10.4 The circulation pump.....	99
7.2 Installation requirements.....	23	10.5 On-field settings.....	102
7.3 Position of drain hole.....	23	11 Test mode and final checks.....	120
7.4 Clearance requirements for maintenance.....	24	11.1 Final checks.....	120
7.5 Control Panel installation manual.....	26	11.2 Test operation (manual).....	120
8 Typical application examples.....	30	12 Maintenance and service.....	121
8.1 UNITS 4-16 KW: Application 1.....	30	13 Troubleshooting.....	122
8.2 UNITS 4-16 KW: Application 2.....	33	13.1 General guidelines.....	122
8.3 UNITS 4-16 KW: Cascade System.....	37	13.2 General symptoms.....	122
8.4 UNITS 18-30 KW: application 1.....	39	13.3 Operation parameters.....	124
8.5 UNITS 18-30 KW: Application 2.....	40	13.4 Error codes.....	125
8.6 UNITS 18-30 KW: Application 3.....	42	14 Technical specifications.....	132
8.7 UNITS 18-30 KW: Application 4.....	44	14.1 General.....	132
8.8 UNITS 18-30 KW: Application 5.....	46	14.2 Electrical technical specifications.....	133
8.9 UNITS 18-30 KW: Cascade system application.....	48	15 Information on maintenance.....	134
		15.1 Annexes - Refrigerant cycle.....	138

- *This manual provides a detailed explanation on the precautions to be taken during use.*
- *Read this manual carefully before using the wall-mounted control unit to guarantee its proper operation.*
- *After you have read this manual, keep it for future consultation.*



INTRODUCTION

Magis M 4/6

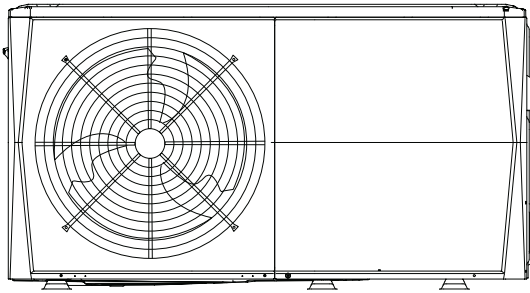

Magis M 8/12/14/16

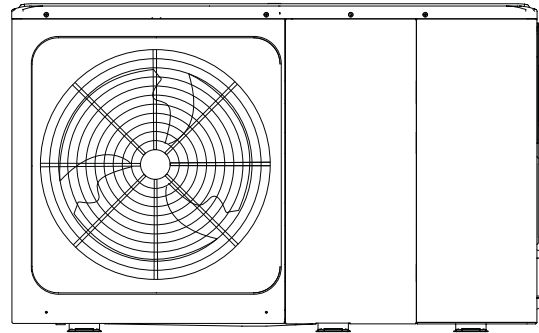

Internal arrangement: Magis M 12-16 T

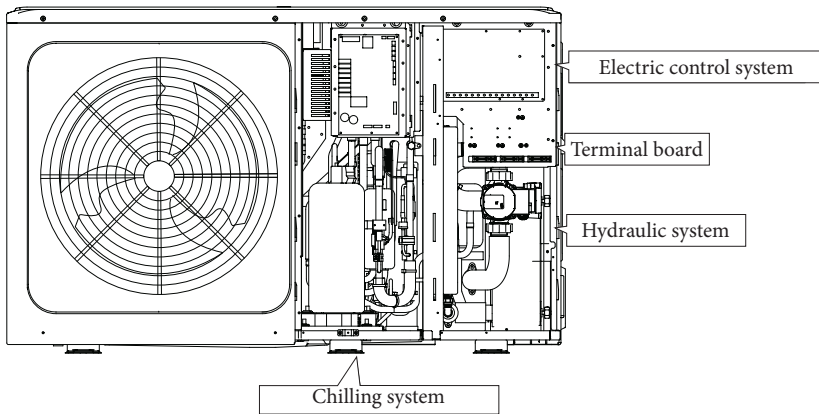

Please remove the protective panel after installation.

Magis M 4/6

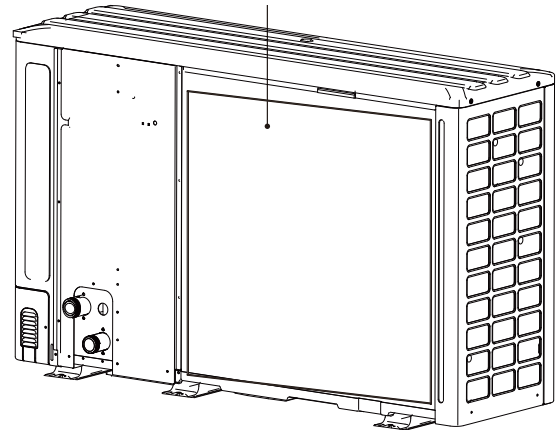
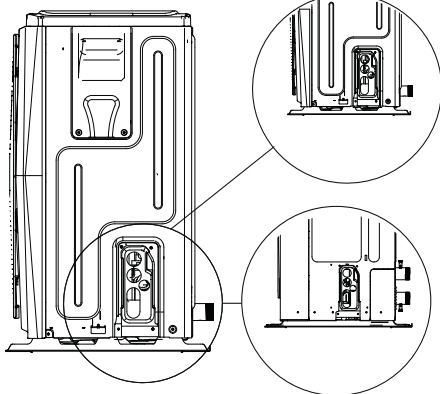

Magis M 8/12/14/16

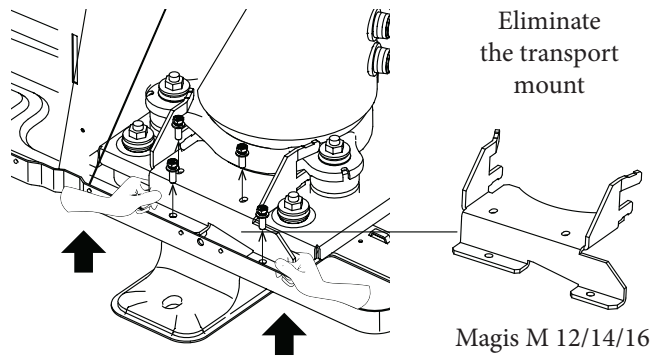

Magis M 18/22/26/30

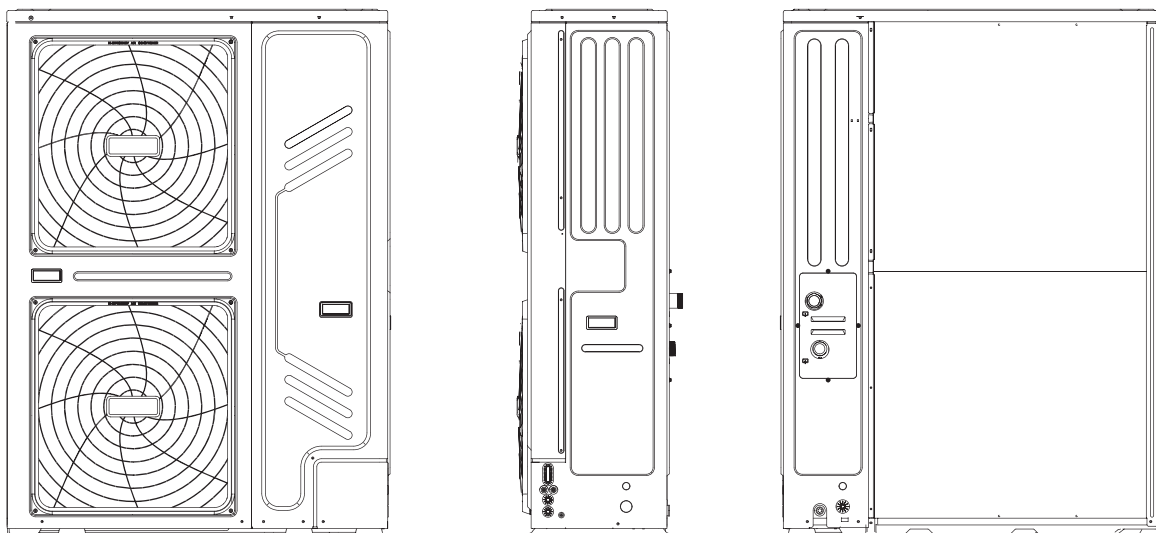

Wiring diagram

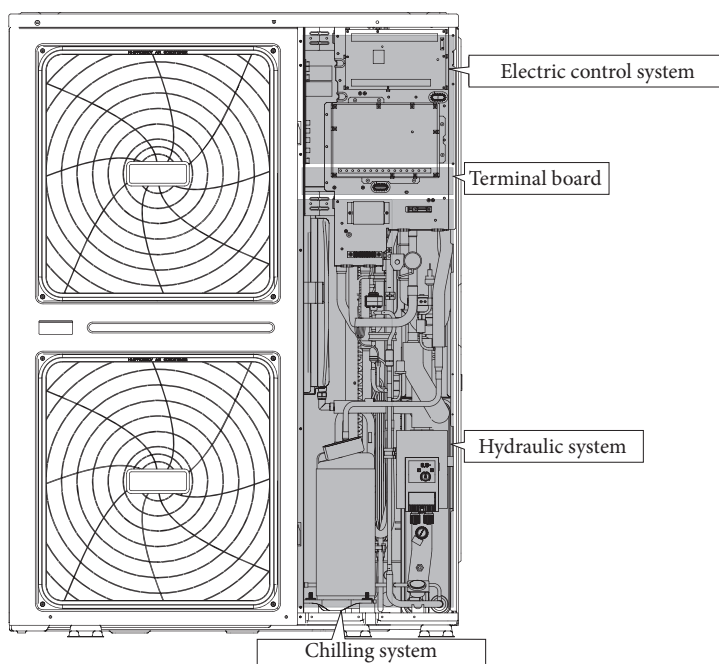

**NOTE**

The images in this manual are only used as a reference - refer to the actual product.

**NOTE**

- The maximum length of the wiring that guarantees communication between the heat pump and the control panel is 50 m.
- The power cables and communication wires are laid separately and cannot be placed in the same duct. Otherwise there would be electromagnetic interference. The power cables and wires for communication must not come into contact with the refrigerant pipe which at high temperatures could damage the wires.
- The communication wires must be in shielded lines, including the line that goes from the heat pump to the control panel.

# 1 GENERAL SAFETY WARNINGS.

The precautions listed below are divided into the following types. They are rather important and therefore must be followed carefully. Meaning of DANGER, WARNING, CAUTION and NOTE symbols.

## INFORMATION

- Improper installation of the appliances or accessories can cause electric shocks, short-circuits, leaks, fire or other damage to the equipment. Make sure to only use accessories made by the supplier, which are specifically designed for the appliance and make sure that installation is performed by a skilled professional.
- All of the tasks described in this manual must be carried out by an authorised technician. During installation of the unit or when carrying out maintenance, make sure to wear adequate personal protective equipment, such as safety gloves and goggles.
- Contact your dealer for any type of service intervention.



Caution: risk of fire/flammable materials

## WARNING

Maintenance must only be carried out according to the instructions given by the manufacturer of the appliance. Maintenance and repairs that require the assistance of other qualified personnel must be carried out under the supervision of a person capable of using flammable refrigerants.

## DANGER

Indicates a situation of imminent danger which, if not avoided, will cause death or serious injury.

## WARNING

Indicates a potentially hazardous situation which, if not avoided, could cause death or serious injury.





## CAUTION

Indicates a potentially hazardous situation which, if not avoided, can cause slight or moderate injury. It is also used to warn about unsafe practices.

## NOTE

Indicates a situation that could only result in equipment or property damage.

**Explanation of the symbols displayed on the unit.**

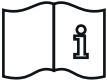
	WARNING	This symbol indicates that the appliance in question used a flammable refrigerant. There is a risk of fire if the refrigerant leaked or was exposed to an external ignition source.
	CAUTION	This symbol indicates to carefully read the user manual.
	CAUTION	This symbol indicates that service personnel must handle the appliance while referring to the installation manual
	CAUTION	This symbol indicates that service personnel must handle the appliance while referring to the installation manual
	CAUTION	This symbol indicates that there is information available such as instructions for use or installation instructions.

** DANGER**

- Please switch off the power switch before touching the components of the electric terminals.
- When the service panels are removed, it is easy to mistakenly touch live components.
- Never touch the unit during installation or maintenance with the service panel removed.
- Do not touch the water pipes during and immediately after operation as they could be hot and burn your hands. To avoid injury, allow the pipes to return to normal temperature or put on protective gloves.
- Do not touch any switch with wet fingers. Touching a switch with wet fingers could cause electric shocks.
- Switch off the unit before touching electric components.

## **WARNING**

- Tear up plastic packaging bags and throw them away so that children do not play with them. Children can risk dying by suffocation if they play with plastic bags.
- Safely dispose of packaging materials such as nails or other metal or wooden parts which could cause injury.
- Ask your dealer or qualified personnel to perform the installation jobs in compliance with this manual. Do not install the unit on your own. Improper installation could cause water leaks, electric shocks or fire.
- Make sure to use only the accessories and components specified for the installation jobs. Failure to use the specified components could cause water leaks, electric shocks, fire or cause the unit to fall off its stand.
- Install the unit on a foundation capable of bearing its weight. The appliance could fall or cause injury if not sufficiently stable.
- Perform the specified installation jobs taking into account strong winds, hurricanes or earthquakes. Improper installation could cause accidents due to the equipment falling.
- Make sure that all the electrical jobs are carried out by qualified personnel in compliance with local laws and regulations and with this manual, using a separate circuit. An insufficient capacity of the power circuit or an incorrect electrical system can cause electrical shocks and fire.
- Make sure to install a ground fault circuit interrupter in compliance with local laws and regulations. Failure to install a ground fault circuit interrupter can cause electrical shocks and fire.
- Check that all the cables are firm. Use the specified wires and check that the connections of the terminals or wires are protected against water and other outside adverse forces. An incomplete connection or fastening can cause a fire.
- When wiring the power supply, position the wires so that the front panel can be fixed safely. If the front panel is not in place, there could be overheating of terminals, electric shocks or fire.
- After having completed installation, make sure there are no refrigerant leaks.
- Never touch leaking refrigerant as it could cause frostbite. Do not touch the refrigerant pipes during and immediately after operation as the refrigerant inside could be hot or cold, depending on the conditions of the refrigerant flowing through the pipes, the compressor or the other parts of the refrigerant cycle. Touching the refrigerant pipes could cause burns or frostbite. To avoid injury, allow the pipes to return to normal temperature or, if you need to touch them, put on protective gloves.
- Do not touch the internal parts (pump, etc.) during and immediately after operation. Contact with internal parts can cause burns. To avoid injury, allow the internal components to return to normal temperature; otherwise, if you absolutely need to touch them, put on protective gloves.

## **CAUTION**

- Placed the unit on the ground.
- The earthing resistance must comply with local laws and regulations.
- Do not connect the earth cable to gas or water pipelines, to lightning rods or the earth cables of the telephone.
- Incomplete earthing can cause electric shocks.
  - Gas pipes: gas leaks could cause a fire or explosion.
  - Water pipes: rigid rubber hoses do not guarantee earthing.
  - Lightning rods: or telephone earthing wires: the electrical threshold could increase anomalously if struck by lightning.
- Install the power cable at least 1 m away from TVs and radios to avoid interference or noise. (Depending on the radio waves, a distance of 1 m might not be enough to eliminate noise).
- Do not use pressurised water without a large diffuser. Do not use high-pressure cleaners for Cu/Cu and Cu/Al air coils. Concentrated and/or rotating water jets are strictly prohibited. Never use fluid with a temperature above 45°C to clean the air heat exchangers. The device must be installed in compliance with the national wiring regulations. If the power cable is damaged, it must be replaced by the manufacturer, by a service agent or by just as qualified persons to avoid danger.

## CAUTION

- Do not install the unit in the following places:
  - Where there is mineral oil mist, oil spray or vapours. The plastic components could deteriorate and cause detachment or leakage of water.
  - Where corrosive gases are produced (such as sulphurous acid gas). Where the corrosion of copper pipes or welded parts can lead to refrigerant leaks.
  - Where there is machinery that emits electromagnetic waves. The electromagnetic waves can disturb the control system and cause the appliances to malfunction.
  - Where flammable gases could escape, where the carbon fibre or flammable dust is suspended in the air or where flammable volatile substances are handled such as paint thinners or petrol. These types of gas could cause a fire.
  - Where the air contains high levels of salt, like near the ocean.
  - Where there is high voltage isolation, like in factories.
  - In vehicles or ships.
  - Where there are acid vapours or alkalines.
- This appliance can be used by children at least 8 years old and by persons with reduced physical, sensory or mental capacities or with little experience and knowledge as long as they are supervised or receive instructions on how to use the appliance safely and understand its risks. Children should not play with the appliance. Cleaning and maintenance of the utility must not be carried out by children without supervision.
- Make sure that children do not use the product as a toy.
- If the power cable is damaged, it must be replaced by the manufacturer, by a service agent or by just as qualified persons.
- **DISPOSAL:** Do not dispose of this product as unsorted city waste. This waste must be collected separately for special treatment. Do not dispose of electrical equipment as city waste; make use of separate collection facilities. Contact your local government for information on available collection facilities. If the electrical equipment is disposed of in landfills, the hazardous substances can infiltrate into groundwater and enter the food chain, thus damaging your health and well-being.
- Check the safety of the area and installation (walls, floors, etc.) without concealed dangers such as water, electricity and gas.
- Before installation, check whether the power supply of the utility meets the electrical installation requirements of the unit (including reliable earthing, dispersion and the diameter of the electrical load cable, etc.). If the electrical installation requirements of the product are not met, the product cannot be installed until this is rectified.
- When several units are installed in a centralised manner, please confirm balancing of the three-phase power load and do not allow multiple units to be assembled in the same three-phase power supply phase.
- The installed product must be firmly fastened. Use reinforcement measures where necessary.
- To guarantee the safety of the product, please restart the unit at least once every 3 months so that it can perform a self-inspection.

## NOTE

- Information on fluorinated gases
  - This unit contains fluorinated gases. For specific information on the type and amount of gas, see the relative label on the unit. National standards on gas must be complied with.
  - Installation, service, maintenance and repair operations on this unit must be carried out by a certified technician.
  - The product must be uninstalled and recycled by a certified technician.
  - If the system is fitted with a leak detection system, it must be checked at least every 12 months. When a leak check is carried out on the unit, you are warmly recommended to correctly log all the controls.

## 2 GENERAL INTRODUCTION.

- Magis M4-30 block heat pumps are used both for heating and cooling applications and for domestic hot water tanks. They can be coupled with fan coils, floor heating applications, low-temperature high-efficiency radiators, domestic hot water tanks and solar kits.
- The unit is supplied with a control panel.

### NOTE

- The maximum length of the wiring that guarantees communication between the heat pump and the control panel is 50 m.
- The power cables and communication wires are laid separately and cannot be placed in the same duct. Otherwise there would be electromagnetic interference. The power cables and wires for communication must not come into contact with the refrigerant pipe which at high temperatures could damage the wires.
- The communication wires must be in shielded lines, including the line that goes from the heat pump to the control panel.

Models 4-30

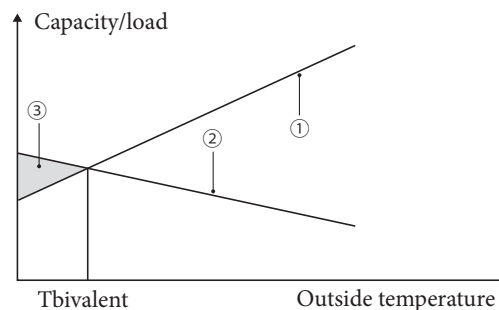

- 1) Heat pump capacity.
- 2) Required heating capacity (depending on site).
- 3) Additional heating capacity supplied by a backup heater.

### Domestic hot water tank (optional)

A domestic hot water storage tank can be connected to the unit (with or without tank booster heater (TBH))

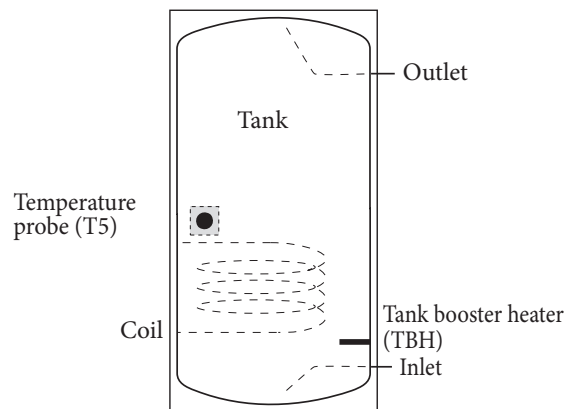

The tank booster heater (TBH) must be installed below the temperature probe (T5)

The heat exchanger (coil) must be installed below the temperature probe.

### Room thermostat (optional)

The room thermostat can be connected to the unit (the room thermostat must be far away from the heating source when the installation place is chosen).

### Solar kit (optional)

A solar kit can be connected to the appliance for the domestic hot water tank.

The unit has a freezing prevention function using the heat pump to keep the water system safe from freezing in all conditions. Since a power failure could occur while the unit is unattended, it is recommended to empty the system (if there is no glycol in the water). (Chap. 9.4.4 Anti-freeze protection of water circuit).



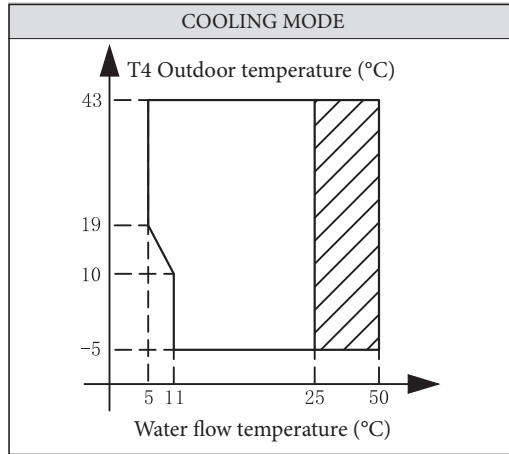

**Unit operating ranges 4-16 kW.**

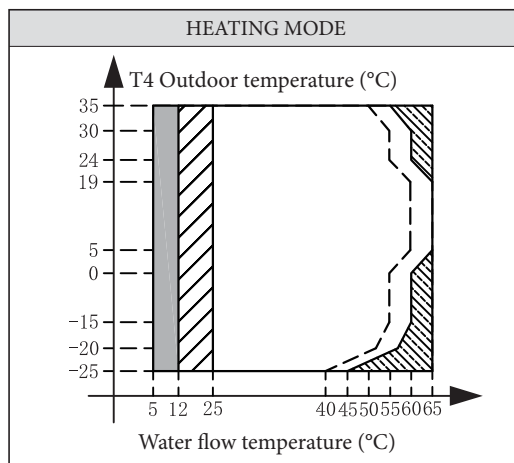

 Operating range by means of heat pumps with possible restriction and protection.





 If the IBH setting is active, only IBH switches on;  
If the IBH setting is not active, only the heat pump switches on; there could be cases of restriction and protection while the heat pump is running.

 Operating range by means of heat pumps with possible restriction and protection.

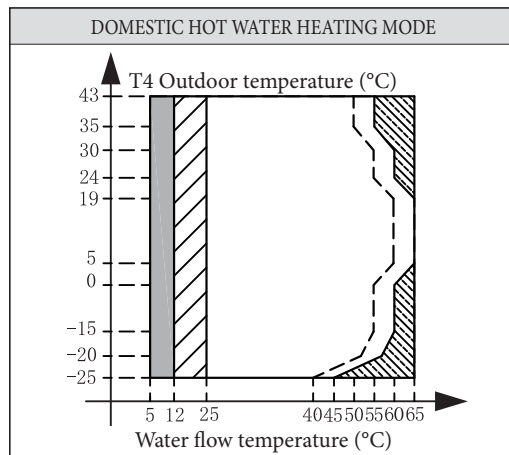
 The heat pump switches off, only IBH switches on.



 If the IBH setting is active, only IBH switches on;  
If the IBH setting is not active, only the heat pump switches on; there could be cases of restriction and protection while the heat pump is running.

 Operating range by means of heat pumps with possible restriction and protection.

 The heat pump switches off, only IBH switches on.



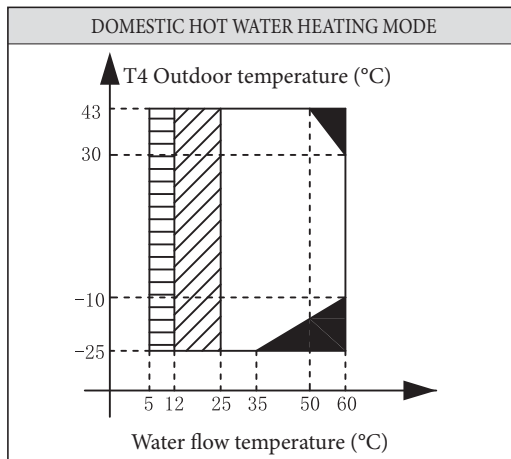
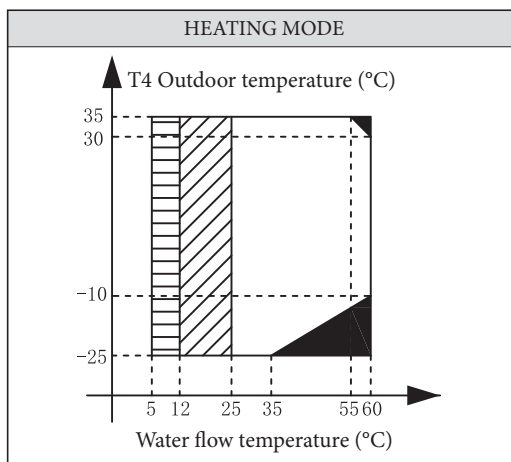
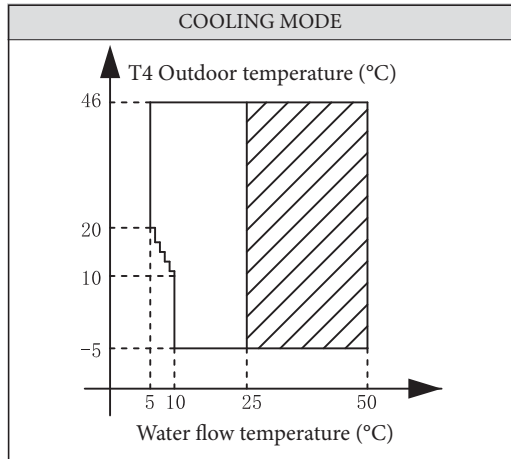















**Unit operating ranges 18-30 kW.**



- If the IBH setting is active, only IBH switches on;  
If the IBH setting is not active, only the heat pump switches on;
- No operation with heat pump, only IBH
- Water flow temperature descent or ascent interval



















# 3 ACCESSORIES.

## 3.1 ACCESSORIES SUPPLIED WITH THE UNITS 4-16 KW.

Accessories supplied with the units					
Name	Shape	Quantity	Name	Shape	Quantity
Use and maintenance manual		1	Temperature probe for domestic hot water (T5) or zone 2 (Tw2) or thermostat controlled storage tank (Tbt1)		1
Control Panel manual		1	Drain pipe		1
Technical data manual		1	Energy label		1
Y-shaped filter		1	Tighten the clip to use the client's wiring		2
					3
Control check		1	Network adapter		1
SG (SMART GRID) jumper		1	50 kΩ resistance for remote DHW demand		1
Accessories available from the supplier					
Probe for expansion tank (Tbt1)		1	Extension cable for Tw2		1
Extension cable for Tbt1		1	Solar temperature probe (Tsolar)		1
Zone 2 flow temperature probe (Tw2)		1	Extension cable for Tsolar		1

Probes and 10 m long extensions for Tbt1, Tw2, Tsolar can be shared; if these functions are necessary simultaneously, also order these probes and the extension cable.

### 3.2 ACCESSORIES SUPPLIED WITH THE UNITS 18-30 KW.

Accessories supplied with the units					
Name	Shape	Quantity	Name	Shape	Quantity
Use and maintenance manual		1	Y-shaped filter		1
Control Panel manual		1	Water outlet connection pipe group		2+2
Technical data manual		1	Control panel		1
Probe for domestic hot water tank (T5)*		1	Water inlet pipe adapter		1+1
Extension cable for T5		1	Network adapter**		1
Tighten the clip to use the client's wiring		2			
SG (SMART GRID) jumper		1	50 kΩ resistance for remote DHW demand		1
Accessories available from the supplier					
Probe for expansion tank (Tbt1)*		1	Extension cable for Tbt1		1
Zone 2 flow temperature probe (Tw2)		1	Extension cable for Tw2		1
Solar temperature probe (Tsolar)		1	Extension cable for Tsolar		1

\* = If the system is installed in parallel, Tbt1 must be connected and installed in the expansion tank.

\*\* = When the units are connected in parallel, for example when communication between the units is unstable (like a Hd failure code), add a corresponding network cable between ports H1 and H2 to the terminal of the communication system. The sensors Tbt1, T5 and the extension cable can be shared; the sensors Tw2, Tsolar and the extension wire can be shared. If these functions are needed at the same time, customise these sensors plus the extension.

# 4 PRIOR TO INSTALLATION.

- **Prior to installation.**

Make sure to confirm the model name and serial number of the unit.

- **Handling.**

Due to the relatively large size and heavy weight of the unit, it must only be handled with lifting equipment with harnessing. The harnesses can be fitted in the sleeves on the base frame, specifically made for this purpose.

## ⚠ CAUTION

- To avoid injuries, do not touch the air inlet or the aluminium fins of the unit.
- Do not use the grips of the fan grilles so as not to damage them.
- The unit is very heavy! Do not allow it to fall due to an incorrect inclination during handling.

### Models 4-16 kW

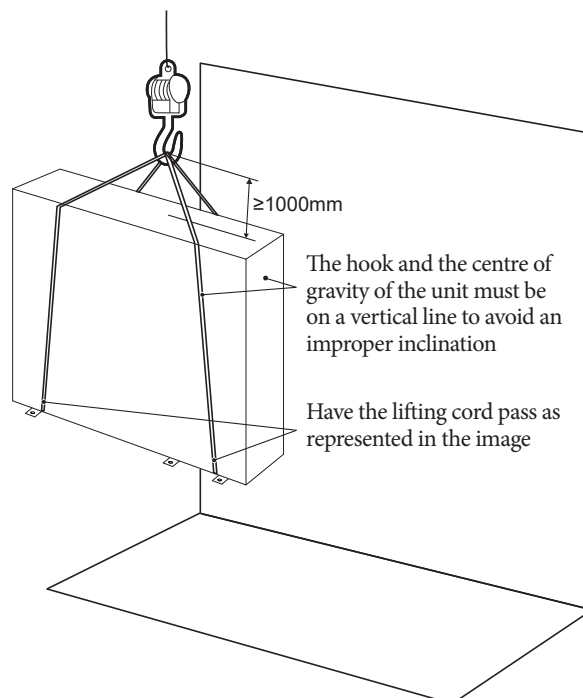

Position of the centre of gravity of the units 4-6 kW and 8-16 kW.

#### Models 4-6 kW

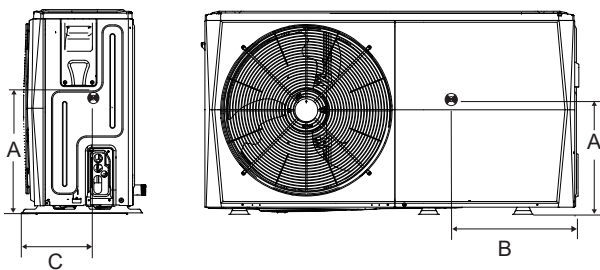

#### Models 8-16 kW

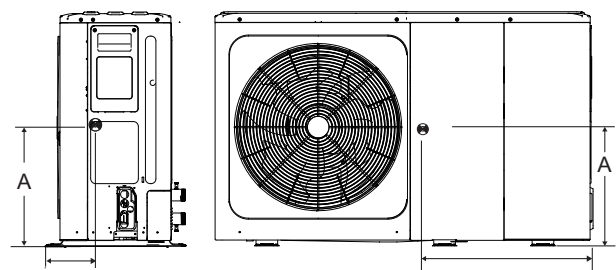

Model	A	B	C
Single phase 4-6 kW	296 mm	540 mm	190 mm
Single phase 8 kW	330 mm	580 mm	280 mm
Single phase 12-14-16 kW	290 mm	605 mm	245 mm
Three-phase 12-14-16 kW	200 mm	605 mm	245 mm

**Models 18-30 kW**

The hook and the centre of gravity of the unit must be on a vertical line to avoid an improper inclination

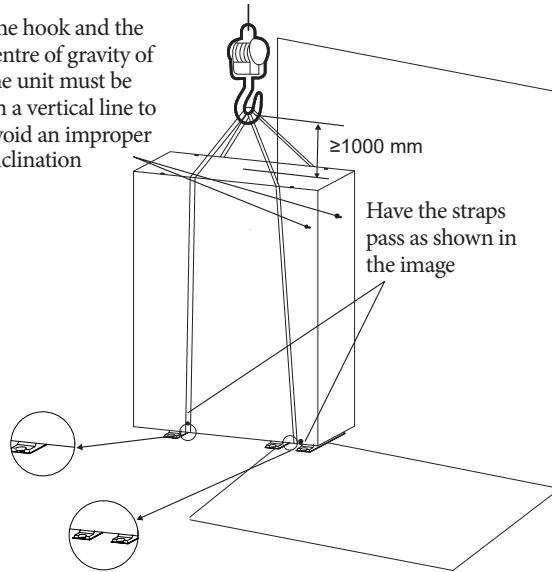

**Position of the centre of gravity of the units 18-30 kW.**

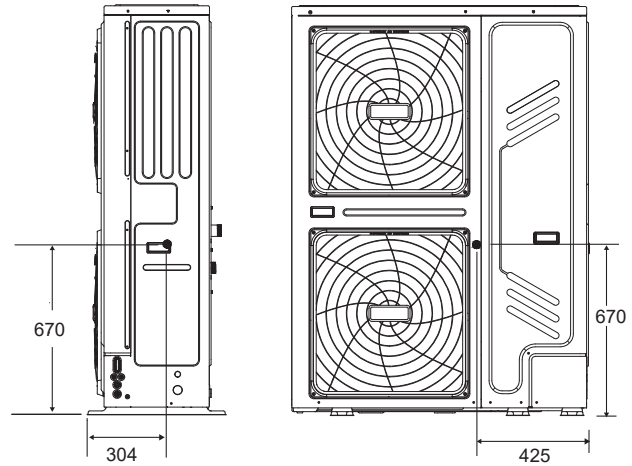

# 5 IMPORTANT INFORMATION ON THE REFRIGERANT.

This product contains fluorinated gas whose release into the air is prohibited.

Type of refrigerant: R32; Volume of GWP: 675.

GWP = Global Warning Potential

Model	Volume of refrigerant loaded in the unit at the factory	
	Refrigerant (kg)	Tonnes of CO <sub>2</sub> equivalent
4 kW	1.40	0.95
6 kW	1.40	0.95
8 kW	1.40	0.95
12 kW	1.75	1.18
14 kW	1.75	1.18
16 kW	1.75	1.18
18 kW	5.00	3.38
22 kW	5.00	3.38
26 kW	5.00	3.38
30 kW	5.00	3.38

**⚠ CAUTION**

- This unit is a hermetically sealed appliance that contains fluorinated greenhouse gas.
- Installation, operation and maintenance can only be carried out by certified persons.

## 6 INSTALLATION SITE.

### ⚠ WARNING

- The unit is supplied with flammable refrigerant and must be installed in a properly ventilated place. If the appliance is installed indoors, an additional refrigerant detection device must be added in addition to a further ventilation appliance pursuant to standard EN378. Make sure to take adequate measures so that the unit is not used to house small animals.
  - Animals that come into contact with electric components could cause operating failures, smoke or fire. Please advise the customer to keep the area around the unit clean.
- Choose an installation site where the following conditions are met and which is approved by the customer.
    - Well ventilated places.
    - Places where the unit does not bother neighbours.
    - Safe places that can bear the weight and vibrations of the unit and where it can be installed on a flat surface.
    - Places where flammable gas or flammable product leaks are not possible.
    - The appliance is not intended to be used in potentially explosive atmospheres.
    - Places where clearance for maintenance can be guaranteed.
    - Places where the pipes and lengths of the wiring of the units are within the admissible limits.
    - Places where the water escaping the appliance cannot damage the environment (e.g. in case of blocked drain pipe).
    - Places where rain can be prevented as far as possible.
    - Do not install the unit in places which are often used as workspace. In case of construction work (for example grinding, etc.) which creates lots of dust, the appliance must be covered.
    - Do not place any object or equipment above the unit (top plate).
    - Do not climb, sit or stand on the unit.
    - Make sure that sufficient precautions are taken in case of refrigerant leaks according to local laws and regulations on the matter.
    - Do not install the unit near the sea or in the presence of corrosive gas.
  - When the unit is installed in a place exposed to strong wind, pay particular attention to the following.
 

Strong winds 5 m/sec or more that blow against the air outlet of the unit cause a short circuit (suction of exhaust air) which could have the following consequences.

    - Deterioration of operating capacity.
    - Frequent acceleration of icing in heating mode.
    - Interruption of operation due to the high pressure increase.
    - When a strong wind continuously blows on the front of the unit, the fan can begin to spin so quickly that it breaks.

Under normal conditions, refer to the following figures for installation of the units 4-16 kW:

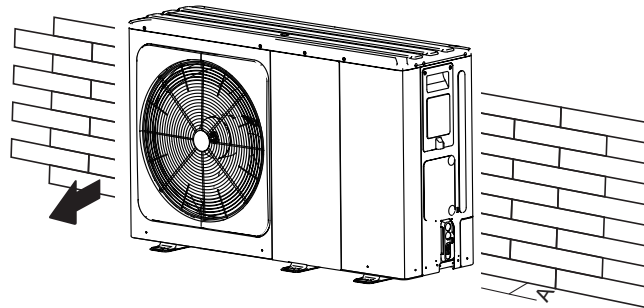

Unit	A
4-6 kW	≥ 300 mm
8-16 kW	≥ 300 mm



If there is strong wind and its direction can be foreseen, refer to the figures below for installation of the unit (any of them will do).

Turn the outlet side of the air towards the wall of the building, fence or screen.

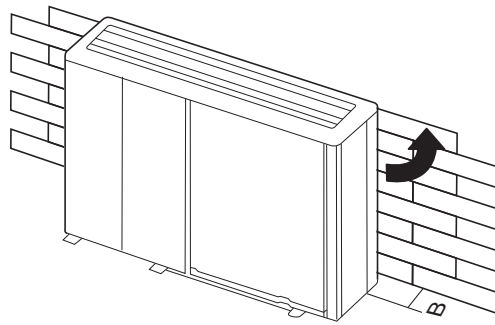

Unit	B
4-6 kW	≥ 1000 mm
8-16 kW	≥ 1500 mm

Make sure there is sufficient space for installation.

Arrange the outlet side at a right angle with respect to the wind direction.

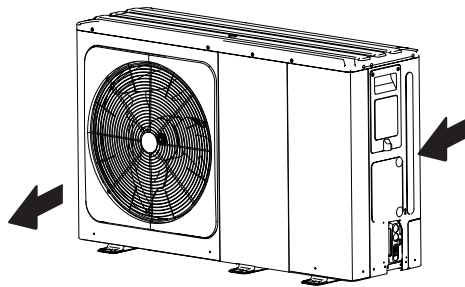

- Prepare a water discharge channel around the foundation, to drain the water around the unit.
- If the water has difficulty flowing out of the unit, mount the unit on a cement block foundation, etc. (approximately 100 mm (3.93 in) high).
- If the unit is installed on a frame, assemble a waterproof plate (about 100 mm) on the lower side of the unit to prevent the water from entering from below.
- When the unit is installed in a place frequently exposed to snow, please pay particular attention to raise the foundation as high as possible.

Under normal conditions, refer to the following figures for installation of the units 18-30 kW:

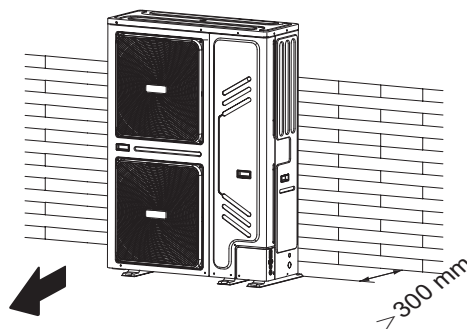

If there is strong wind and its direction can be foreseen, refer to the figures below for installation of the unit (any of them will do).

Turn the outlet side of the air towards the wall of the building, fence or screen.

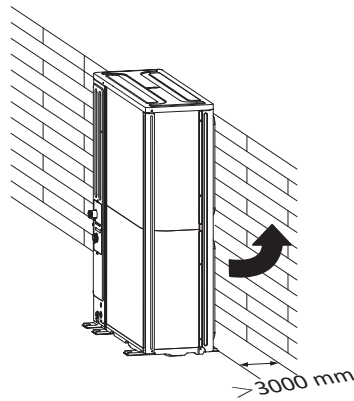

Make sure there is sufficient space for installation.

Arrange the outlet side at a right angle with respect to the wind direction.

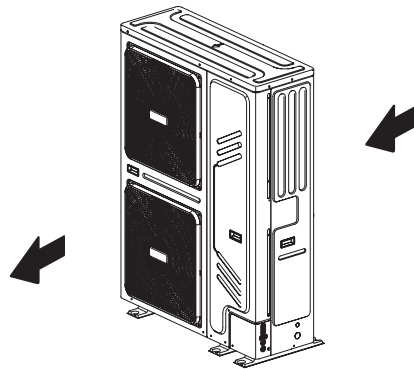

- Prepare a water discharge channel around the foundation, to drain the water around the unit.
- If the water has difficulty flowing out of the unit, mount the unit on a cement block foundation, etc. (approximately 100 mm (3.93 in) high).
- If the unit is installed on a frame, assemble a waterproof plate (about 100 mm) on the lower side of the unit to prevent the water from entering from below.
- When the unit is installed in a place frequently exposed to snow, please pay particular attention to raise the foundation as high as possible.
- If the unit is installed on a building structure, please install a waterproof tray (about 100 mm on the bottom side of the unit) so that the drain water does not flow out (See image below).



## 6.1 SELECTION OF A COLD WEATHER LOCATION.

See Chap. "Handling" in section "4 Prior to installation".

### NOTE

When the unit is used in cold climates, make sure to follow the instructions below.

- To avoid exposure to wind, install the unit with the intake side facing the wall.
- Never install the unit in a place where the intake side can be directly exposed to the wind.
- To avoid exposure to the wind, install a deflector on the air exhaust side of the unit.
- In areas with abundant snowfalls, it is very important to choose an installation site where the snow does not affect the appliance. If a side blowing snowfall can occur, make sure that the coil of the heat exchanger is not affected by the snow (build a roof when necessary).

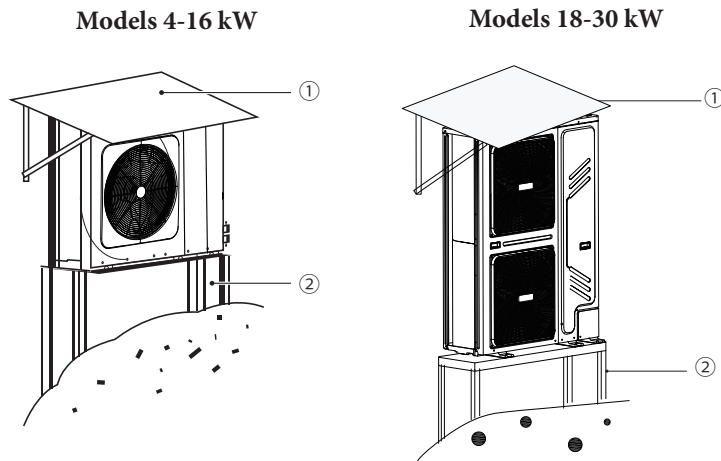

- 1) Build a large roof.
- 2) Build a pedestal.

Install the unit high enough so that it cannot be buried in the snow.

## 6.2 SELECTION OF A HOT WEATHER LOCATION.

Since the outside temperature is measured by the air thermistor of the heat pump, make sure to install the unit in the shade or to build a roof so that it is not exposed to direct sunlight and is not affected by the heat of the sun. Otherwise the unit will need to be protected.

# 7 INSTALLATION PRECAUTIONS.

## 7.1 DIMENSIONS.

**Models 4-6 kW**

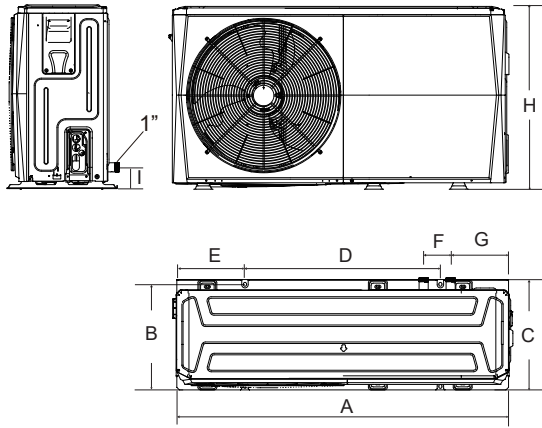

**Models 8-16 kW**

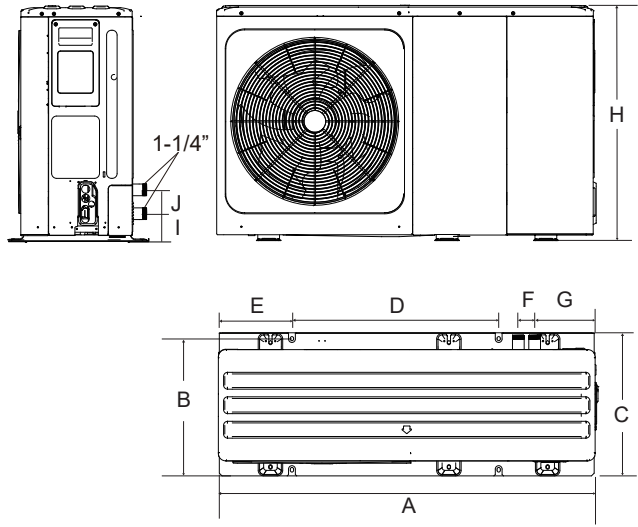

Model	A	B	C	D	E	F	G	H	I	J
4-6 kW	1295 mm	397 mm	429 mm	760 mm	265 mm	105 mm	225 mm	712 mm	81 mm	/
8-16 kW	1385 mm	482 mm	526 mm	760 mm	270 mm	60 mm	221 mm	865 mm	102 mm	81 mm

**Models 18-30 kW**

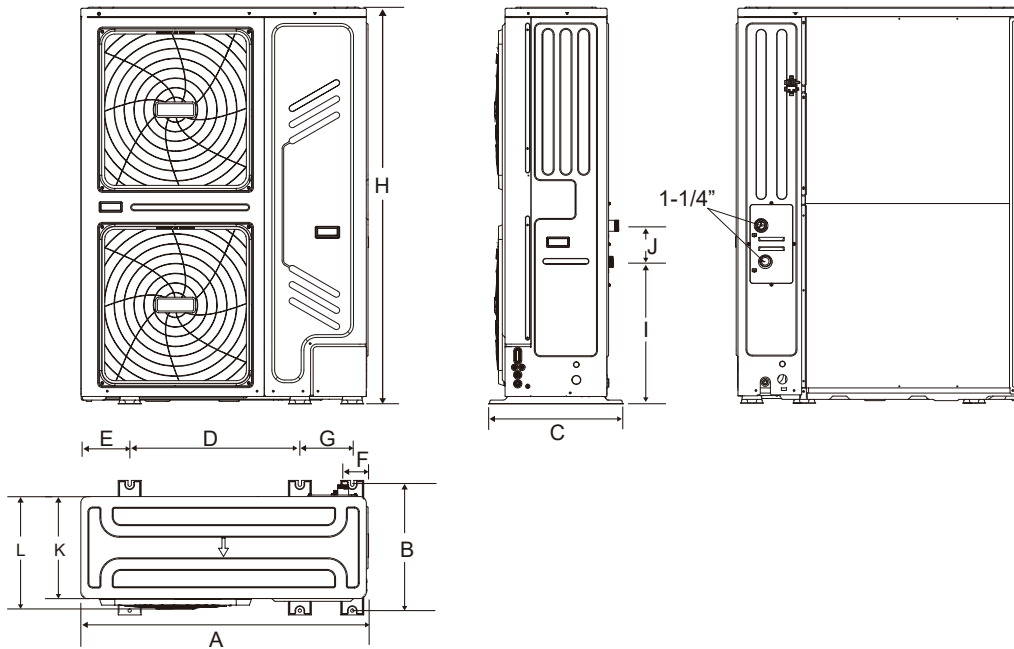

Model	A	B	C	D	E	F	G	H	I	J	K	L
18-30 kW	1129 mm	494 mm	528 mm	668 mm	192 mm	98 mm	206 mm	1558 mm	558 mm	143 mm	400 mm	440 mm

## 7.2 INSTALLATION REQUIREMENTS.

- Check the strength and level of the ground where the unit is installed so that it does not vibrate or make noise during operation.
- Secure the appliance firmly with anchor bolts according to the foundation drawing in the figure. (Prepare four series of  $\Phi 10$  expansion bolts, nuts and washers easily found on the market).
- Screw the anchor bolts up to 20 mm from the surface of the foundation.

### Models 4-16 kW

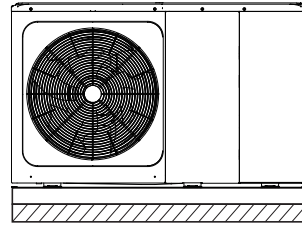
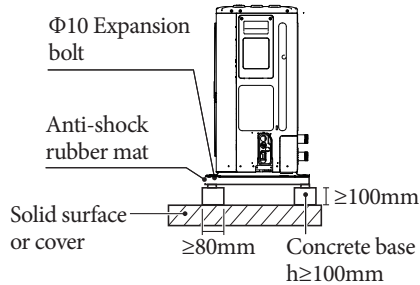

### Models 18-30 kW

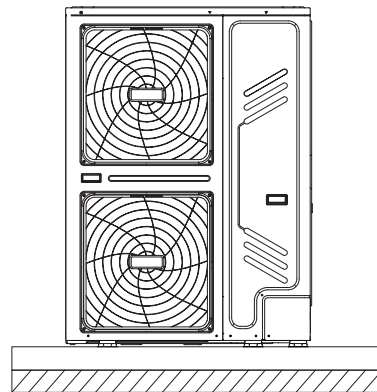
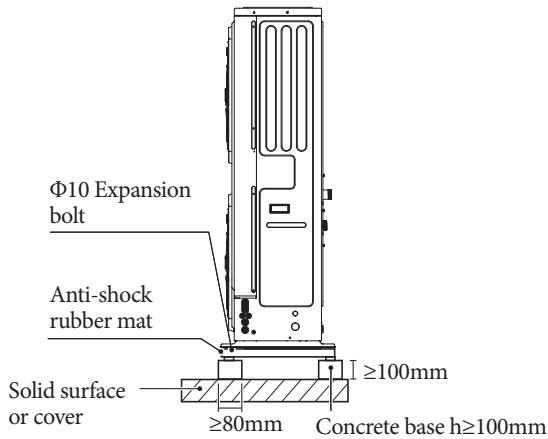

## 7.3 POSITION OF DRAIN HOLE.

### Models 4-6 kW

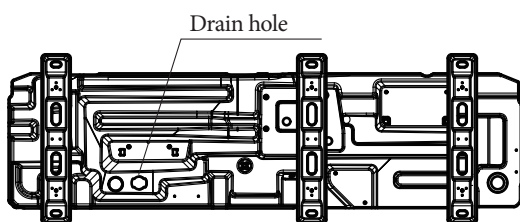

### Models 8-16 kW

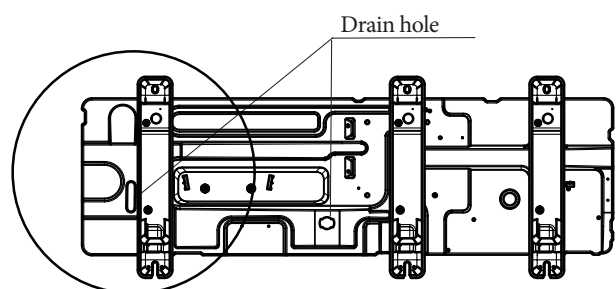

### Models 18-30 kW

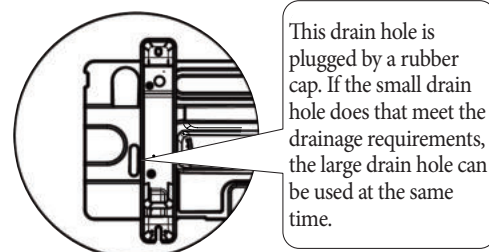
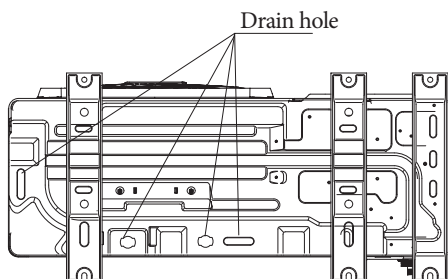

### NOTE

An electric heating cable must be installed if the water is not able to flow out due to the cold (Only for models 4-16 kW: even if the large drain hole is unplugged).

## 7.4 CLEARANCE REQUIREMENTS FOR MAINTENANCE.

### 7.4.1 Models 4-16 kW.

#### • In case of stacked installation.

1) If there are obstacles obstructing the outlet side.

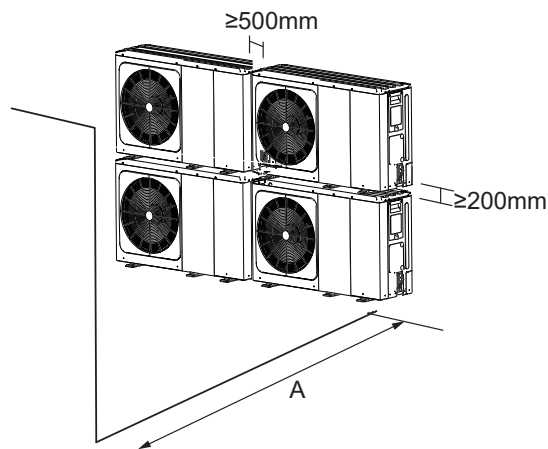

Unit	A
4-6 kW	≥ 1000 mm
8-16 kW	≥ 1500 mm

2) If there are obstacles obstructing the air inlet.

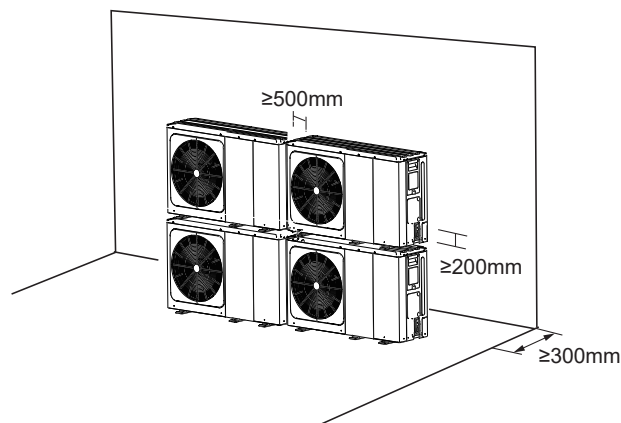

#### • For assembly in several rows (on roofs, etc.)

In case of installation of several units in rows side-by-side.

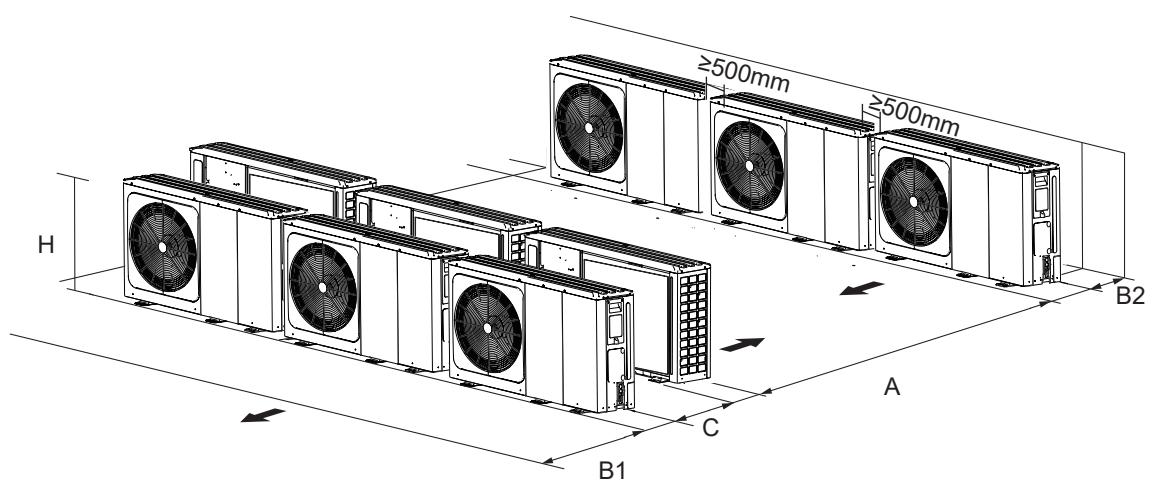

Unit	A	B1	B2	C
4-6 kW	≥ 2500 mm	≥ 1000 mm	≥ 300 mm	≥ 600 mm
8-16 kW	≥ 3000 mm	≥ 1500 mm		

### 7.4.2 Models 18-30 kW.

#### 1) Installation of a single unit.

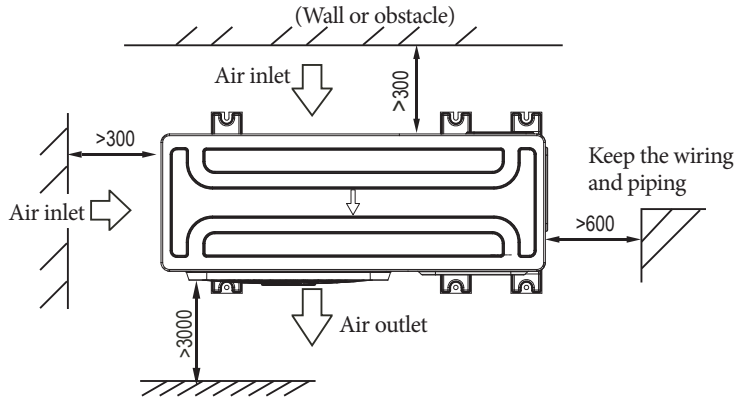

#### 2) Connect the two units in parallel or higher

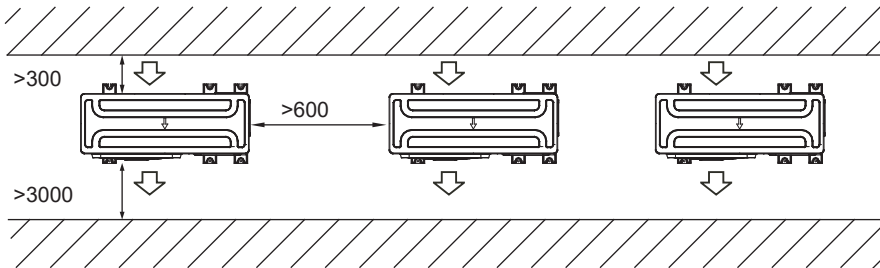

#### 3) Connect the front side parallel with the rear side

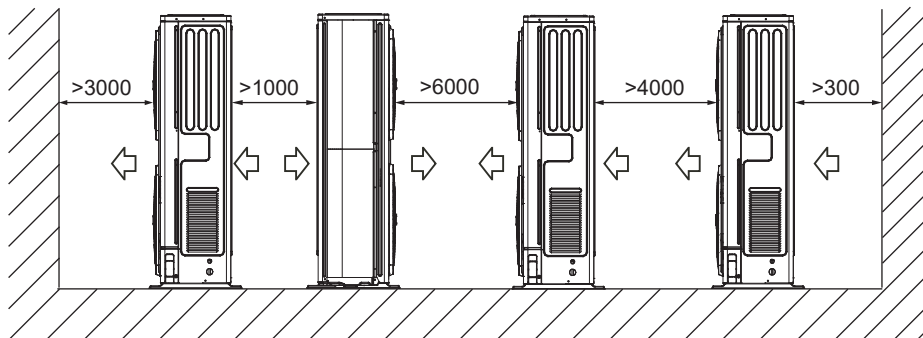



## 7.5 CONTROL PANEL INSTALLATION MANUAL.

### 7.5.1 Safety precautions.

- Read the safety precautions carefully before installing the unit.
- It is recommended to strictly abide by the important safety tips given below.
- Make sure that nothing anomalous occurs during execution of the test and completion of installation, then deliver the manual to the user.
- Meaning of symbols:

#### **WARNING**

Indicates that improper use could cause death or serious injury.

#### **CAUTION**

Indicates that improper use could cause irreparable damage to the appliance or personal injury.

#### **WARNING**

Have the unit installed by qualified technicians. Unqualified personnel might perform a non-professional installation, with the risk of electric shocks or fire.

Strictly follow the instructions in this manual. Incorrect installation could cause electric shocks or fire.

Re-installation must be carried out by qualified technicians. Incorrect installation could cause electric shocks or fire.

Do not take it upon yourself to disassemble the unit.

Incorrect disassembly could cause malfunctioning or overheating with the resulting risk of fire.

#### **CAUTION**

Do not install the unit in a place where flammable gas leaks could occur. A flammable gas leak near the control panel could burst into a fire.

Wiring must be adequate to the current intensity of the control panel. Otherwise an electric dispersion could occur with consequent risk of fire.

Use the cables indicated in the wiring diagram. Do not apply any external force to the terminal. Otherwise the wires could break, heat up and cause a fire.

### 7.5.2 Other precautions.

#### • Place of installation.

Do not install the unit in places where there are large amounts of oil, vapour, sulphurous gases. Otherwise the appliance could deform and become unusable.

#### • Preparation prior to installation.

1) Check that the following components are all present:

No.	Name	Qty	Notes
1	Control panel	1	-
2	Self-tapping round Philips head screw	3	For wall-mounting
3	Round Philips head screw	2	For mounting on electric switchgear
4	Use and installation manual	1	-
5	Plastic spacer	2	This accessory is used to install the control panel inside the electric cabinet
6	Plastic plug	3	For wall-mounting

• **Notes for installation of the control panel.**

- 1) This installation manual contains information on how to install the control panel.
- 2) The control panel is a low-voltage circuit. Never connect it to a normal 220V/380V circuit, or insert it in the same conduit as the circuit wiring.
- 3) The screened cable must be stably earthed or problems could occur regarding transmission of the signal.
- 4) Do not try to extend the screened cable by cutting it. Use the connection clamp if necessary.
- 5) After having performed the connection, do not use a Megger Tester to check isolation of the signal cable.

**7.5.3 Control panel installation and setting procedure.**

• **Dimensions.**

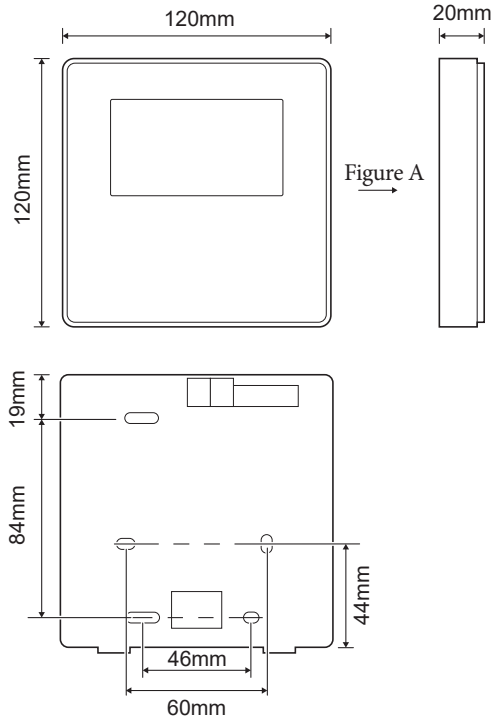

• **Wiring.**

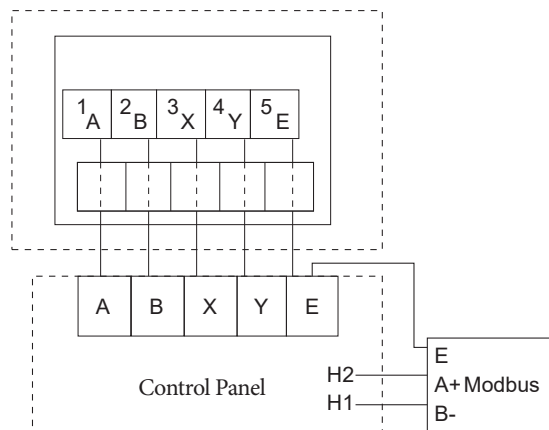

Input voltage (A/B)	13.5 V AC
Wiring dimensions	0.75 mm <sup>2</sup>

• **Installation of rear cover.**

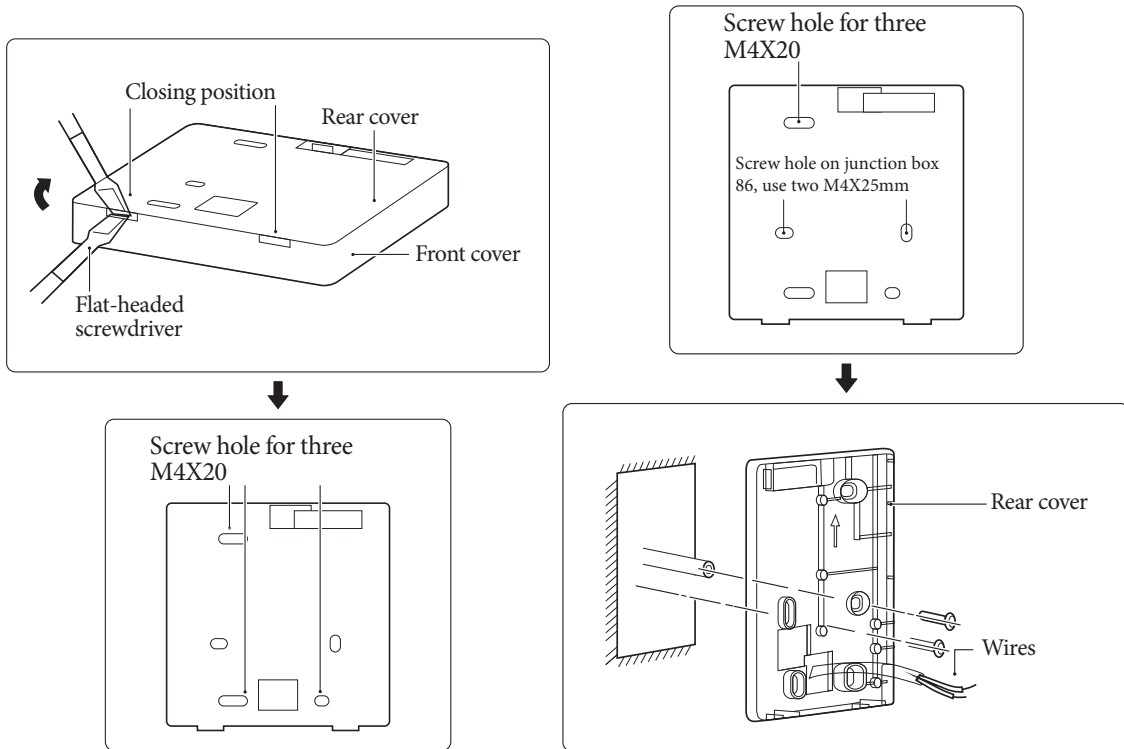

- 1) Insert a flat-headed screwdriver at the closing point at the bottom of the control panel and rotate the screwdriver to remove the rear cover (be careful not to damage it).
- 2) Use three M4X20 screws to directly mount the rear cover on the wall.
- 3) Use two M4X25 screws to install the rear cover on the junction box 86 and use a M4X20 screw to fix it to the wall.
- 4) When inserting the screw plug in the wall, make sure it is flush with the wall.
- 5) Use the Phillips screws to fix the bottom cover of the control panel into the wall using the screw plug. Make sure that the bottom cover of the control panel is at the same height after installation, then reposition the control panel on the bottom cover.
- 6) Do not overtighten the screw to prevent it from deforming the rear cover.

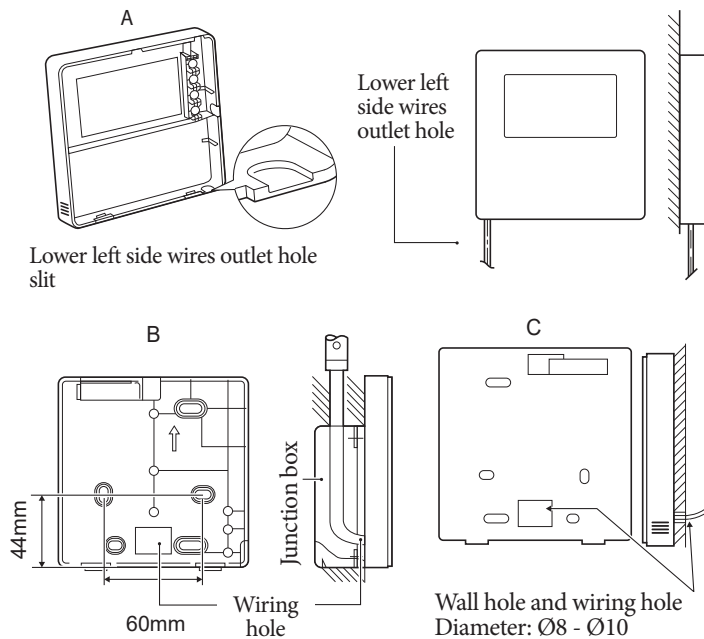

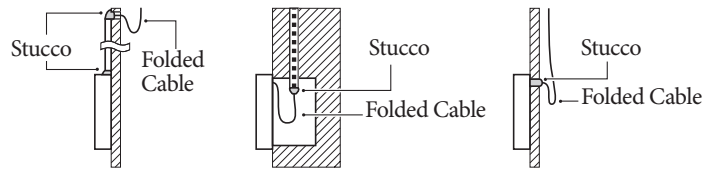

To prevent water from penetrating into the control panel, use anchoring and stucco to seal the passage holes when installing the wires.

#### 7.5.4 Installation of front cover.

After having positioned the front cover, close it without blocking the wire during installation.

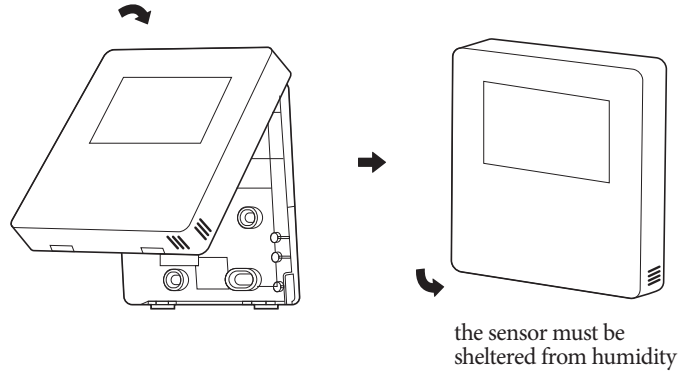

Install the rear cover correctly and firmly close the front and rear covers; otherwise the front cover will fall off.

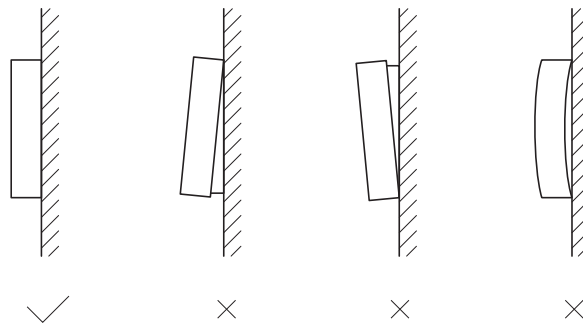

# 8 TYPICAL APPLICATION EXAMPLES.

The following application examples are for illustrative purposes only for units 4-16 kW.

## 8.1 UNITS 4-16 KW: APPLICATION 1.

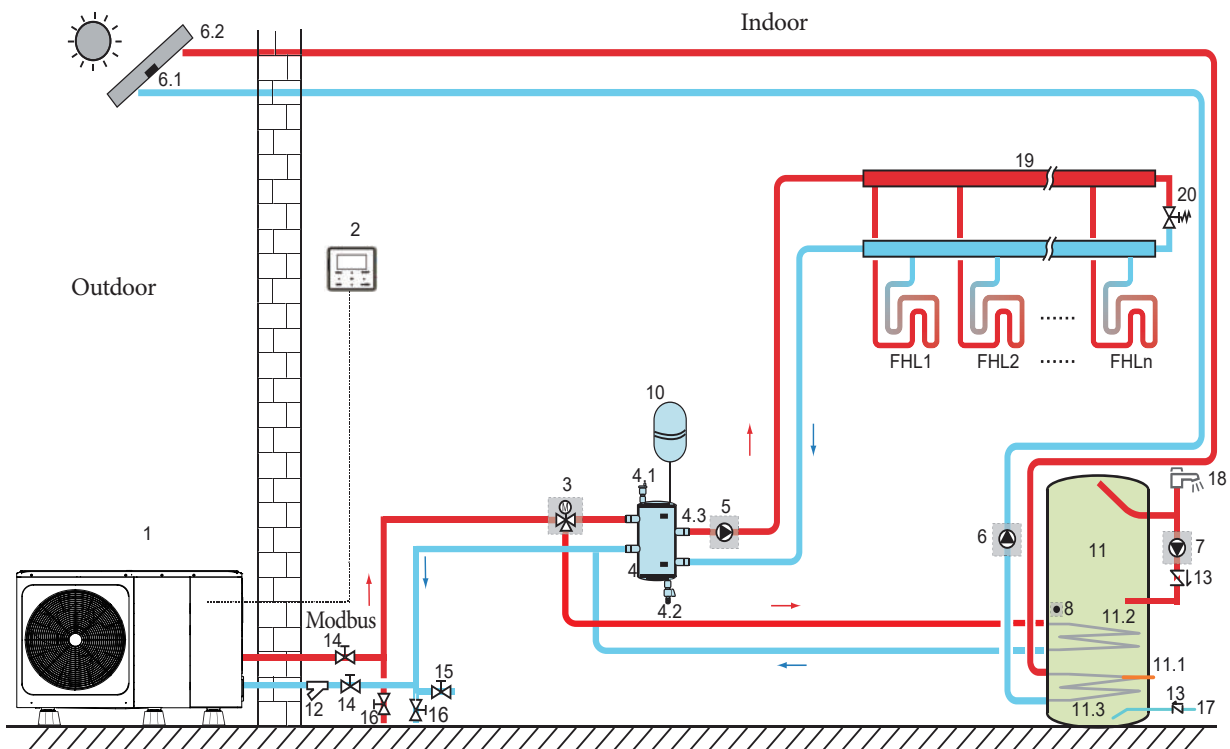

Code	Assembly unit	Code	Assembly unit
1	Main unit	11	Domestic hot water tank
2	Control panel	11.1	TBH: Heater of DHW storage tank
3	Sv1:3-way valve	11.2	Coil 1, heat exchanger for heat pump
4	Balance tank	11.3	Coil 2, heat exchanger for solar energy
4.1	Automatic air purge valve	12	Filter (accessory)
4.2	Discharge valve		
4.3	Tbt1: Upper temperature sensor of balance tank (optional)	14	Cut-off valve
5	P_o: External circulation pump	15	Filling valve
6	P_s: Solar pump	16	Discharge valve
6.1	Tsolar: Solar temperature sensor (optional)	17	Tap water inlet pipe
6.2	Solar panel	18	Hot water cock
7	P_d: Pump for DHW pipes	19	Manifold/distributor
8	T5: DHW temperature sensor (accessory)	20	Bypass valve
10	Expansion vessel	FHI 1... n	Floor heating circuit

- **Space heating.**

The ON/OFF signal and the operation mode, as well as the temperature settings, are set on the control panel. P\_o keeps running as long as the unit is at ON for space heating, SV1 remains OFF.

- **Domestic hot water heating.**

The ON/OFF signal and the target tank water temperature (T5S) are set on the control panel. P\_o stops as soon as the unit is at ON to heat the domestic hot water, SV1 remains ON.

- **TBH (tank booster heater) control.**

The TBH function is set on the control panel (Chap. 10.1 Overview of DIP switch settings)

1) When the TBH is set so as to be valid, TBH can be activated by means of the FAST DHW function on the control panel; in DHW mode, TBH will be activated automatically when the initial temperature T5 of the domestic hot water is too low or when the target temperature of the domestic hot water is too high at low room temperature.

2) When the TBH is set so as to be valid, M1M2 can be set so as to be valid on the control panel, TBH will be activated if the potential-free contact M1M2 closes.

- **Solar energy control.**

The hydraulic module recognises the solar energy signal by judging Tsolar or receiving the signal SL1SL2 from the control panel (Chap. 10.5.15 INPUT DEFINE). The recognition method can be set by means of the SOLAR INPUT on the control panel. See Chap. 9.7.6/1) “For active solar station contact” for wiring.

1) When Tsolar is set so as to be valid, solar energy is at ON when Tsolar is sufficiently high, P\_s starts to operate; solar energy is OFF when Tsolar is low, P\_s stops.

2) When the control SL1SL2 is set so as to be valid, solar energy activates (ON) after having received the control panel solar kit signal, P\_s starts to operate. Without the solar kit signal, solar energy deactivates (OFF), P\_s stops.

### CAUTION

The outlet water can reach a maximum temperature of 70°C, pay attention to burns.

### NOTE

Make sure to insert the 3-way valve (SV1) correctly. For further details, see section 9.7.6 “Connection for other components”.

With room temperatures extremely low, the domestic hot water is only heated by TBH, which guarantees that the heat pump can be used for space heating with the maximum capacity.

Details on configuration of the storage tank for domestic hot water for low outdoor temperatures (T4DHWMIN) are found in Chap. 10.5.1 “DHW MODE SETTING”.

### 8.1.1 With Indoor unit backup heater.

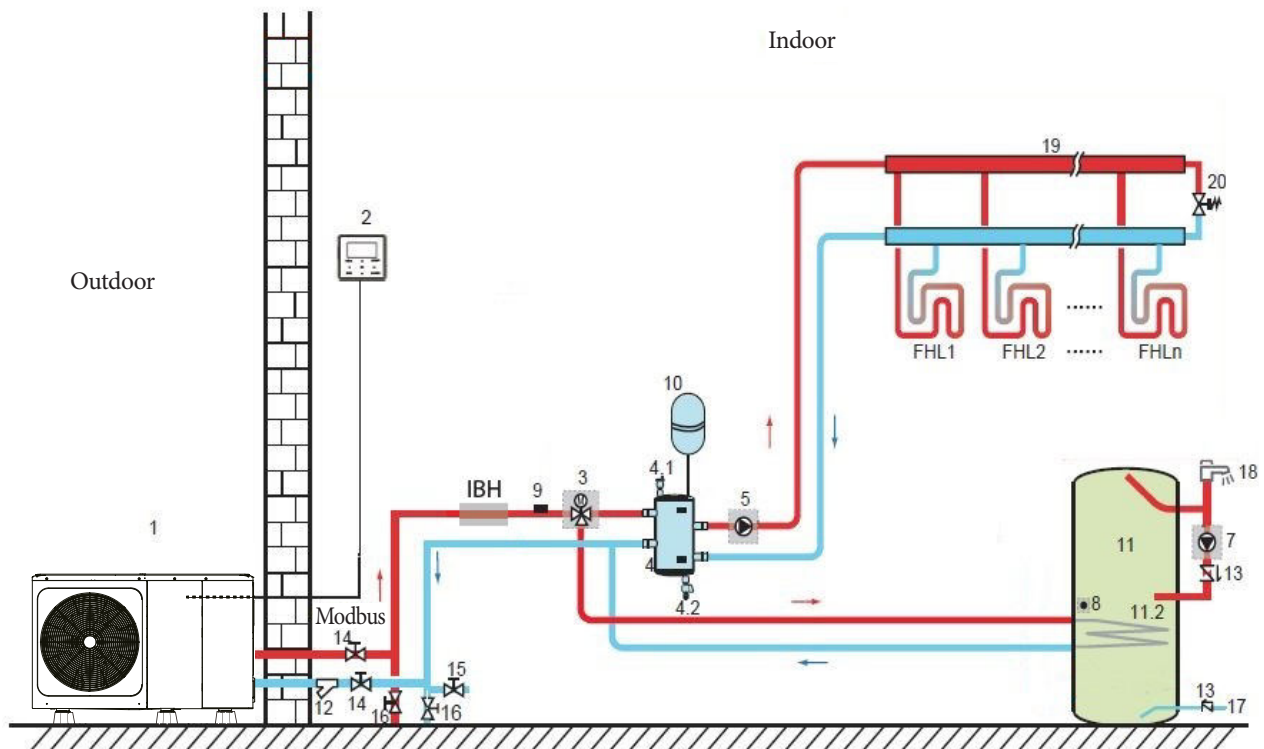

Code	Assembly unit	Code	Assembly unit
1	Main unit	11.2	Coil, heat exchanger for heat pump
2	Control panel	12	Filter (accessory)
3	Sv1: 3-way valve	13	Control valve
4	Balance tank	14	Cut-off valve
4.1	Automatic air purge valve	15	Filling valve
4.2	Discharge valve	16	Discharge valve
5	P_o: External circulation pump	17	Tap water inlet pipe
7	P_d: Pump for DHW pipes	18	Hot water cock
8	T5: DHW temperature sensor (accessory)	19	Manifold/distributor
9	T1: Total water flow temperature sensor (optional)	20	Bypass valve
10	Expansion vessel	FHL 1... n	Floor heating circuit
11	Domestic hot water tank	IBH	Indoor unit backup heater

#### IBH (Indoor unit backup heater) control.

The IBH function is set on the main hydronic board (Chap. 10.1 Overview of DIP switch settings).

1) When the IBH is set so as to be valid only for heating mode, the IBH can be activated as follows:

- a. Activate IBH by means of the BACKUP HEATER function on the control panel;
- b. The IBH will be activated automatically if the initial temperature of the water is too low or if the target water temperature is too high at a low room temperature.

P\_o keeps running as long as IBH is ON, SV1 remains OFF.

2) When IBH is set so as to be valid for heating mode and DHW mode.

In heating mode, the IBH control is equal to part 1).

In DHW mode, IBH will be activated automatically if the initial temperature of the domestic hot water T5 is too low or the target domestic hot water temperature is too high at a low room temperature.

P\_o stops, SV1 remains set at ON.



## 8.2 UNITS 4-16 KW: APPLICATION 2.

The ROOM THERMOSTAT control for space heating or cooling can be set on the control panel. It can be set in three modes: MODE SET/ONE ZONE/DOUBLE ZONE. The unit can be connected to a high-voltage room thermostat and to a low-voltage room thermostat. See Chap. 9.7.6/5) “FOR ROOM THERMOSTAT” for wiring (Chap. 10.5.6 “ROOM THERMOSTAT” for the setting).

### 8.2.1 One Zone Control

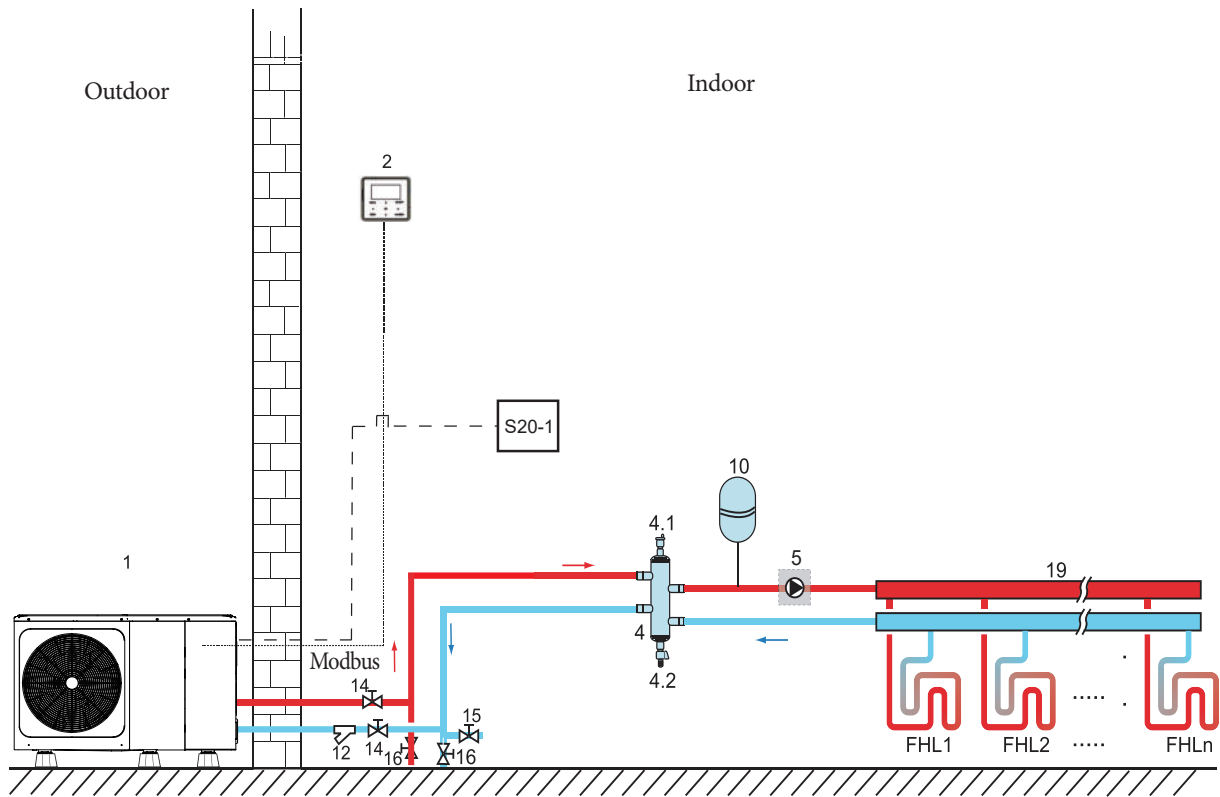

Code	Assembly unit	Code	Assembly unit
1	Main unit	12	Filter (accessory)
2	Control panel	14	Cut-off valve
4	Balance tank	15	Filling valve
4.1	Automatic air purge valve	16	Discharge valve
4.2	Discharge valve	19	Manifold/distributor
5	P_o: External circulation pump	S20-1	Room thermostat
10	Expansion vessel	FHL 1... n	Floor heating circuit

#### • Space heating.

One zone control: the ON/OFF signal is controlled by the room thermostat, heating or cooling modes and the outlet water temperature are set on the control panel. The system is ON when “H” on the thermostat closes (\*). When “H” on the thermostat opens, the system switches OFF.

#### • Circulation pumps operation.

When the system is at ON, which means “H” on the thermostat closed, P\_o starts running;

When the system is OFF, which means “H” on the thermostat open, P\_o stops.

(\*): By H closed we mean: closed contact between H and L1 for the high-voltage room thermostat or closed contact between HT and COM for the low-voltage thermostat.

## 8.2.2 Mode setting control.

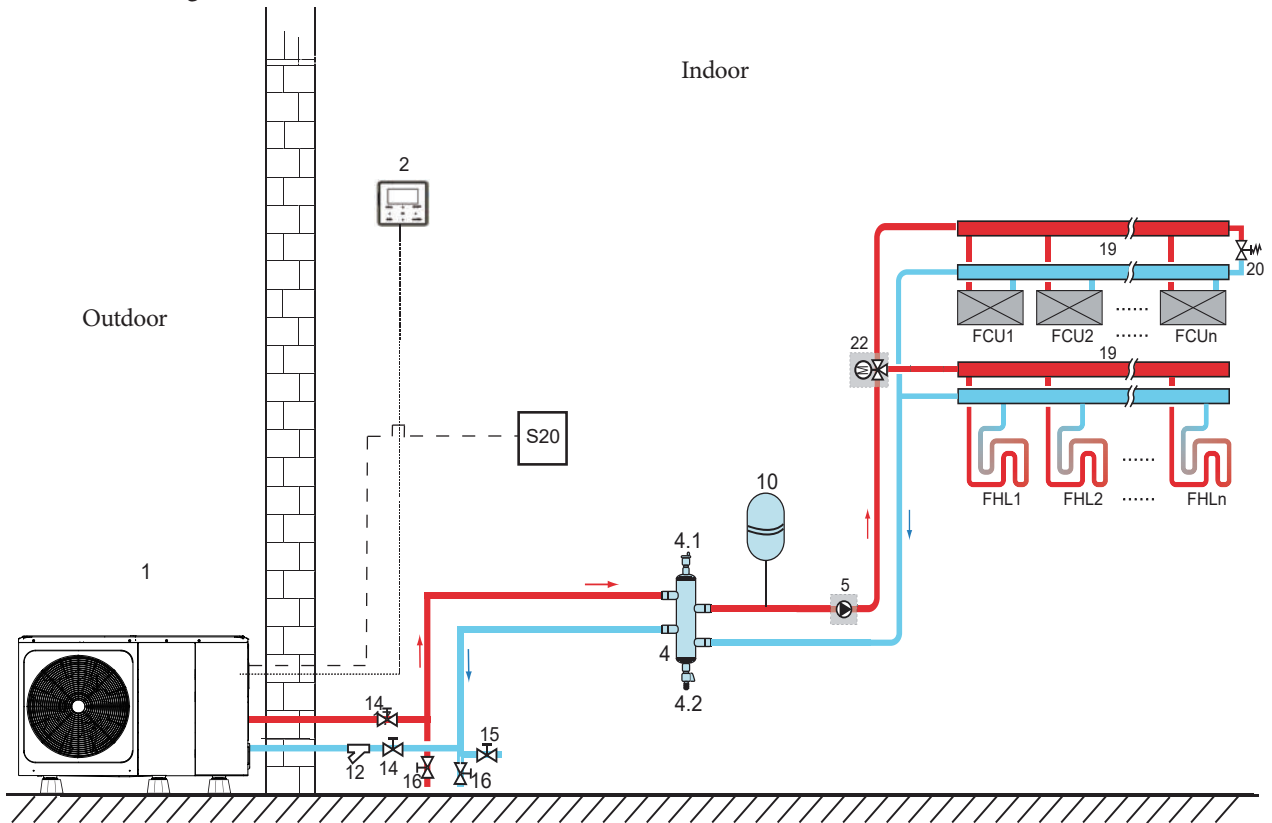

Code	Assembly unit	Code	Assembly unit
1	Main unit	14	Cut-off valve
2	User interface	16	Discharge valve
4	Balance tank	19	Manifold/distributor
4.1	Automatic air purge valve	20	Bypass valve
4.2	Discharge valve	22	SV2: 3-way valve
5	P_o: External circulation pump	S20	Room thermostat
10	Expansion vessel	FHL 1... n	Floor heating circuit
12	Filter (accessory)	FUC 1... n	Fan coil

### • Space Heating/Cooling.

The cooling or heating mode is set on the room thermostat, the water temperature is set on the user interface.

- 1) When “C” on the thermostat closes, the system will be set in cooling mode (\*).
- 2) When “H” on the thermostat closes and “C” opens, the system will be set in heating mode.

### • Circulation pumps operation.

- 1) When the system is in cooling mode, which means “C” on the thermostat closed, SV2 remains OFF, P\_o starts to run.
- 2) When the system is in heating mode, which means “H” on the thermostat closed and “C” opened, SV2 remains ON, P\_o starts to run.

(\*): By C closed we mean: closed contact between C and L1 for the high-voltage room thermostat or closed contact between CL and COM for the low-voltage thermostat

### 8.2.3 Double zone control.

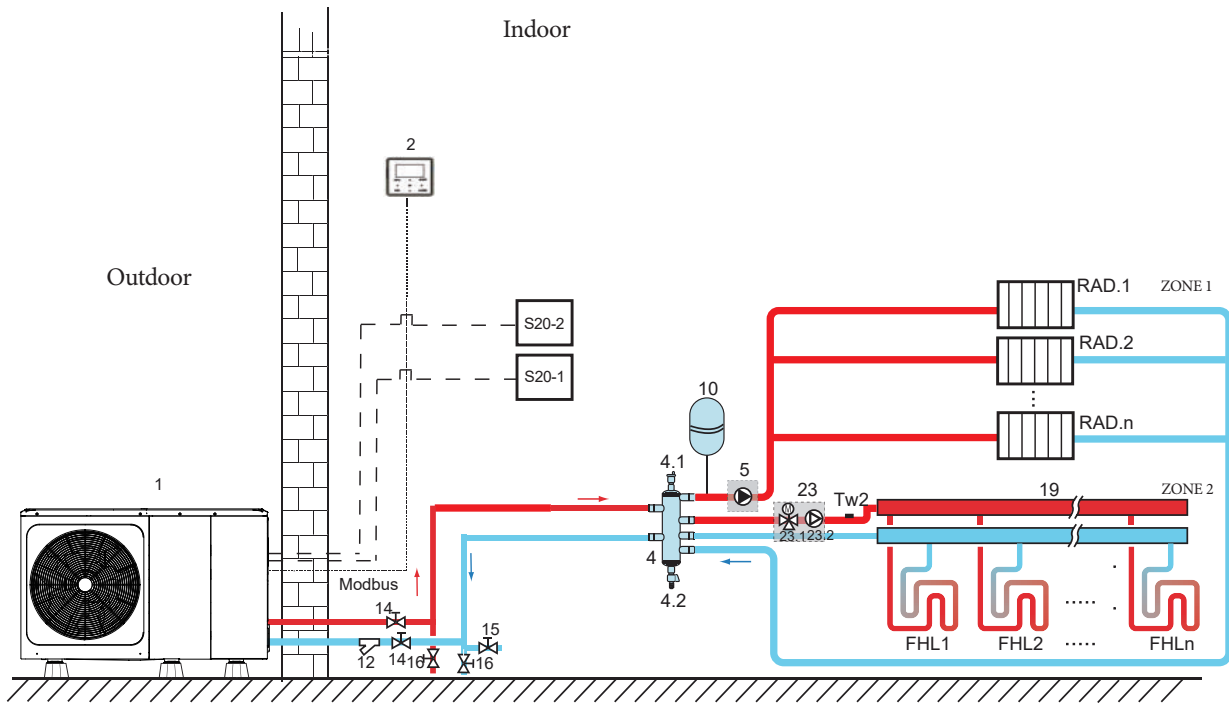

Code	Assembly unit	Code	Assembly unit
1	Main unit	16	Discharge valve
2	Control panel	19	Manifold/distributor
4	Balance tank	23	Mixing kit
4.1	Automatic air purge valve	23.1	SV3: Mixing valve
4.2	Discharge valve	23.2	P_c: Zone 2 circulation pump
5	P_o: Zone 1 circulation pump	S20-1	Zone 1 Room thermostat
10	Expansion vessel	S20-2	Zone 2 Room thermostat
12	Filter (accessory)	Tw2	Zone 2 water low temperature sensor (optional)
14	Cut-off valve	FHL 1... n	Floor heating circuit
15	Filling valve	RAD. 1... n	Radiator

#### • Space heating.

Zone 1 can operate in cooling mode or in heating mode, while Zone 2 can only operate in heating mode; upon installation, the thermostat in Zone 1 must be connected to “H”. The thermostat in Zone 2 must be connected to “C”.

1) Switching Zone 1 ON/OFF is controlled by the Zone 1 room thermostat. When “H” on the Zone 1 thermostat closes, Zone 1 switches ON. When “H” opens, Zone 1 switches OFF; the target temperature and the operation mode are set on the control panel.

2) In heating mode, switching Zone 2 ON/OFF is controlled by the Zone 2 room thermostat. When “C” on the Zone 2 thermostat closes, Zone 2 switches ON. When “C” opens, Zone 2 switches OFF. The target temperature is set on the control panel; Zone 2 can only operate in heating mode. When cooling mode is set on the control panel, the Zone remains OFF:

#### • Circulation pumps operation.

When Zone 1 is ON, P\_o starts to run; when Zone 1 is OFF, P\_o stops.

When Zone 2 is ON, SV3 alternates between ON and OFF according to the set Tw2, P\_c remains ON; when Zone 2 is OFF, SV3 is OFF, P\_c stops.

The floor heating circuits require a lower water temperature in heating mode than the radiators or fan coil unit. A mixing kit is used to reach these two set points to adapt the water temperature based on the requirements of the floor heating circuits. The radiators are connected directly to the water circuit of the unit and the floor heating circuits are located after the mixing kit. The mixing kit is controlled by the unit.

#### CAUTION

- 1) Make sure to connect terminals SV2/SV3 correctly in the control panel; see Chap. 9.7.6/2) for the 3-way valves SV1, SV2 and SV3.
- 2) Connect the thermostat cables to the relative terminals and configure the ROOM THERMOSTAT correctly in the control panel. Wiring of the room thermostat should follow the A/B/C method as described in Chap. 9.7.6 “Connection for other components/5) for the room thermostat.

#### NOTE

- 1) Zone 2 can only run in heating mode. When cooling mode is set on the control panel and Zone 1 is OFF, “CL” in Zone 2 closes, the system remains OFF. The wires of the thermostats for Zone 1 and Zone 2 must be installed correctly.
- 2) The drain valve must be installed at the lowest position of the pipe system.

### 8.3 UNITS 4-16 KW: CASCADE SYSTEM.

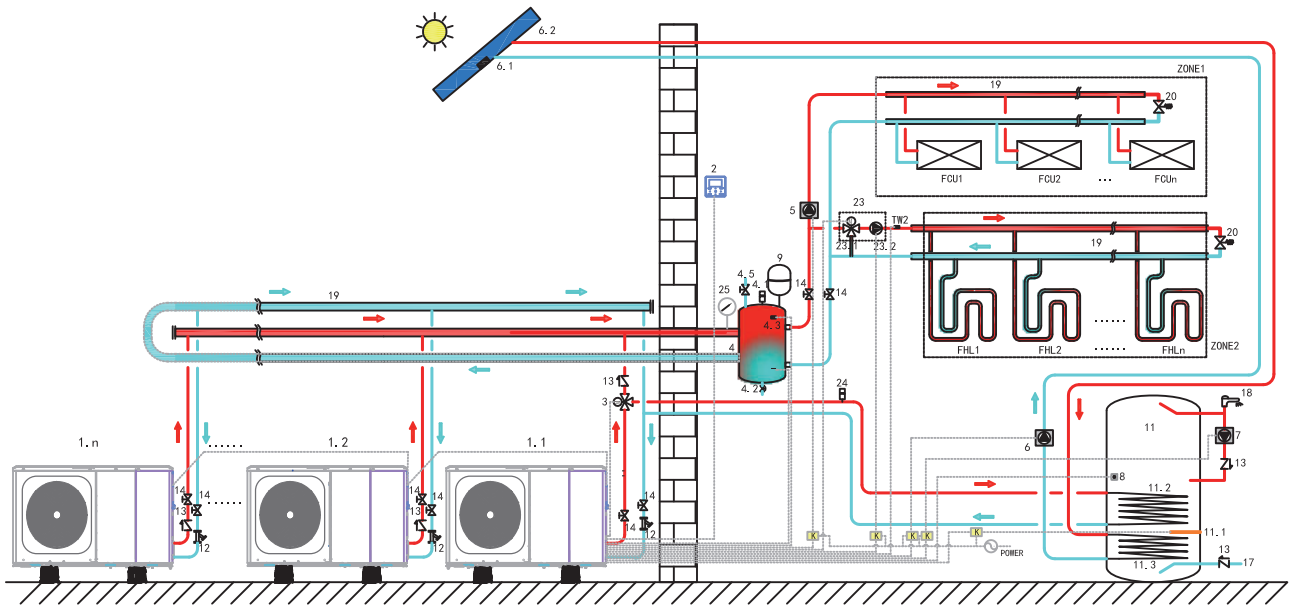

Code	Assembly unit	Code	Assembly unit	Code	Assembly unit
1.1	Master Unit	6.1	Tsolar: Solar temperature sensor (optional)	18	Hot water cock
1.2... n	Slave Unit	6.2	Solar panel	19	Manifold/distributor
2	Control panel	7	P_d: Pump for DHW pipes	20	Bypass valve
3	Sv1: 3-way valve	8	T5: DHW temperature sensor (accessory)	23	Mixing kit
4	Balance tank	9	Expansion vessel	23.1	SV3: Mixing valve
4.1	Automatic air purge valve	11	Domestic hot water tank	23.2	P_c: Zone 2 circulation pump
4.2	Discharge valve	11.1	TBH: Heater of DHW storage tank	24	Automatic air purge valve
4.3	Tbt1: Upper temperature sensor of balance tank (optional)	11.2	Coil 1, heat exchanger for heat pump	25	Water pressure gauge
4.4	Tbt2: Lower temperature sensor of balance tank (optional)	11.3	Coil 2, heat exchanger for solar energy	Tw2	Zone 2 water flow temperature sensor (optional)
4.5	Filling valve	12	Filter (accessory)	RAD1... n	Radiator
5	P_o: External circulation pump	14	Cut-off valve	FHL 1... n	Floor heating circuit
6	P_s: Solar pump	17	Tap water inlet pipe	ZONE1	The space works in cooling or heating mode
				ZONE2	The room only runs in cooling mode

#### • Domestic hot water heating.

Only the master unit (1.1) can function in DHW mode. T5S is set on the control panel (2). In DHW mode, SV1 (3) remains ON. When the master unit runs in DHW mode, the slave units can operate in space cooling/heating mode.

• **Space heating.**

All the slave units can work in space heating mode. The operation mode and temperature setpoint are set on the control panel (2). Due to the variations of the outdoor temperature and of the load required indoors, several outdoor units can operate at different times.

In cooling mode, SV3 (23.1) and P\_c (23.2) remain OFF. P\_o (5) remains ON.

In heating mode, when both ZONE1 and ZONE2 are working, P\_c (23.2) and P\_o (5) remain ON, SV3 (23.1) alternates between ON and OFF depending on the set Tw2.

In heating mode, when only ZONE1 works, P\_o (5) remains ON, SV3 (23.1) and P\_c (23.2) remain OFF.

In heating mode, when only ZONE2 works, P\_o (5) remains OFF, P\_c (23.2) remains ON, SV3 (23.1) alternates between ON e OFF according to the set Tw2.

• **TBH (tank booster heater) control.**

The TBH must be set using the dip switches on the main board (refer to Chap. 10.1). The TBH is only controlled by the master unit. Refer to 8.1 for the specific control of the TBH.

• **Solar energy control.**

Energy is only controlled by the master unit. Please refer to Chap. 8.1 for the specific control of solar energy.

**NOTE**

1. A maximum of 6 units can be connected in cascade in a system. One of them is the master unit, the others are slave units; the master unit and the slave units can be recognised by whether or not they are connected to the control panel during operation. The unit with control panel is the master unit, the units without control panel are slave units. Only the master units can operate in DHW mode. During installation, check the diagram of the cascade system and determine the master unit; before switching on, remove all the control panels of the slave units.
2. SV1, SV2, SV3, P\_o, P\_c, P\_s, T1, T5, Tw2, Tbt1, Tsolar, SL1SL2, TBH and the control panel must only be connected to the matching terminals on the main board of the master unit. See Chap. 9.3.1 and 9.7.6.
3. The system is equipped with the self-addressing function. After being switched on the first time, the masters unit assigns the addresses for the slave units. The slave units will maintain the addresses. After being switched back on, the slave units will still use the prior addresses. It is not necessary to set the addresses of the slave units again.
4. If an Hd error occurs, refer to Chap. 13.4.
5. It is recommended to use the inverted water return system to avoid hydraulic unbalance between each unit in a cascade system.

**CAUTION**

1. In a cascade system, the sensor Tbt1 must be connected to the master unit and Tbt1 set as valid on the control panel (see Chap. 10.5.15). Otherwise none of the slave units will work.
2. If the external circulation pump needs to be connected in series in the system when the head of the internal water pump is not sufficient, it is recommended to install the external circulation pump after the balance tank.
3. Please make sure that the maximum ignition time interval of all units does not exceed 2 minutes, otherwise the time for the request and assignment of the addresses will not be reached, which could make it impossible for the slave units to communicate normally, triggering an Hd error.
4. A maximum of 6 units can be connected in cascade in a system.
5. The outlet pipe of each unit must be installed with a non-return valve.

**Volume requirement of the expansion tank.**

Model	Balance tank (L)
4-8 kW	≥ 25
12-16 kW	≥ 40
cascade system	≥ 40*n
n = number of outdoor units	

The following application examples are for illustrative purposes only for units 18-30 kW.

### 8.4 UNITS 18-30 KW: APPLICATION 1.

Space heating with a room thermostat connected to the unit.

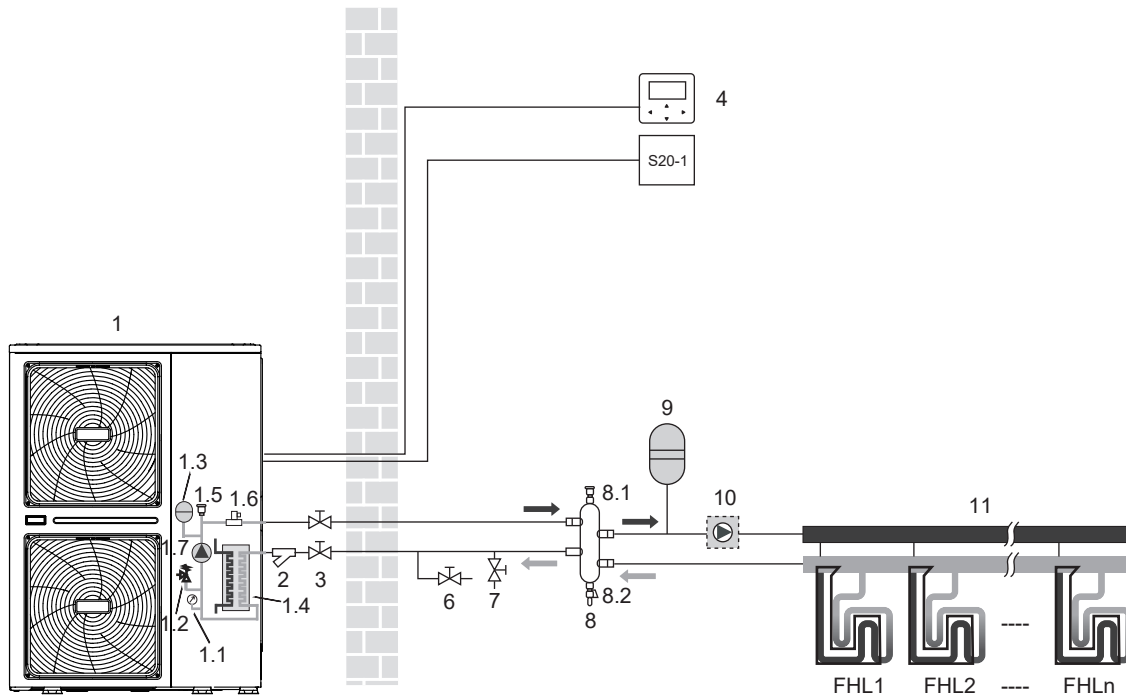

Code	Assembly unit	Code	Assembly unit
1	Heat pump	S20-1	Room thermostat
1.1	Pressure gauge	6	Discharge valve
1.2	Pressure relief valve	7	Filling valve
1.3	Expansion vessel	8	Balance tank
1.4	Plate heat exchanger	8.1	Air purge valve
1.5	Air purge valve	8.2	Discharge valve
1.6	Flow switch	9	Expansion vessel
1.7	P_i: Circulation pump inside the unit	10	P_o: External circulation pump
2	Y-shaped filter	11	Manifold/distributor
3	Shut-off valve	FHL 1... n	Floor heating circuit
4	Control panel		

#### NOTE

The volume of the balance tank (8) must be greater than 40 L. The drain valve (6) must be installed in the lowest position of the water system. The pump P<sub>o</sub> (10) must be controlled by the heat pump and connected to the corresponding port of the unit (Chap. 9.7.6 Connection for other components/For the external circulation pump P<sub>o</sub>).

Operation of the unit and space heating.

When a room thermostat is connected to the unit and there is a heating demand by the room thermostat, the unit will start to run to reach the nominal flow temperature of the water set on the control panel. When the room temperature is higher than the setpoint of the thermostat in heating mode, the unit switches off. The circulation pump (1.7) and (10) also stops. Here the room thermostat is used as a switch.

#### NOTE

Make sure to connect the wires of the thermostat to the correct terminals, selecting method B (see “For room thermostat” in Chap. 9.7.6 Connection for other components). See Chap. 10.5.6 “Room thermostat” for the setting).

### 8.5 UNITS 18-30 KW: APPLICATION 2.

Space heating without a room thermostat connected to the unit. The domestic hot water tank is connected to the unit and the tank has the solar heating system.

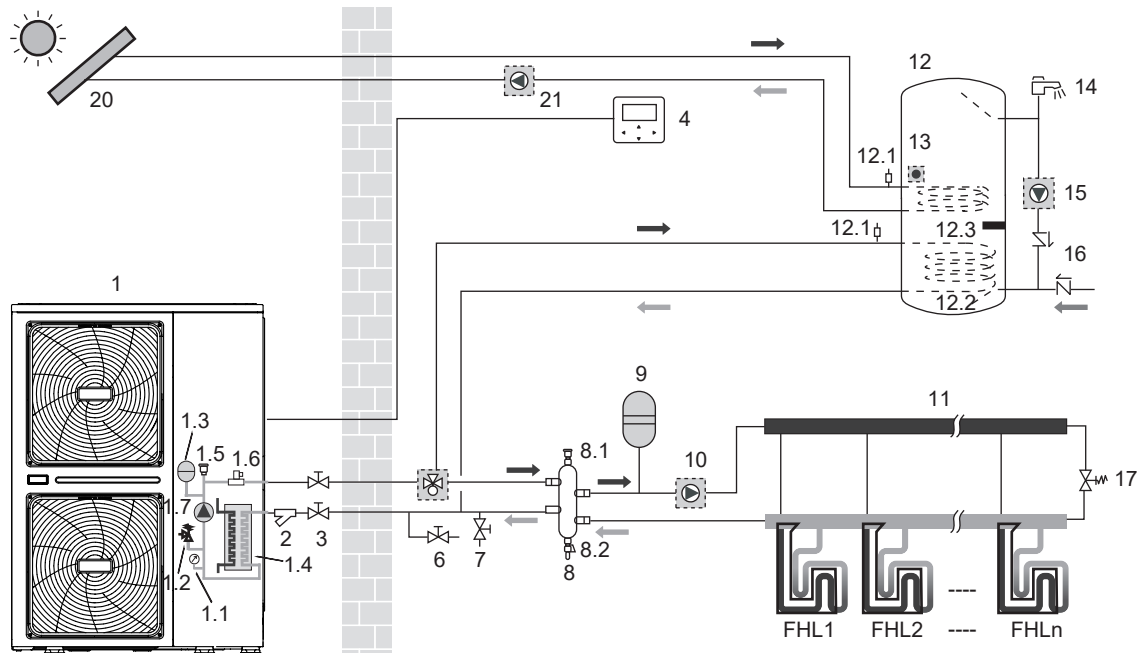

Code	Assembly unit	Code	Assembly unit
1	Heat pump	9	Expansion vessel
1.1	Pressure gauge	10	P_o: External circulation pump
1.2	Pressure relief valve	11	Manifold/distributor
1.3	Expansion vessel	12	Domestic hot water tank
1.4	Plate heat exchanger	12.1	Air purge valve
1.5	Air purge valve	12.2	Coil of heat exchanger
1.6	Flow switch	12.3	Booster heater
1.7	P_i: Circulation pump inside the unit	13	T5: DHW tank temperature sensor
2	Y-shaped filter	14	Hot water cock
3	Shut-off valve	15	P_d: DHW pump
4	Control panel	16	One-way valve
6	Discharge valve	17	Bypass valve
7	Filling valve	18	SV1: 3-way valve
8	Balance tank	20	Solar energy kit
8.1	Air purge valve	21	P_s: Solar pump
8.2	Discharge valve	FHL 1... n	Floor heating circuit

#### NOTE

The volume of the balance tank (8) must be greater than 40 L. The drain valve (6) must be installed in the lowest position of the water system. The pump (10) must be controlled by the heat pump and connected to the corresponding port of the unit (Chap. 9.7.6 Connection for other components/For the external circulation pump P\_o).



- **Operation of the circulation pump.**

The circulation pump (1.7) and (10) runs as long as the unit is on for space heating.

The circulation pump (1.7) runs as long as the appliance is on for domestic hot water (DHW) heating.

- **Space heating.**

1) The unit (1) will run to reach the water flow temperature set on the control panel.

2) The bypass valve must be selected so as to always guarantee the minimum water flow as indicated in Chap. 9.4 Water pipes.

- **Domestic hot water heating.**

1) When domestic hot water heating mode is enabled (both manually by the user and automatically by the schedule) the target temperature of the domestic hot water will be reached by a combination of coil heat exchanger and electric booster heater (when the booster heater (TBH) in the tank is set at YES).

2) When the domestic hot water temperature is lower than the setpoint configured by the user, the 3-way valve is activated to allow the heat pump to heat the domestic hot water. If there is an enormous demand for hot water or a high temperature of the hot water, the booster heater (12.3) can supply auxiliary heating.

### **CAUTION**

Make sure to install the 3-way valve correctly. For further details, see Chap. 9.7.6 Connection for other components/ For 3-way valve SV1.

### **NOTE**

The unit can be configured so that, at low outdoor temperatures, the water is only heated by the booster heater. This allows the heat pump to be available at full capacity for space heating.

Details on the configuration of the storage tank of domestic hot water for low outdoor temperatures (T4DHWMIN) can be found in 10.5 Settings on field/DHW mode setting.

### 8.6 UNITS 18-30 KW: APPLICATION 3.

Application for space heating and cooling with a room thermostat suitable for switching heating/cooling when connected to the unit. Heating is supplied by the floor heating circuits and the fan coils. Cooling is only carried out by the fan coils. Domestic hot water is supplied by the domestic hot water storage tank connected to the unit.

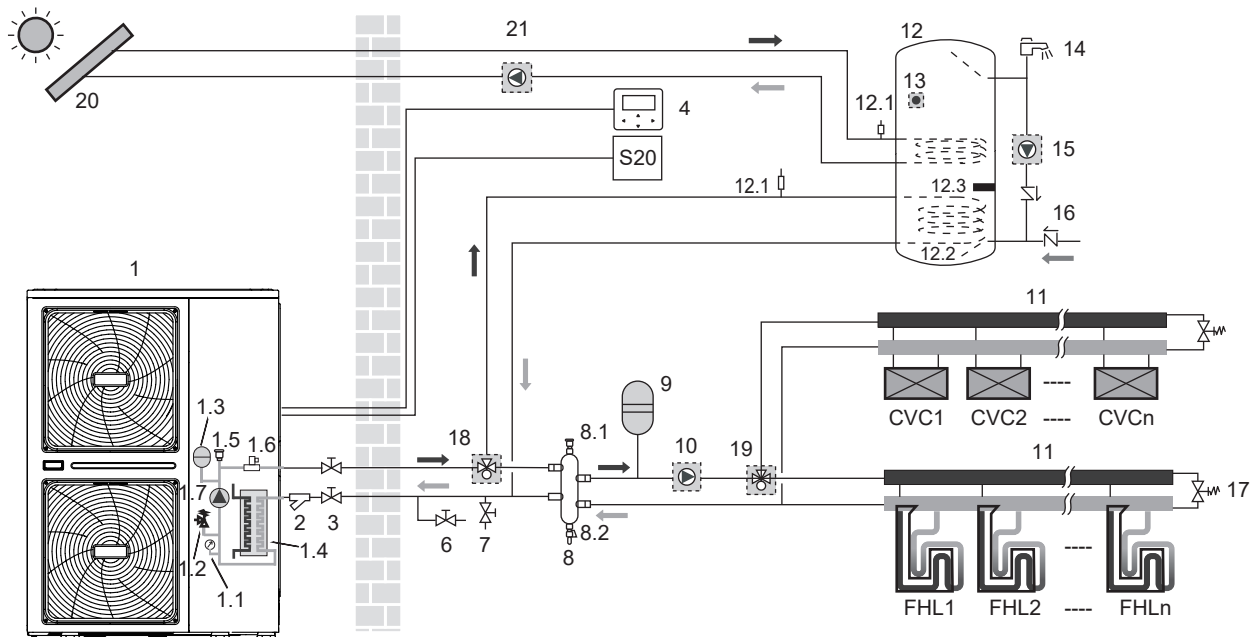

Code	Assembly unit	Code	Assembly unit
1	Heat pump	10	P_o: External circulation pump
1.1	Pressure gauge	11	Manifold/distributor
1.2	Pressure relief valve	12	Domestic hot water tank
1.3	Expansion vessel	12.1	Air purge valve
1.4	Plate heat exchanger	12.2	Coil of heat exchanger
1.5	Air purge valve	12.3	Booster heater
1.6	Flow switch	13	T5: DHW tank temperature sensor
1.7	P_i: Circulation pump inside the unit	14	Hot water cock
2	Y-shaped filter	15	P_d: DHW pump
3	Shut-off valve	16	One-way valve
4	Control panel	17	Bypass valve
S20	Room thermostat	18	SV1: 3-way valve
6	Discharge valve	19	SV2: 3-way valve
7	Filling valve	20	Solar energy kit
8	Balance tank	21	P_s: Solar pump
8.1	Air purge valve	FHL 1... n	Floor heating circuit
8.2	Discharge valve	FCU 1... n	Fan coils
9	Expansion vessel		

#### NOTE

The volume of the balance tank (8) should be greater than 40 L. The drain valve (6) should be installed in the lowest position of the system. The pump P\_o (10) must be controlled by the heat pump and connected to the corresponding port of the unit (Chap. 9.6.7 Connection for other components/For the external circulation pump P\_o).

- **Pump operation and space heating and cooling.**

The unit will switch to heating or cooling mode depending on the setting made on the room thermostat. When the room thermostat (S20) demands space heating/cooling, the pump is activated and the unit (1) switches to heating/cooling mode. The unit (1) will run to reach the required cold/hot water outlet temperature. In cooling mode, the 3-way valve (19) closes so that cold water does not flow through the floor heating circuits (FHL).

 **CAUTION**

Make sure to connect the wires of the thermostat to the correct terminals and to properly configure the ROOM THERMOSTAT in the control panel. (Chap. 10.5 Settings on field/ROOM THERMOSTAT). The room thermostat must be wired following method A according to that described in Chap. 9.7.6 Connection for other components/For the room thermostat.

The wiring of the 3-way valve (19) is different for an NC (normally closed) and NO (normally open) valve!  
Make sure to connect to the correct terminal numbers as indicated in the connection diagram.

Heating/cooling cannot be set ON/OFF from the control panel, the nominal temperature of the outlet water must be set in the control panel.

- **Domestic hot water heating.**

How domestic hot water is heated is described in Chap. 8.5 Application 2.

## 8.7 UNITS 18-30 KW: APPLICATION 4.

Application with double setpoint function with two room thermostats, connected to the unit.

- Space heating with application of two room thermostats by means of floor heating and fan coils. The floor heating circuits and the fan coils require different operating water temperatures.
- The floor heating circuits require a lower water temperature in heating mode than fan coils. A mixing kit is used to reach these two set points to adapt the water temperature based on the requirements of the floor heating circuits. The fan coils are connected directly to the water circuit of the unit and the floor heating circuits are located after the mixing kit. The mixing kit is controlled by the unit.
- The installer is in charge of operation and configuration of the water circuit on the field.
- We only offer a double setpoint control function. This function can generate two setpoints. Depending on the required water temperature (floor heating and/or fan coils are necessary). For further details, see Chap. 10.5 Settings on field/ ROOM THERMOSTAT

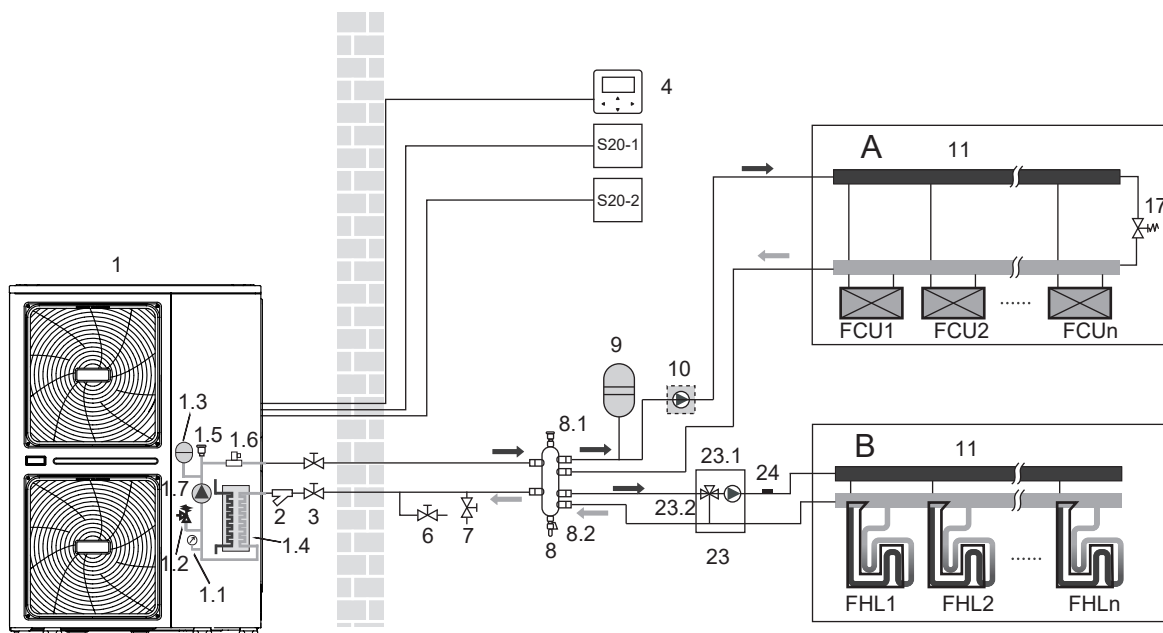

Code	Assembly unit	Code	Assembly unit
1	Heat pump	7	Filling valve
1.1	Pressure gauge	8	Balance tank
1.2	Pressure relief valve	8.1	Air purge valve
1.3	Expansion vessel	8.2	Discharge valve
1.4	Plate heat exchanger	9	Expansion vessel
1.5	Air purge valve	10	P_o: External circulation pump
1.6	Flow switch	11	Manifold/distributor
1.7	P_i: Circulation pump inside the unit	17	Bypass valve
2	Y-shaped filter	23	Mixing kit
3	Shut-off valve	23.1	P_c: Zone 2 pump
4	Control panel	23.2	SV3: 3-way valve
S20-1	Zone 1 room thermostat	24	Tw2: Zone 2 water flow temp.(optional)
S20-2	Zone 2 room thermostat	FHL 1... n	Floor heating circuit
6	Discharge valve	FCU 1... n	Fan coils

## NOTE

Wiring of the room thermostat S20-1 (for fan coils) and S20-2 (for floor supply circuits) must follow “method C” as described in Chap. 9.7.6 Connection for other components/For the room thermostat, and the thermostat that is connected to input “C” must be positioned in the zone where the floor heating circuits are installed (zone B), the other connected to input “H” must be positioned in the zone where the fan coils are installed (zone A).

## NOTE

- The volume of the balance tank (8) must be greater than 40 L. The drain valve (6) must be installed in the lowest position of the water system. The pump (10) and pump (23.1) must be controlled by the heat pump and connected to the corresponding port of the unit (Chap. 9.7.6 Connection for other components/For the external circulation pump P\_o and the feed pump P\_c).
- The advantage of the double setpoint control is that the heat pump can operate at the lowest required water flow temperature when there is only the floor heating demand. Higher water flow temperatures are only required when the fan coils are operating. This makes the heat pump more efficient.

### • Operation of the pump and space heating.

The pump (1.7) and (10) will operate when there is a heating demand from A and/or B. The pump (23.1) will only operate when there is a heating demand from B. The heat pump will start running to reach the nominal water flow temperature. The water outlet temperature depends on which room thermostat demands heating. When the room temperature of both zones is higher than the setpoint of the thermostat, the compressor and circulation pumps stop.

## NOTE

- Make sure to configure installation of the room thermostat correctly on the control panel. Chap. 10.5 Settings on field/ROOM THERMOSTAT
- The installer is in charge of making sure that no unwanted situations occur (for example high-temperature water going to the floor heating circuits, etc.).
- The double setpoint control gives you the option of using only two setpoints.
- When only zone A requires heating, zone B will be fed with water at a temperature equal to the first setpoint. This could lead to unwanted heating in zone B.
- When only zone B requires heating, the mixing kit will be fed with water at a temperature equal to the second setpoint. Depending on the mixing kit control, the floor heating circuit can still receive water at a temperature equal to the setpoint of the mixing kit.
- Keep in mind that the actual temperature of the water passing through the floor heating circuits depends on the control and setting of the mixing kit.

### 8.8 UNITS 18-30 KW: APPLICATION 5.

Application with double setpoint function without room thermostat, connected to the outdoor unit.

- Heating is supplied by the floor heating circuits and the fan coils. The floor heating circuits and the fan coils require different operating water temperatures.
- The floor heating circuits require a lower water temperature in heating mode than fan coils. A mixing kit is used to reach these two set points to adapt the water temperature based on the requirements of the floor heating circuits. The fan coils are connected directly to the water circuit of the unit and the floor heating circuits are located after the mixing kit. The mixing kit is controlled by the unit.
- The installer is in charge of operation and configuration of the water circuit on the field.
- We only offer a double setpoint control function. This function can generate two setpoints. Depending on the required water temperature (floor heating loops and/or fan coils are necessary), the first or second setpoint can be activated. (Chap. 10.5 Settings on field/Temp. Type Setting).

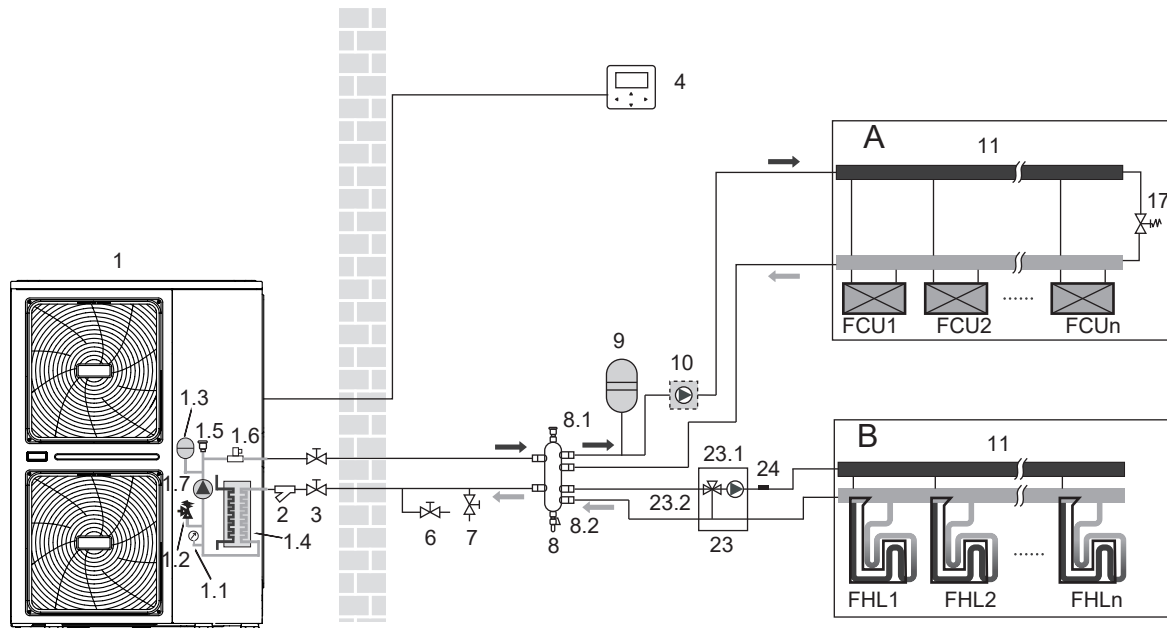

Code	Assembly unit	Code	Assembly unit
1	Heat pump	8	Balance tank
1.1	Pressure gauge	8.1	Air purge valve
1.2	Pressure relief valve	8.2	Discharge valve
1.3	Expansion vessel	9	Expansion vessel
1.4	Plate heat exchanger	10	P_o: External circulation pump
1.5	Air purge valve	11	Manifold/distributor
1.6	Flow switch	17	Bypass valve
1.7	P_i: Circulation pump inside the unit	23	Mixing kit
2	Y-shaped filter	23.1	P_c: Zone 2 pump
3	Shut-off valve	23.2	SV3: 3-way valve
4	Control panel	24	Tw2: Zone 2 water flow temp.(optional)
6	Discharge valve	FHL 1... n	Floor heating circuit
7	Filling valve	FCU 1... n	Fan coils

## NOTE

- The volume of the balance tank (8) must be greater than 40 L. The drain valve (6) must be installed in the lowest position of the water system.
- Since the temperature sensor connected in the control panel is used to detect the room temperature, the control panel (4) must be located in the room where the floor heating circuits and the fan coils are installed and far from the heating source. The correct configuration must be applied in the control panel (Chap. 10.5 Settings on field/Temp. Type Setting). The first setpoint is the water temperature that can be set on the home page of the control panel, the second setpoint is calculated based on the climatic curves, the target temperature of the outlet water is the highest of these two setpoints. The unit switches off when the room temperature reaches the target temperature.

### • **Operation of the pump and space heating.**

The pump (1.7) and (10) will operate when there is a heating demand from A and/or B. The pump (23.1) will operate when the room temperature of zone B is lower than the setpoint on the control panel. The heat pump will start running to reach the required water flow temperature.

## 8.9 UNITS 18-30 KW: CASCADE SYSTEM APPLICATION.

The units are installed in parallel and can be used for cooling, heating and hot water.

- 6 units can be connected in parallel. For the connection diagram of the electric control system of the system in parallel, refer to Chap. 9.7.5.
- The system in parallel can control and display operation of the entire system only by connecting the master to the Control panel.
- If the DHW function is required, the water tank can be connected to the water circuit of the master unit only through a 3-way valve, and controlled by the master unit.
- The connection and the function of the terminal are the same as the single unit. Please refer to application 8.1-8.6.

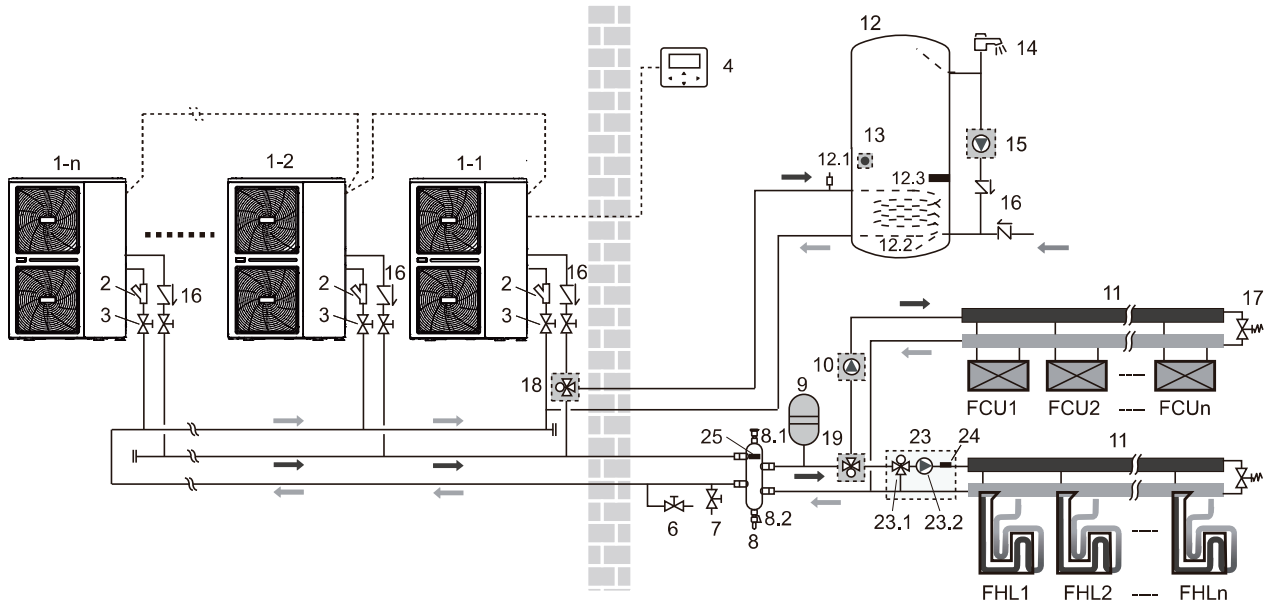

Code	Assembly unit	Code	Assembly unit
1-1	Heat pump: master	12.3	Booster heater
1-2...1-n	Heat pump: slave	13	T5: DHW tank temperature sensor
2	Y-shaped filter	14	Hot water cock
3	Shut-off valve	15	P_d: DHW pump
4	Control panel	16	One-way valve
6	Discharge valve	17	Bypass valve
7	Filling valve	18	SV1: 3-way valve
8	Balance tank	19	SV2: 3-way valve
8.1	Air purge valve	23	Mixing kit
8.2	Discharge valve	23.1	SV3: 3-way valve
9	Expansion vessel	23.2	P_c: Zone 2 pump
10	P_o: External circulation pump	24	Tw2: Zone 2 water flow temp.(optional)
11	Manifold/distributor	25	Tbt1: Temperature sensor, balance tank (optional)
12	Domestic hot water tank	FHL 1... n	Floor heating circuit
12.1	Air purge valve	FCU 1... n	Fan coils
12.2	Coil of heat exchanger		



## NOTE

- The volume of the balance tank (8) should be greater than 40 L. The drain valve (6) should be installed in the lowest position of the system.
- The junctions of the water inlet and outlet pipes of each unit of the parallel system should be connected with soft fittings, and the one-way valves must be installed on the water outlet pipe.
- The temperature sensor Tbt1 must be installed in the parallel system (otherwise the unit cannot be started), the temperature point is set in the balance tank (8).

# 9 OVERVIEW OF THE UNIT.

## 9.1 DISASSEMBLING THE UNIT.

### Models 4-16 kW.

Door 1 To access the compressor, the electric parts and the hydraulic compartment

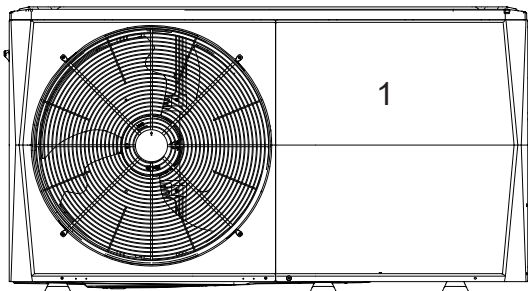

4/6kW

Door 1 To access the compressor and the electric components

Door 2 To access the hydraulic compartment and the electric components

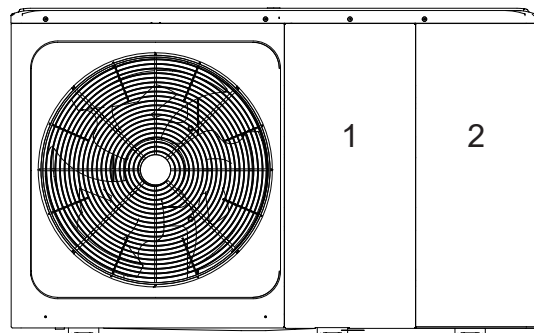

8/10/12/14/16kW

## WARNING

- Before removing doors 1 and 2, disconnect power to the unit and the domestic hot water storage tank (if applicable).
- The components inside the unit could be hot.

### Models 18-30 kW.

Door 1 To access the compressor, the electric parts and the hydraulic compartment

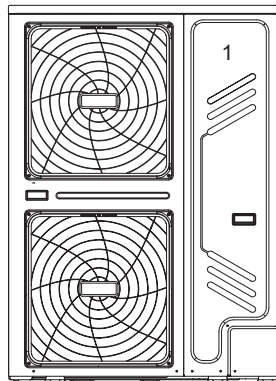

## WARNING

- Before removing door 1, switch off all the supplies of the unit.
- The components inside the unit could be hot.

Push the grille to the left until it stops, then pull the right border to remove it. You may also invert the procedure. Pay attention not to injure your hands.

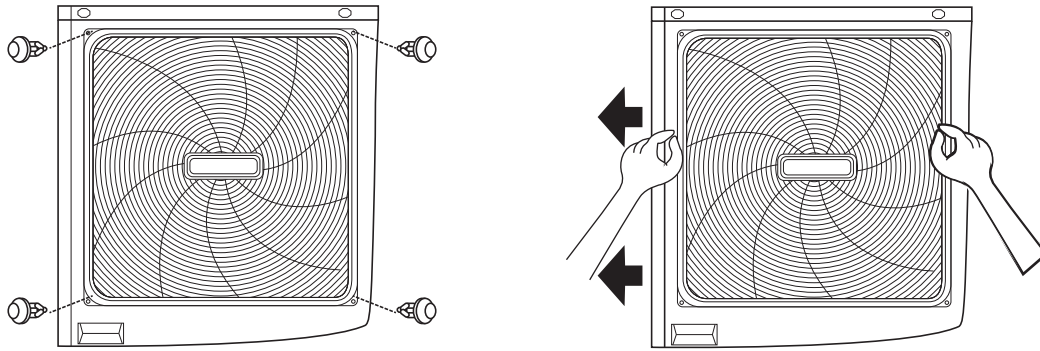

## 9.2 MAIN COMPONENTS

Hydraulic module 4-6 kW and 8-16 kW.

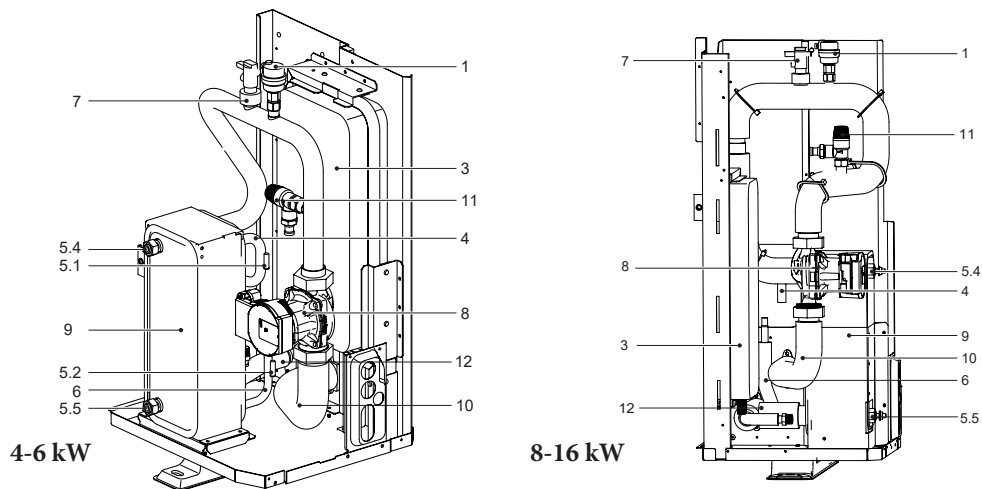

Code	Assembly unit	Explanation
1	Automatic air purge valve	The residual air in the water circuit will be removed automatically from the water circuit.
3	Expansion vessel	Balances the pressure of the water system.
4	Refrigerant gas pipe	-
5	Temperature sensors	Four temperature sensors determine the temperature of the water and of the refrigerant at the various points of the water circuit. 5.1-T2B; 5.2-T2; 5.3-T1(optional); 5.4-TW_out; 5,5-TW_in.
6	Refrigerant liquid pipe	-
7	Flow switch	Detects the water flow rate to protect the compressor and the water pump in case of insufficient water flow.
8	Pump	Circulates the water in the water circuit.
9	Plate heat exchanger	Transfers the heat of the refrigerant to the water.
10	Water outlet pipe	-
11	Pressure relief valve	Prevents overpressure of the water by opening at 3 bar and draining water from the water circuit.
12	Water inlet pipe	-

Hydraulic module 18-30 kW.

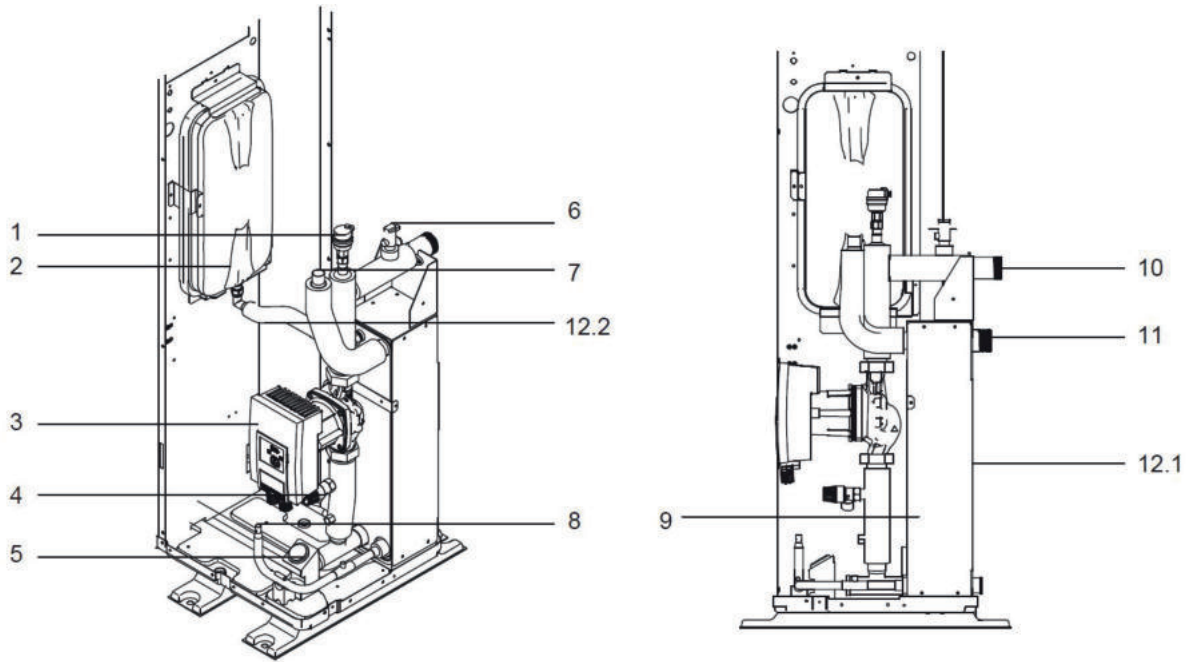
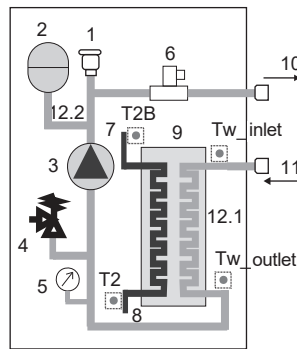

Diagram of hydraulic system 18-30 kW.



Code	Assembly unit	Explanation
1	Automatic air purge valve	The air left in the water circuit will be removed automatically from the water circuit.
2	Expansion vessel	Balances the pressure of the water system. (Volume of expansion vessel 8 L)
3	Circulation pump	Circulates the water in the water circuit.
4	Pressure relief valve	Prevents overpressure of the water by opening at 3 bar and draining water from the water circuit.
5	Pressure gauge	Revise the pressure reading of the water circuit
6	Flow switch	Detects the water flow rate to protect the compressor and the water pump in case of insufficient water flow.
7	Refrigerant gas connection	-
8	Refrigerant liquid connection	-
9	Plate heat exchanger	Transfers the heat of the refrigerant to the water.
10	Water outlet connection	-
11	Water inlet connection	-
12.1	Electrical heating tape	For heating plates heat exchanger
12.2	Electrical heating tape	For the connection pipe heating the expansion vessel.
/	Temperature sensors	Four temperature sensors determine the temperature of the water and of the refrigerant at the various points of the water circuit. (T2B; T2; TW_out; TW_in).

### 9.3 ELECTRONIC CONTROL BOX.

Models 4-6 kW.

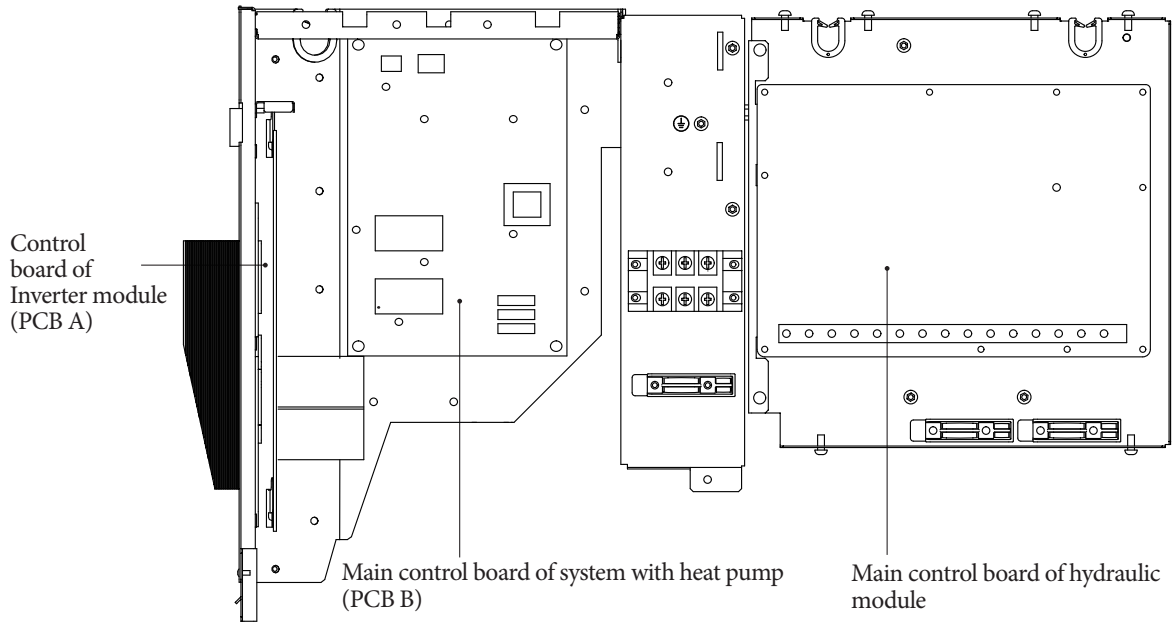

8 kW model.

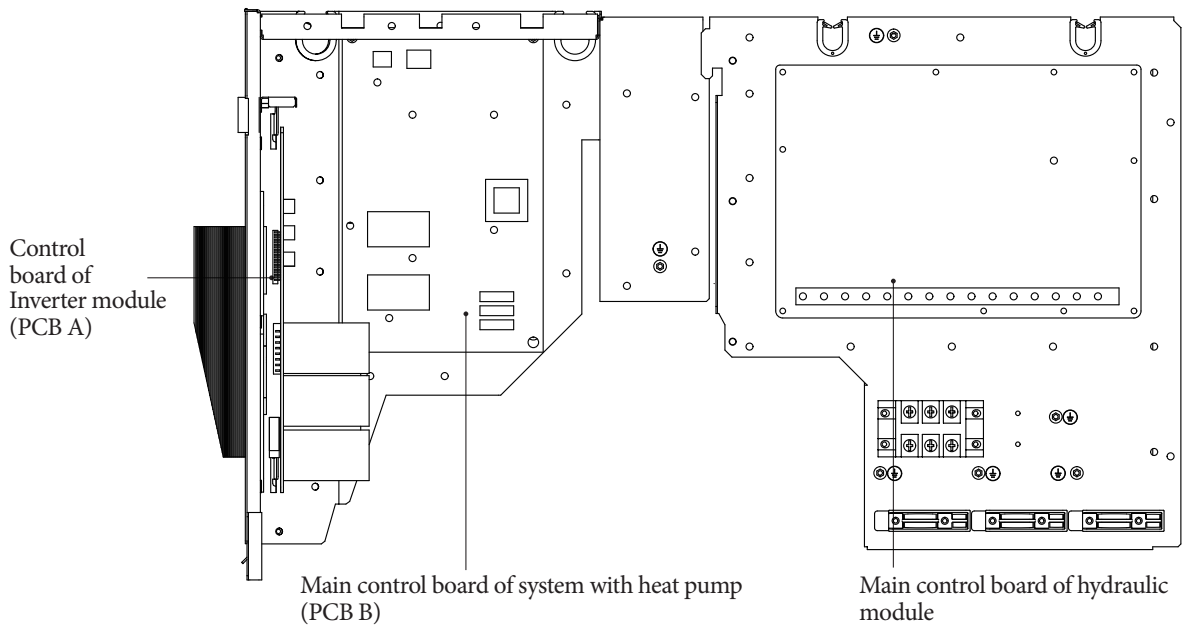

Single phase models 12-14-16 kW.

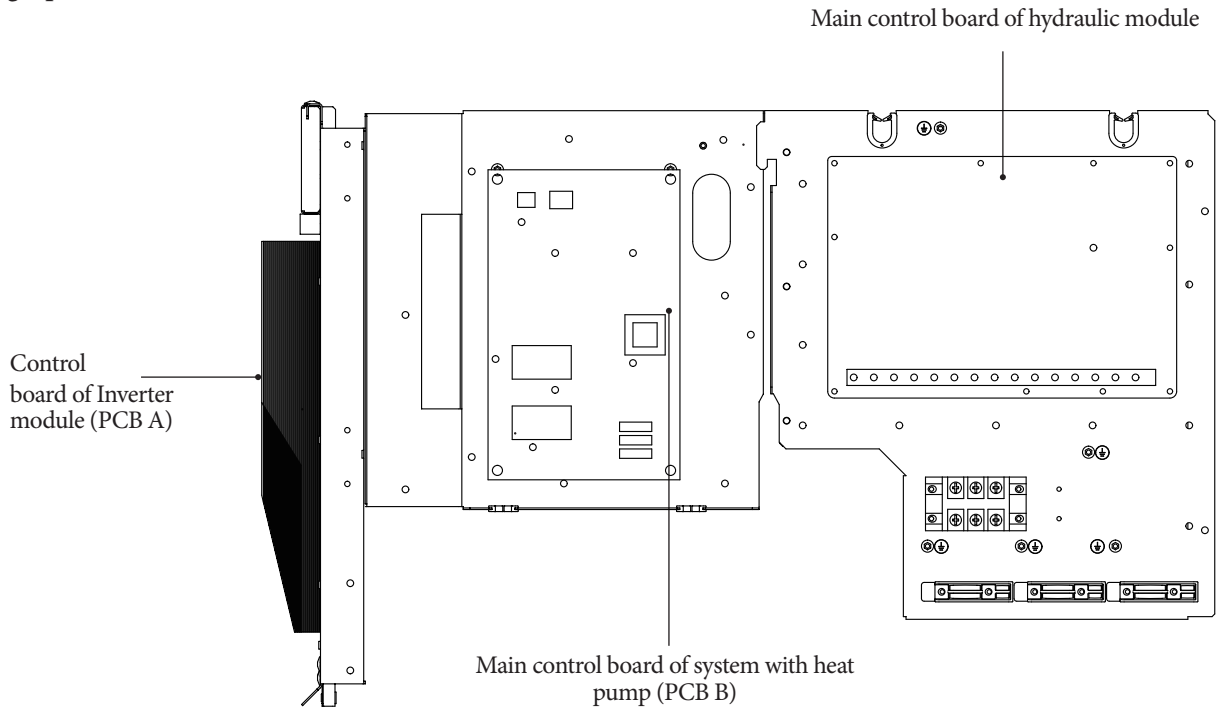

Three-phase models 12-14-16 kW.

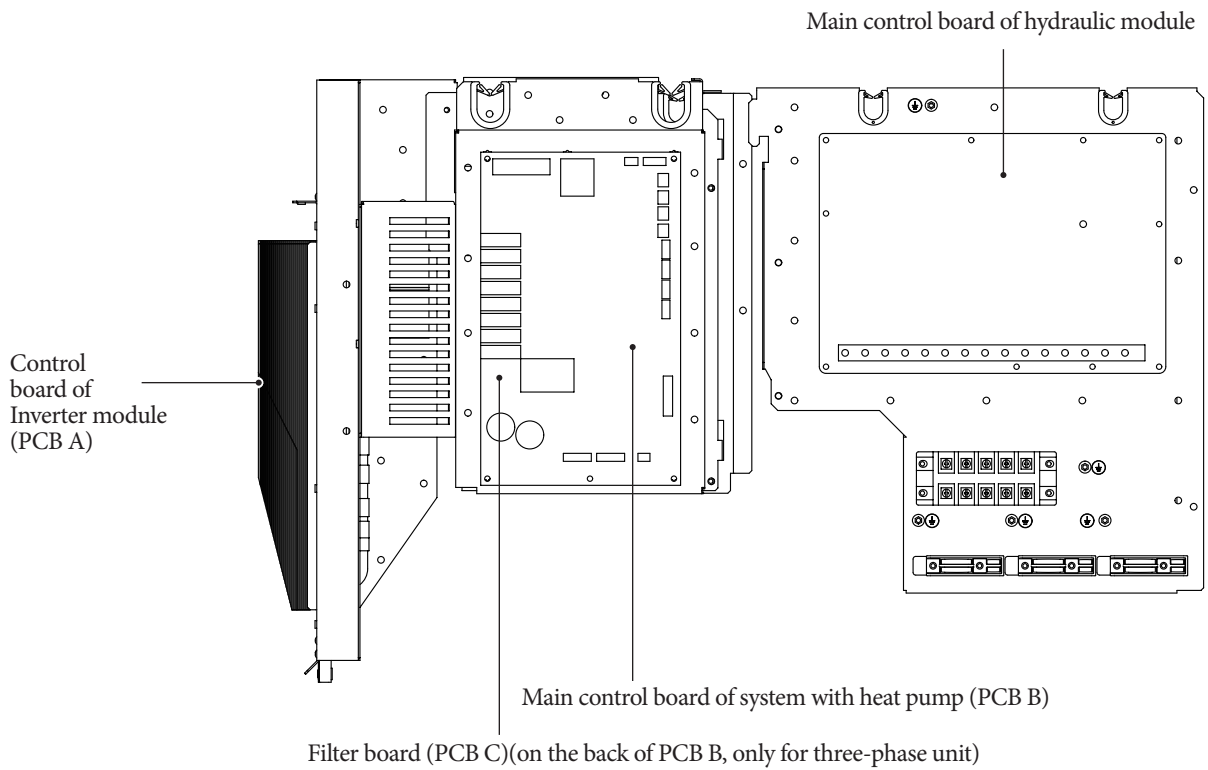

Models 18-30 kW.

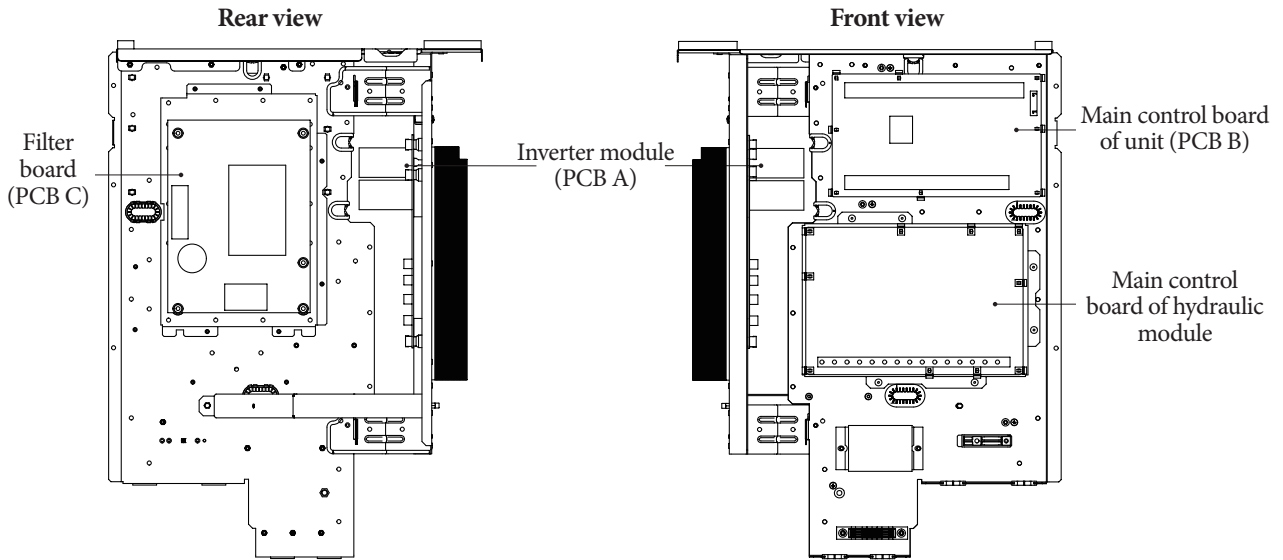

9.3.1 Main control panel of hydraulic module.

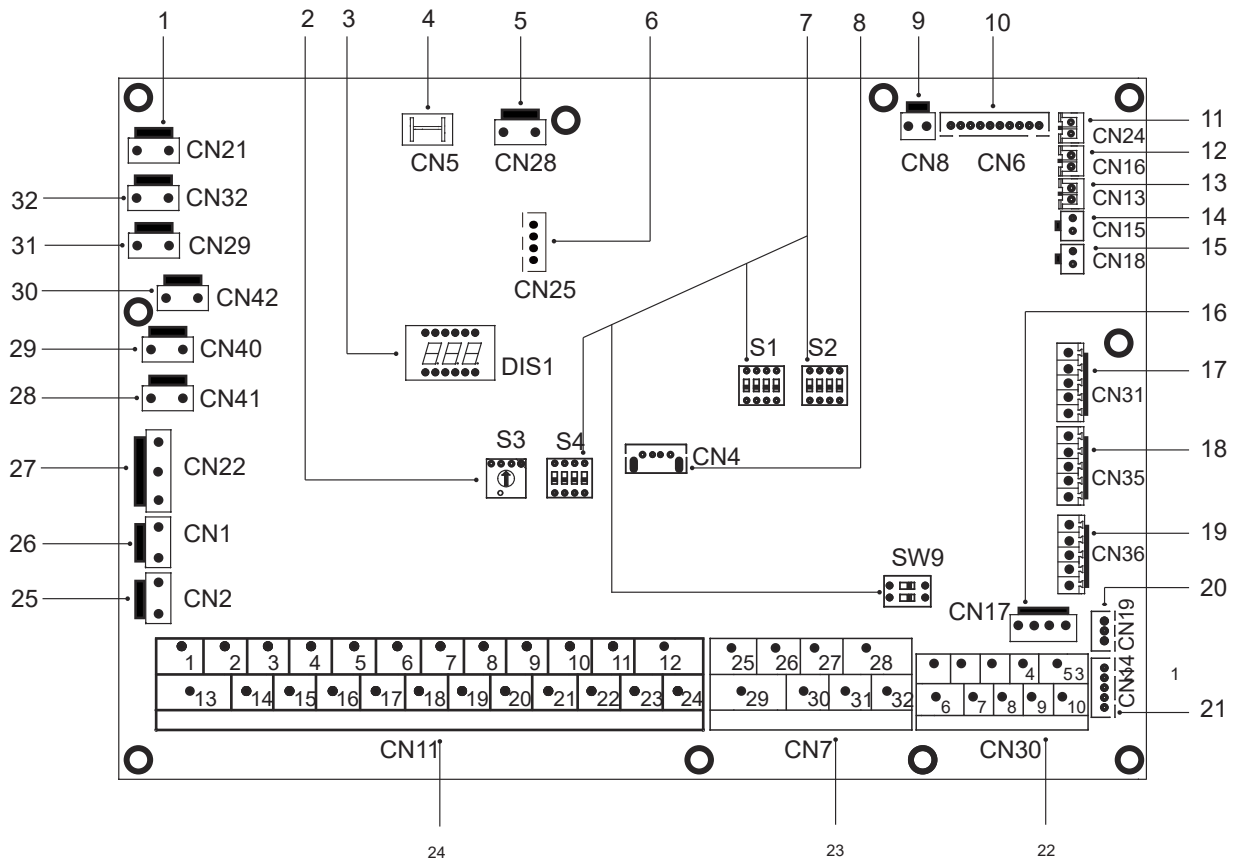

Order	Port	Code	Assembly unit
1	CN21	POWER	Power supply port
2	S3	-	Not used
3	DIS1	-	Digital display
4	CN5	EARTH	Earth port
5	CN28	PUMP	Variable speed pump power input port
6	CN25	DEBUG	IC programming port
7	S1,S2,S4,SW9	-	DIP Switch
8	CN4	USB	USB programming port
9	CN8	FS	Flow switch port
10	CN6	T2	Port for refrigerant liquid side temperature sensors, internal unit temperature (heating mode)
		T2B	Port for refrigerant gas side temperature sensors, internal unit temperature (cooling mode)
		TW_in	Port for inlet water temperature sensors of plate heat exchanger
		TW_out	Port for outlet water temperature sensors of plate heat exchanger
		T1	Port for outlet water final temperature sensors of outdoor unit
11	CN24	Tbt1	Port for upper temperature sensor of balance tank
12	CN16	Tbt2	Not used
13	CN13	T5	Port for domestic hot water temperature sensor
14	CN15	Tw2	Port for outlet water of zone 2 temperature sensor
15	CN18	Tsolar	Port for solar panel lower temperature sensor
16	CN17	PUMP_BP	Port for variable speed pump communication
17	CN31	HT	Room thermostat control port (heating mode)
		COM	Room thermostat power supply port
		CL	Room thermostat control port (cooling mode)
18	CN35	SG	SMART GRID port (grid signal)
		EVU	SMART GRID port (photovoltaic signal)
19	CN36	M1 M2	Port for remote switch
		T1 T2	Not used
20	CN19	P Q	Not used
21	CN14	A B X Y E	Port for communication with control panel
22	CN30	1 2 3 4 5	Port for communication with control panel
		6 7	Not used
		9 10	Port for machines in cascade
23	CN7	26 30/31 32	Compressor operation/Defrost operation
		25 29	Not used
		27 28	Port for additional heating source
24	CN11	1 2	Solar energy input port
		3 4 15	Room thermostat port
		5 6 16	Port for SV1 (3-way valve)
		7 8 17	Port for SV2 (3-way valve)
		9 21	Port for zone 2 pump
		10 22	Port for external circulation pump
		11 23	Port for solar energy pump
		12 24	Port for DHW pipes pump
		13 16	Control port for TBH DHW booster heater
		14 17	Port for indoor unit backup heater
18 19 20	Port for SV3 (3-way valve)		
25	CN2	TBH_FB	Feedback port for external thermostat (in default short-circuit)

Order	Port	Code	Assembly unit
26	CN1	IBH1/2_FB	Feedback port for thermostat (in default short-circuit)
27	CN22	IBH1	Port for backup heater
		IBH2	Reserved
		TBH	Control port for tank booster heater
28	CN41	HEAT8	Port for anti-freeze electric heating tape (internal)
29	CN40	HEAT7	Port for anti-freeze electric heating tape (internal)
30	CN42	HEAT6	Port for anti-freeze electric heating tape (internal)
31	CN29	HEAT5	Port for anti-freeze electric heating tape (internal)
32	CN32	IBH0	Port for backup heater

### 9.3.2 Single phase for units 4-16 kW.

#### 1) PCB A, 4-8kW, Inverter module

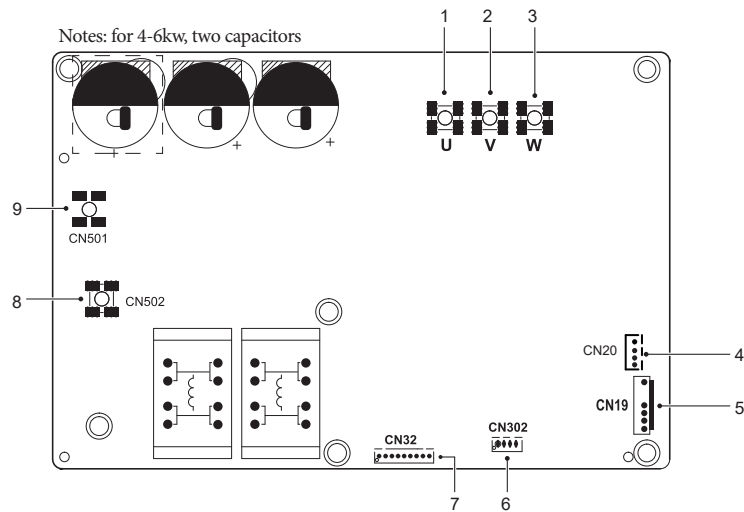

Code	Assembly unit	Code	Assembly unit
1	U compressor connection port	6	Reserved (CN302)
2	V compressor connection port	7	Port for communication with PCB B (CN32)
3	W compressor connection port	8	Input port N for rectifier jumper (CN502)
4	Output port for +12V/9V (CN20)	9	Input port L for rectifier jumper (CN501)
5	Fan port (CN19)	/	/



2) PCB A, 12-16kW, Inverter module

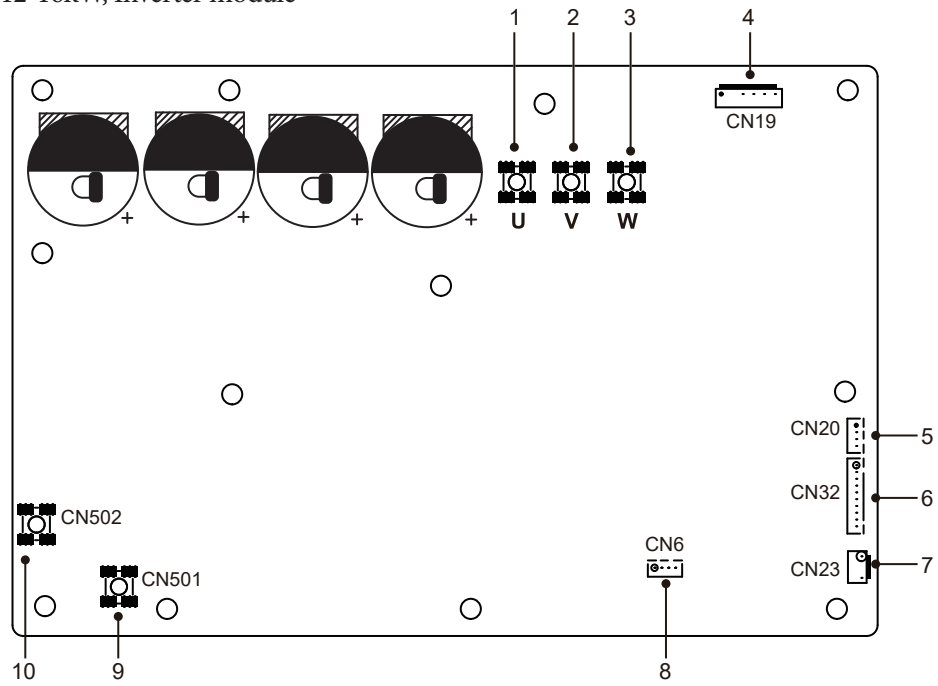

Code	Assembly unit	Code	Assembly unit
1	U compressor connection port	6	Port for communication with PCB B (CN32)
2	V compressor connection port	7	Port for high pressure switch (CN23)
3	W compressor connection port	8	Reserved (CN6)
4	Fan port (CN19)	9	Input port N for rectifier jumper (CN502)
5	Output port for +12V/9V (CN20)	10	Input port L for rectifier jumper (CN501)

### 3) PCB B, main control board of heat pump system

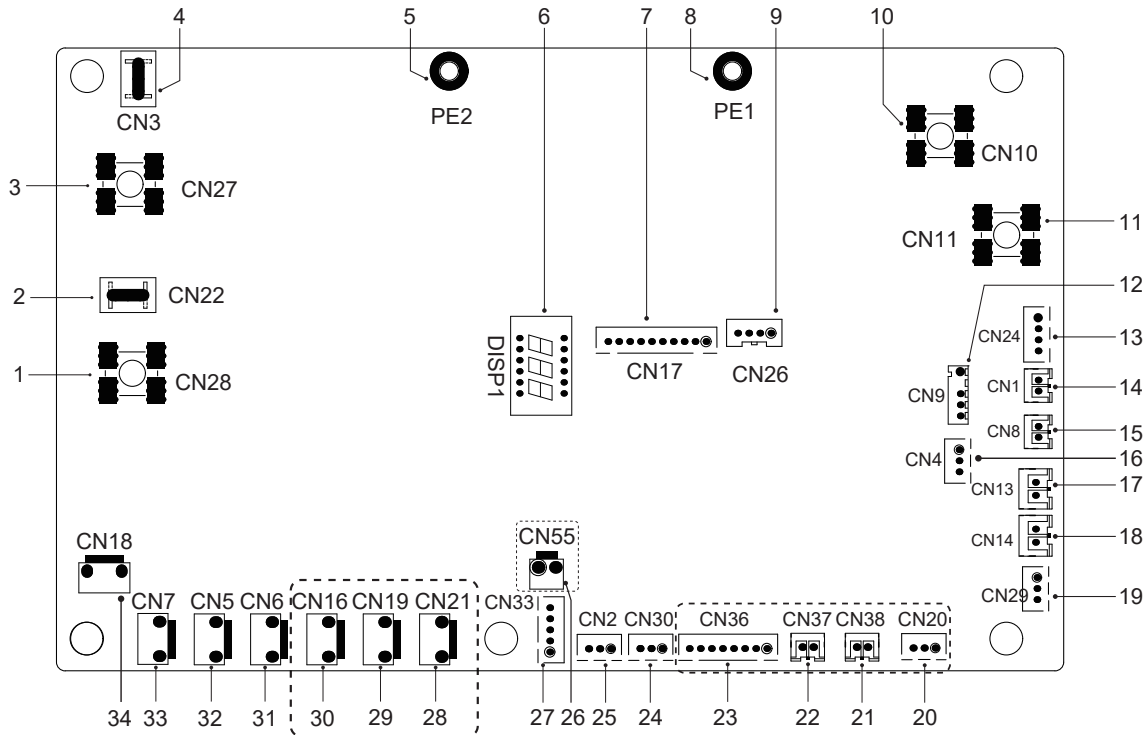

Code	Assembly unit	Code	Assembly unit
1	Output port L to PCB A (CN28)	18	Port for low pressure switch (CN14)
2	Reserved (CN22)	19	Port for communication with hydro-box control board (CN29)
3	Output port L to PCB A (CN27)	20	Reserved (CN20)
4	Reserved (CN3)	21	Reserved (CN38)
5	Port for earth cable (PE2)	22	Reserved (CN37)
6	Digital display (DSP1)	23	Reserved (CN36)
7	Port for communication with PCB A (CN17)	24	Port for communication (reserved CN30)
8	Port for earth cable (PE1)	25	Port for communication (reserved CN2)
9	Reserved (CN26)	26	Reserved (CN55)
10	Input port for neutral cable (CN10)	27	Port for electric expansion valve (CN33)
11	Input port for live cable (CN11)	28	Reserved (CN21)
12	Port for external room temperature sensor and condenser temperature sensor (CN9)	29	Reserved (CN19)
13	Output port for +12V/9V (CN24)	30	Port for frame electric heating tape (CN16) (optional)
14	Port for intake temperature sensor (CN1)	31	Port for 4-way valve (CN6)
15	Port for drain temperature sensor (CN8)	32	Port for SV6 valve (CN5)
16	Port for pressure sensor (CN4)	33	Port for compressor 1 electric heating tape (CN7)
17	Port for high pressure switch (CN13)	34	Port for compressor 2 electric heating tape (CN18)

### 9.3.3 Three phase for units 12-14-16 kW.

#### 1) PCB A, inverter module

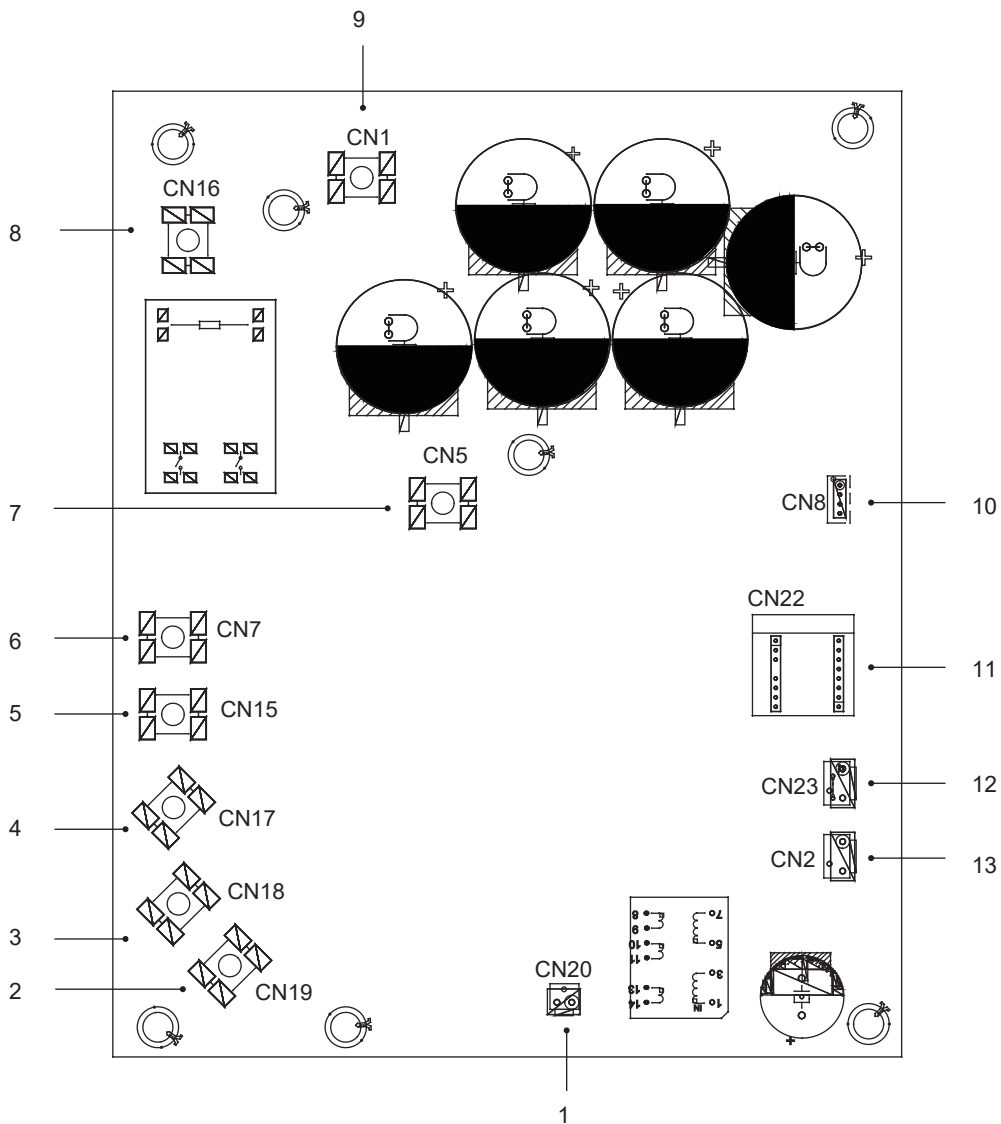

Code	Assembly unit	Code	Assembly unit
1	Output port for +15V (CN20)	8	L1 power supply input port (CN16)
2	W compressor connection port (CN19)	9	P_in input port for IPM module (CN1)
3	V compressor connection port (CN18)	10	Port for communication with PCB B (CN8)
4	U compressor connection port (CN17)	11	PED board (CN22)
5	L3 power supply input port (CN15)	12	Port for high pressure switch (CN23)
6	L2 power supply input port (CN7)	13	Port for communication with PCB C (CN2)
7	Input port P_out for IPM module (CN5)		

2) PCB B, main control board of heat pump system

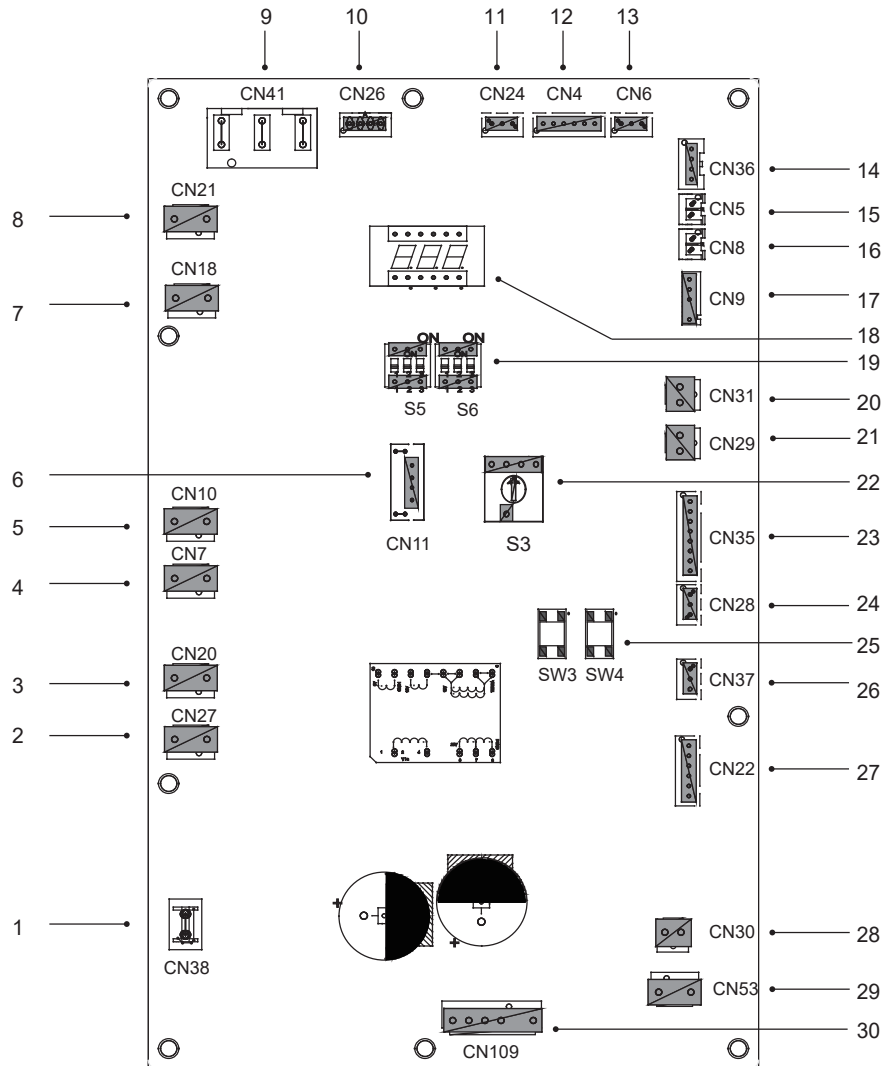

Code	Assembly unit	Code	Assembly unit
1	Port for earth cable (CN38)	16	Port for T <sub>p</sub> temperature sensor (CN8)
2	Port for 2-way valve 6 (CN27)	17	Port for external room temperature sensor and condenser temperature sensor (CN9)
3	Port for 2-way valve 5 (CN20)	18	Digital display (DSP1)
4	Port for electric heating tape 2 (CN7)	19	Dip switch (SS.S6)
5	Port for electric heating tape 1 (CN10)	20	Port for low pressure switch (CN31)
6	Reserved (CN11)	21	Port for high pressure switch and quick check (CN29)
7	Port for 4-way valve (CN18)	22	Rotary Dip switch (S3)
8	Reserved (CN21)	23	Port for temperature sensors (TW_out; TW_in; T1; T2; T2B) (CN35) (Reserved)
9	Power supply port from PCB C (CN41)	24	Port for XYE communication (CN28)
10	Port for communication with power meter (CN26)	25	Keys for forced cooling and control (S3, S4)
11	Port for communication with hydro-box control board (CN24)	26	Port for H1H2E communication (CN37)
12	Port for communication with PCB C (CN4)	27	Port for electric expansion valve (CN22)
13	Port for pressure sensor (CN6)	28	Port for fan 15VDC power supply (CN30)
14	Port for communication with PCB A (CN36)	29	Port for fan 31VDC power supply (CN53)
15	Port for T <sub>h</sub> temperature sensor (CN5)	30	Fan port (CN109)

3) PCB C, Three-phase filter board 12/14/16 kW

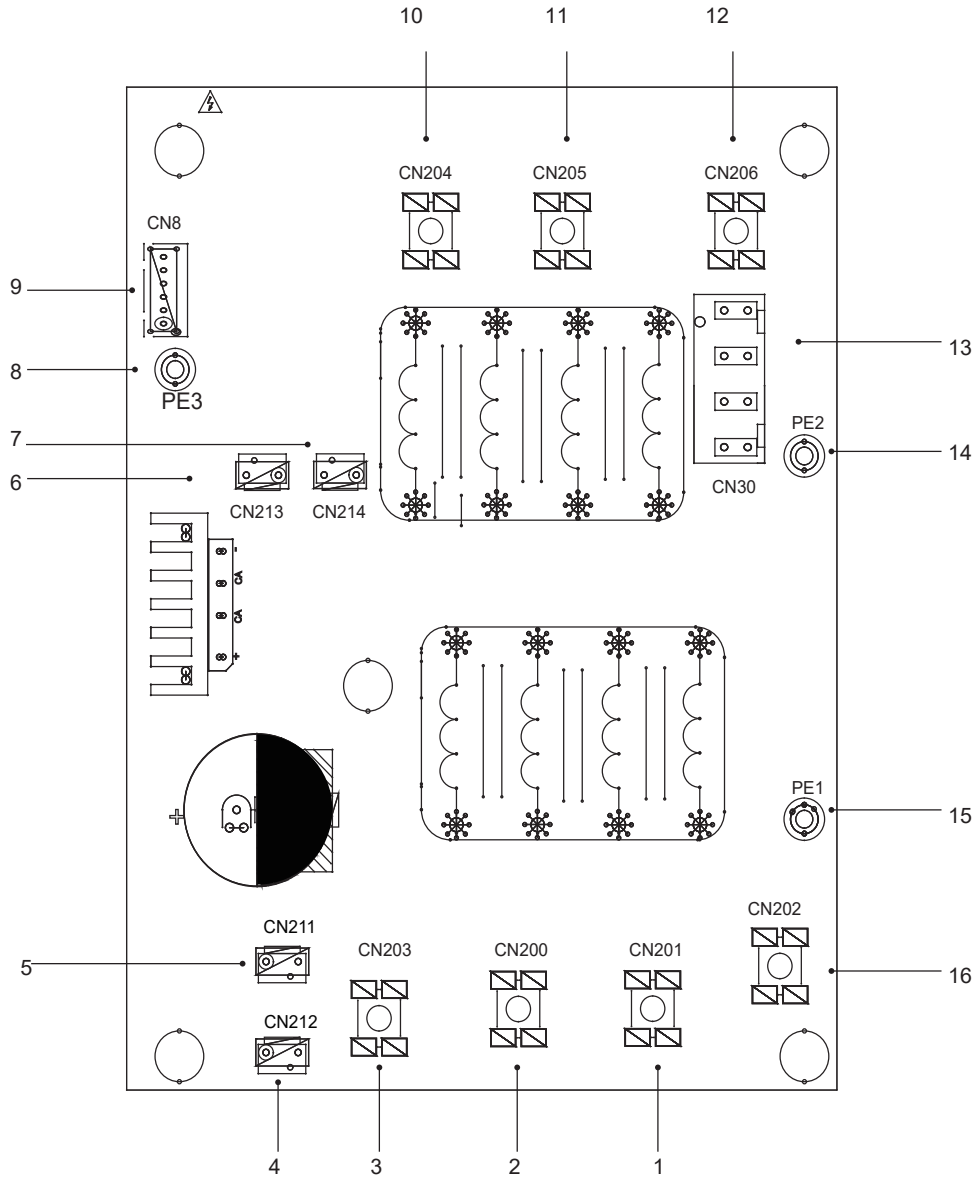

Code	Assembly unit	Code	Assembly unit
1	L2 power supply (CN201)	9	Port for communication with PCB B (CN8)
2	L3 power supply (CN200)	10	L3 filtering power (L3)
3	N power supply (CN203)	11	L2 filtering power (L2)
4	31VDC power supply port (CN212)	12	L1 filtering power (L1)
5	Reserved (CN211)	13	Power supply port for main control board (CN30)
6	Port for fan reactor (CN213)	14	Port for earth cable (PE2)
7	Power supply port for Inverter module (CN214)	15	Port for earth cable (PE1)
8	Earth cable (PE3)	16	L1 power supply (L1)

Inverter module 18-30 kW

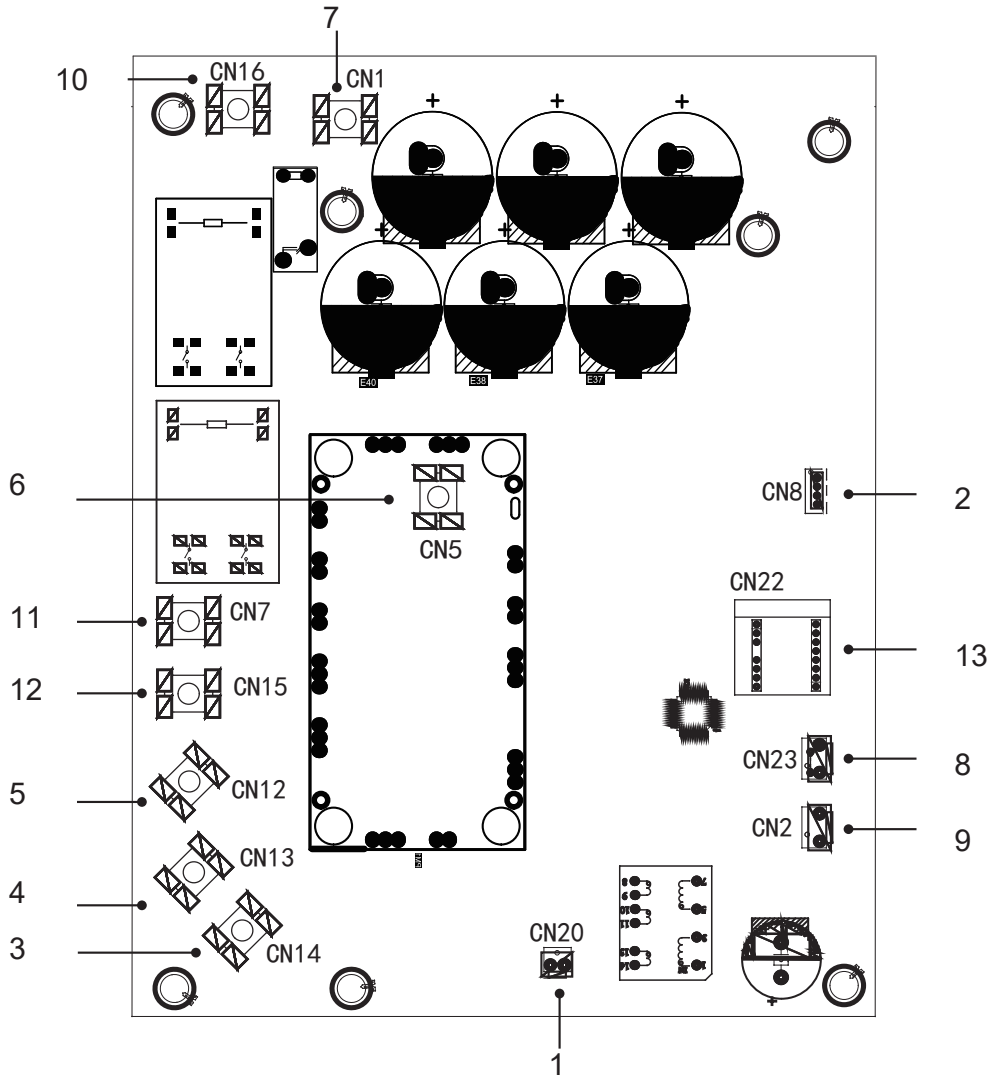

Code	Assembly unit
1	Output port for +15V (CN20)
2	Port for communication with PCB B (CN8)
3	W compressor connection port
4	V compressor connection port
5	U compressor connection port
6	Input port P_out for IPM module
7	Input port P_in for IPM module
8	Input port for high pressure switch (CN23)
9	Port for power supply change (CN2)
10	L1 filtering port (L1)
11	L2 filtering port (L2)
12	L3 filtering port (L3)
13	PED board

Main control board units 18-30 kW

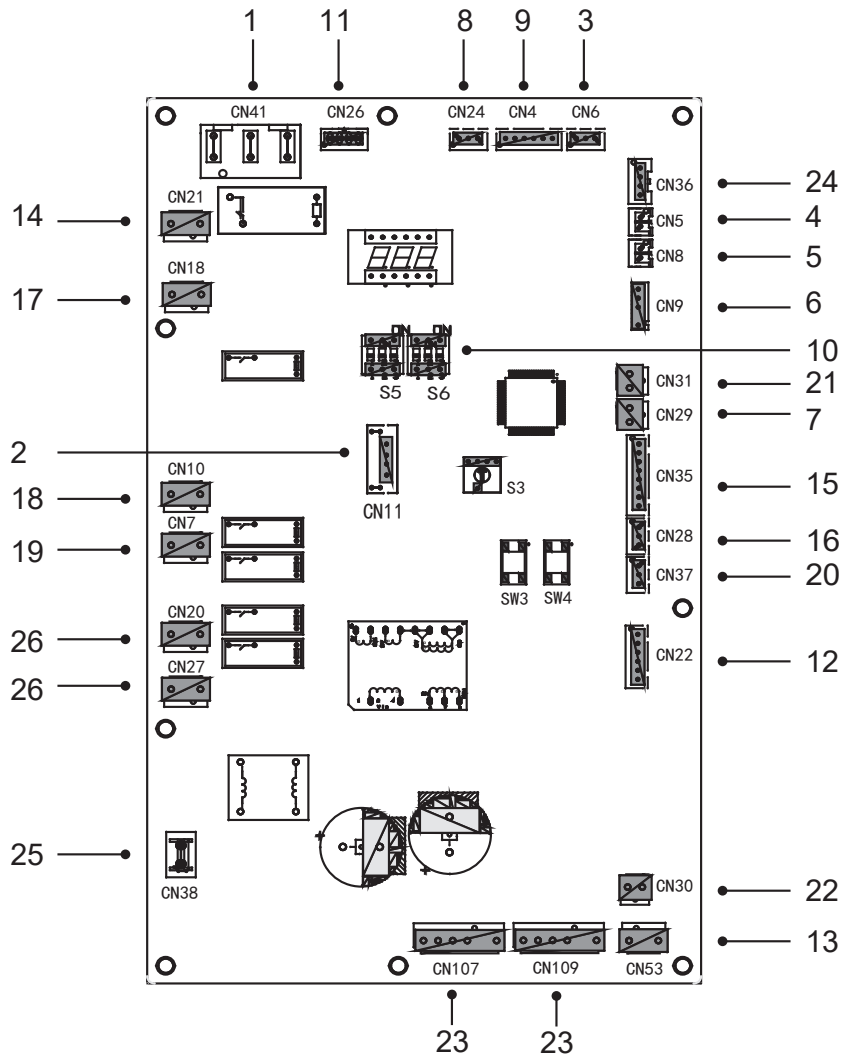

Code	Assembly unit	Code	Assembly unit
1	Power supply port for PCB B (CN41)	14	Power supply port for hydro-box control board (CN21)
2	IC programming port (CN11)	15	Port for another temperature sensor (CN35)
3	Port for pressure sensor (CN6)	16	Port for XYE communication (CN28)
4	Port for intake temperature sensor (CN5)	17	Port for 4-way valve (CN18)
5	Port for drain temperature sensor (CN8)	18	Port for electric heating tape 1 (CN10)
6	Port for external room temperature sensor and condenser temperature sensor (CN9)	19	Port for electric heating tape 2 (CN7)
7	Port for low pressure switch and quick check (CN29)	20	Port for D1D2E communication (CN37)
8	Port for communication with hydro-box control board (CN24)	21	Port for high pressure switch and quick check (CN31)
9	Port for communication with PCB C (CN4)	22	Port for fan 15VDC power supply (CN30)
10	Dip Switch (S5, S6)	23	Fan port (CN107/109)
11	Port for communication with power meter (CN26)	24	Port for communication with PCB A (CN36)
12	Port for electric expansion valve (CN22)	25	GND port (CN38)
13	Port for fan 31VDC power supply (CN53)	26	SV port (CN20/27)

18-30 kW units filter board

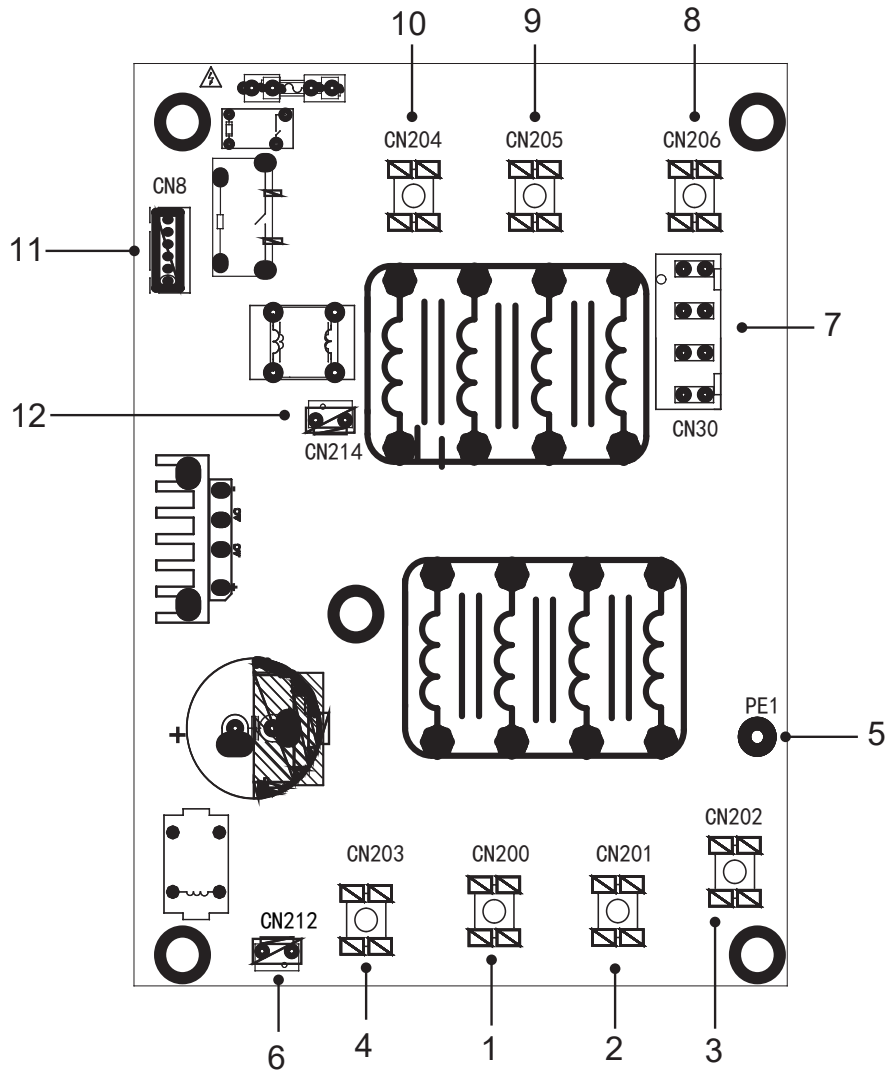

Code	Assembly unit	Code	Assembly unit
1	L3 power supply (L3)	7	Power supply port for main control board (CN30)
2	L2 power supply (L2)	8	L1 filtering power (L1)
3	L1 power supply (L1)	9	L2 filtering power (L2)
4	N power supply (N)	10	L3 filtering power (L3)
5	Earth cable (PE1)	11	Port for communication with PCB B (CN8)
6	Power supply port for CC fan (CN212)	12	PCB A switch on power supply (CN214)



# Wiring diagram for units 4-8 kW

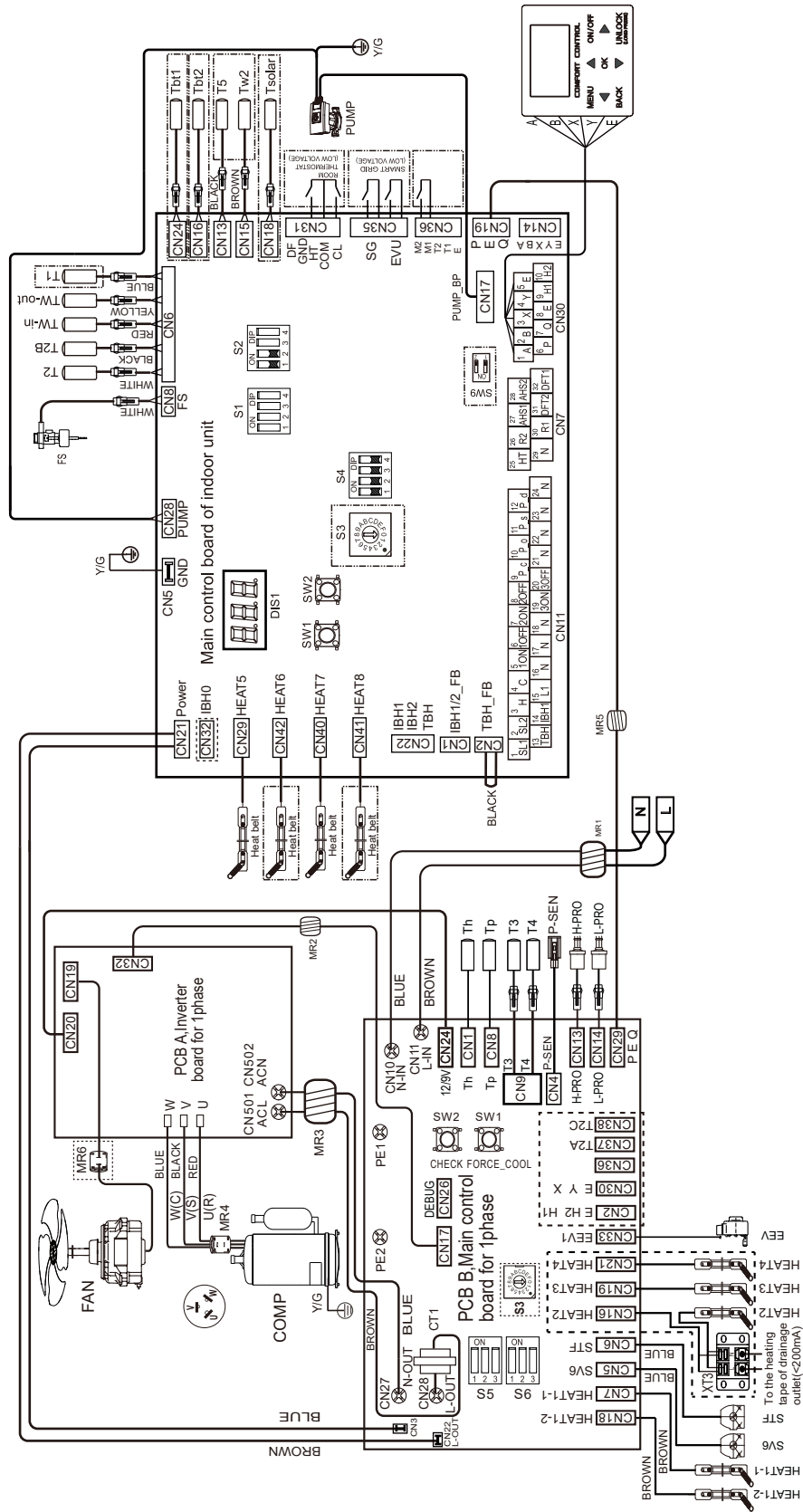

# Wiring diagram for units 12-16 kW

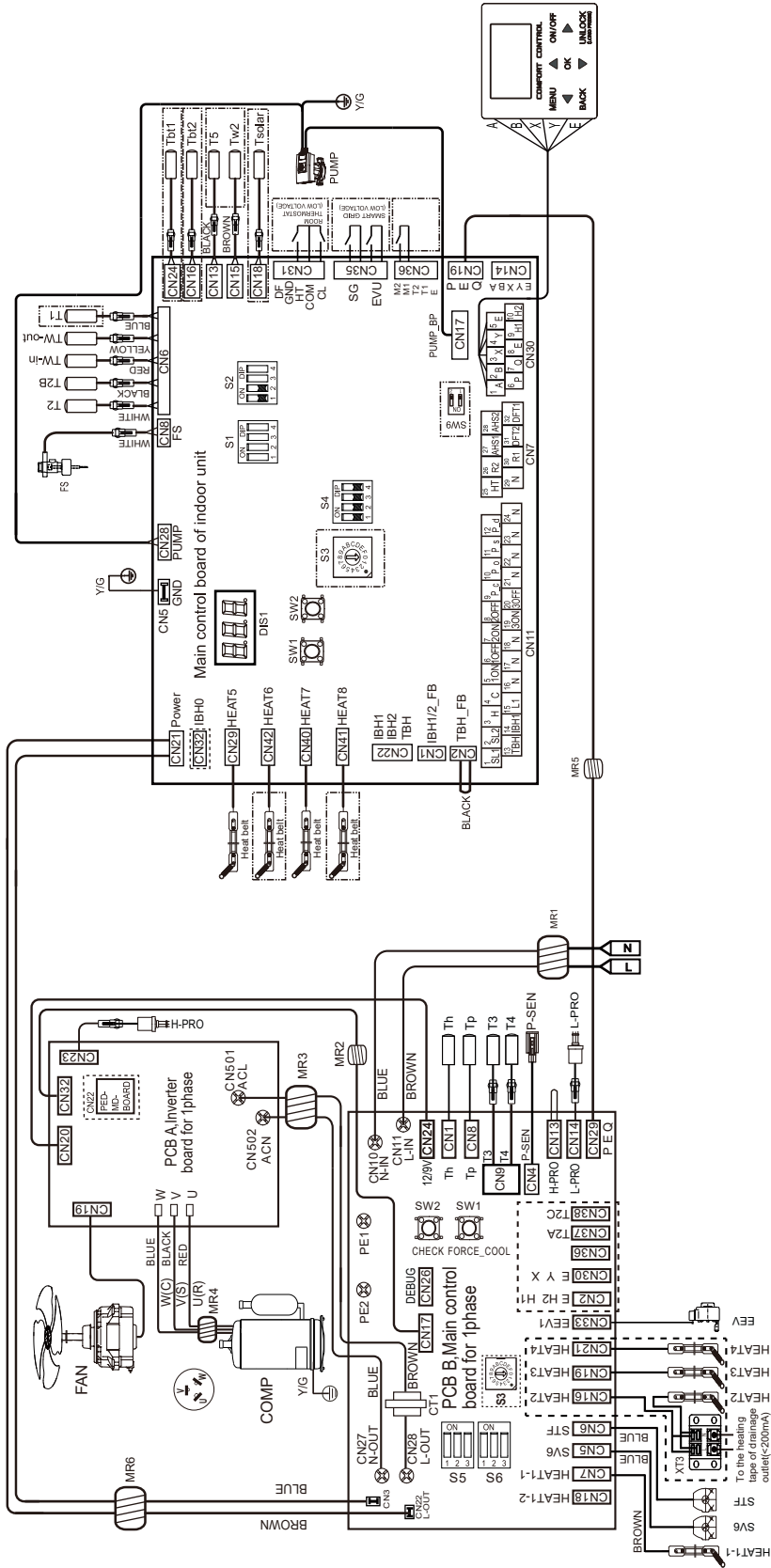

# Wiring diagram for units 12-16 kW T

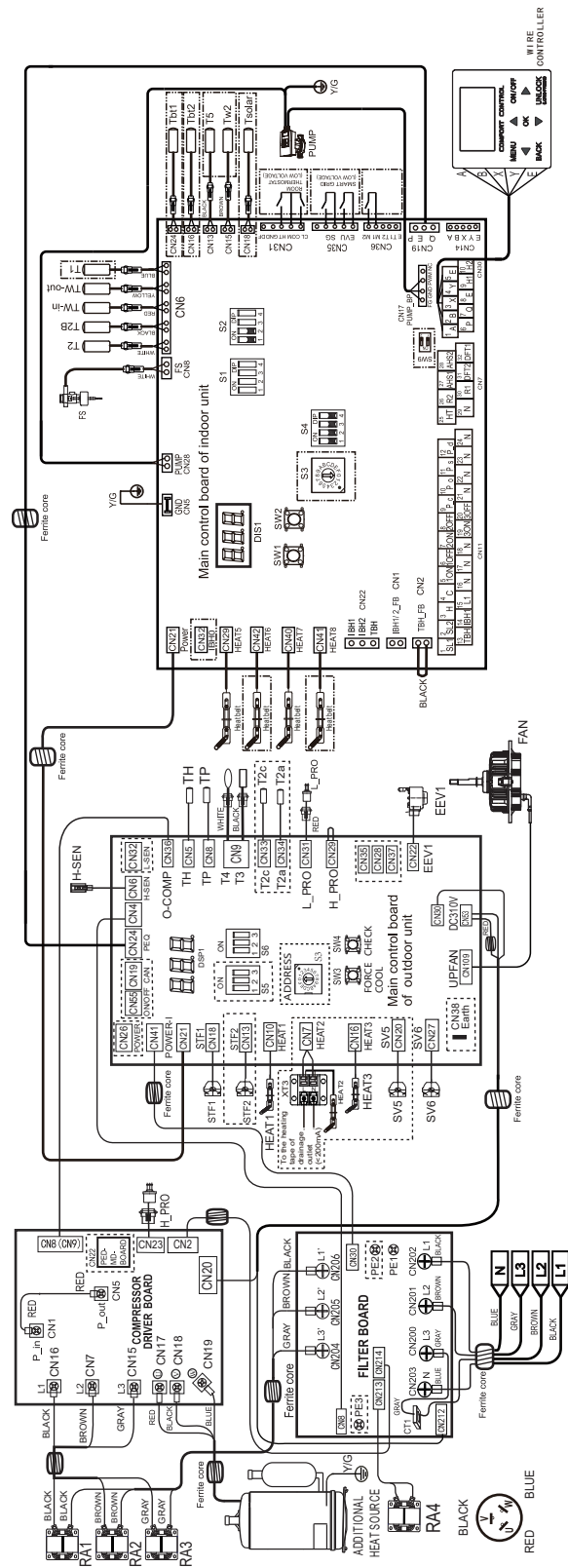

# Wiring diagram for units 18-30 kW

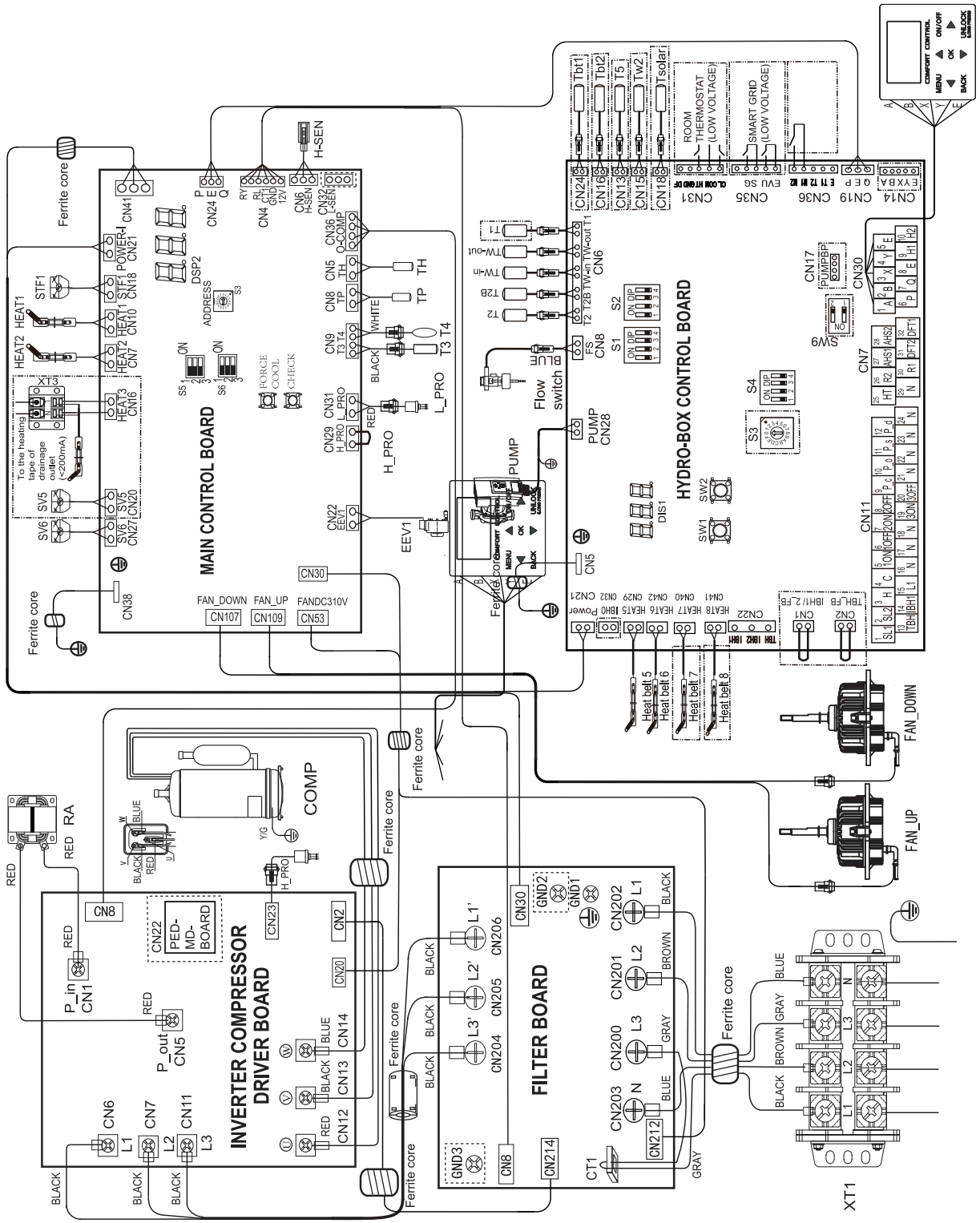

#### 9.4 WATER PIPES.

All the lengths and distances from the pipes have been taken into consideration.

##### Requirements

The maximum admissible length of the cable of the temperature probe is 20 m. This is the maximum admissible distance between the domestic hot water storage tank and the unit (only for installations with domestic hot water storage tank). The cable of the probe supplied with the domestic hot water storage tank is 10 m long. To enhance efficiency, it is recommended to install the 3-way valve and the domestic hot water storage tank as close to the unit as possible.

##### NOTE

If the system is supplied with a domestic hot water storage tank, see the use and maintenance manual of the domestic hot water storage tank. If there is no glycol (anti-freeze) in the system, there is a power or pump failure; empty the system (as shown in the figure below).

##### Models 4-16kW.

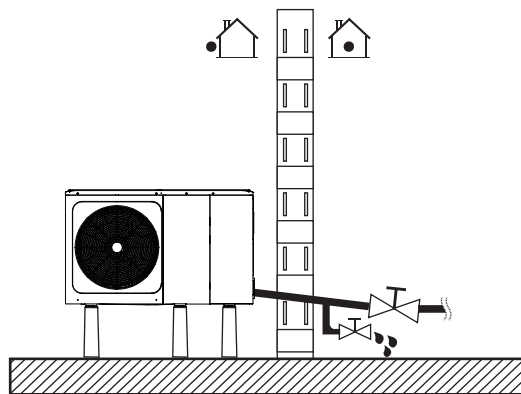

##### Models 18-30kW.

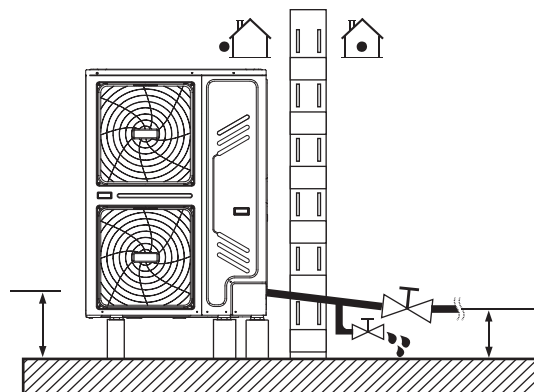

##### NOTE

If water is not removed from the system under frozen conditions with the unit idle, the frozen water could damage parts of the hydraulic circuit.

##### 9.4.1 Check the water circuit.

The units are fitted with a water inlet and outlet for connection to a water circuit.

The units must only be connected to closed water circuits. Connection to an open water circuit could cause excessive corrosion to the water pipes. Only materials compliant with current laws must be used.

Before going on with installation of the units, check the following:

- Maximum water pressure  $\leq 3$  bar.
- Maximum water temperature  $\leq 70^{\circ}\text{C}$  depending on the setting of the safety device.
- Always use materials that are compatible with the water used in the system and with the materials used in the unit.

- Make sure that the components installed in the on-field pipes can withstand the water temperature and pressure.
- The drain cocks must all be installed in the low points of the system to completely drain the circuit during maintenance.
- All the high points of the system must be fitted with vents. The vents must be located in easily accessible points to perform service operations. There is an automatic air purge valve inside the unit. Check that this air purge valve is not tight so that air may be automatically relieved from the water circuit.

#### 9.4.2 Water volume and dimensioning of the expansion vessels.

##### Models 4-16kW.

The units are equipped with an 8L expansion vessel with a default pre-pressure of 1.5 bar. The pre-pressure of the expansion vessel might need to be adjusted to guarantee proper operation of the unit.

1) Check that the total water volume of the system always available and not shut off, excluding the internal water volume of the unit, is at least 40L. See Chap. 14 “Technical specifications” to find the total internal water volume of the unit.

#### NOTE

- In the majority of applications, this minimum water volume will be satisfactory.
- However in critical processes or in environments with a high thermal load, additional water could be necessary.
- When the circulation in each space heating circuit is controlled by remote control valves, this minimum water volume needs to be maintained even if all the valves are closed.

2) The volume of the expansion vessel must be adjusted to the total volume of the water system.

3) Dimension the expansion for the heating and cooling circuit.

The volume of the expansion vessel can follow the figure below:

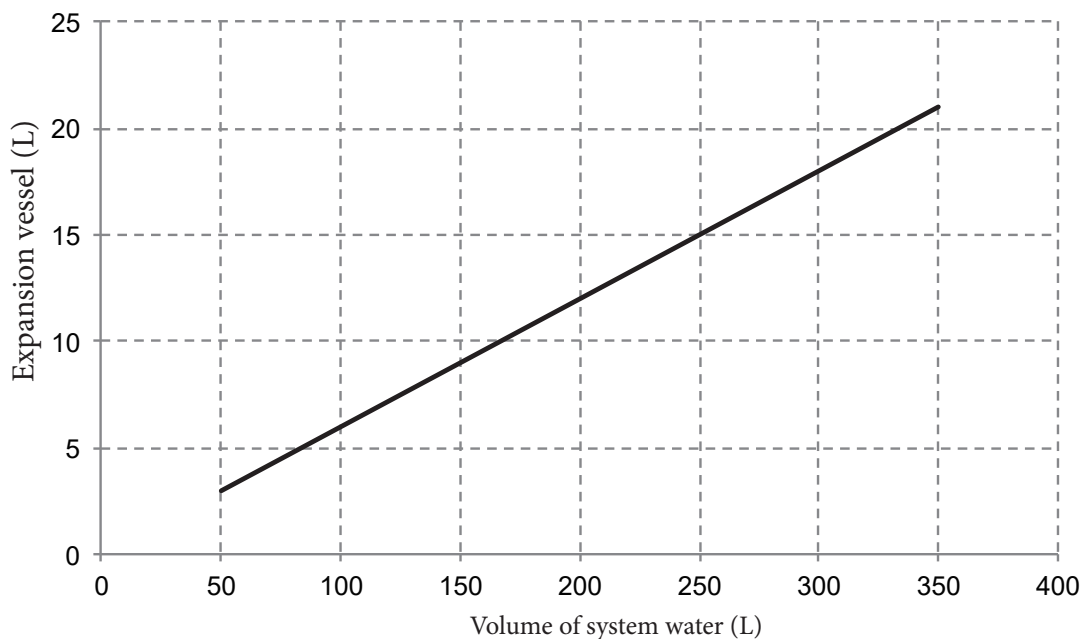

### Models 18-30kW.

The units are fitted with an 8L expansion vessel with a default pre-pressure of 1.0 bar. The pre-pressure of the expansion vessel might need to be adjusted to guarantee proper operation of the unit.

1) Check that the total water volume of the system always available and not shut off, excluding the internal water volume of the unit, is at least 40L. See Chap. 14 “Technical specifications” to find the total internal water volume of the unit.

#### NOTE

- In the majority of applications, this minimum water volume will be satisfactory.
- However in critical processes or in environments with a high thermal load, additional water could be necessary.
- When the circulation in each space heating circuit is controlled by remote control valves, this minimum water volume needs to be maintained even if all the valves are closed.

2) Using the table below, determine whether the pre-pressure of the expansion vessel needs to be adjusted.

3) Using the table and the instructions below, determine whether the total water volume of the system is less than the maximum admissible water volume.

Installation height difference (*)	Water volume ≤ 230L	Water volume > 230L
≤ 7 m	No pre-pressure adjustment is necessary	Required actions: <ul style="list-style-type: none"><li>• The pre-pressure must be increased, calculated according to: “Calculation of expansion vessel pre-pressure” (see below).</li><li>• Check whether the water volume is less than the maximum admissible volume (use the graph below).</li></ul>
> 7 m	Required actions: <ul style="list-style-type: none"><li>• The pre-pressure must be increased, calculated according to: “Calculation of expansion vessel pre-pressure” (see below).</li><li>• Check whether the water volume is less than the maximum admissible volume (use the chart below).</li></ul>	Expansion vessel of the unit too small for the system.

(\*): the height difference calculated between the highest point of the water circuit and the expansion tank of the heat pump. Unless the unit is located at the highest point of the system, in which case the installation height difference is considered zero.

#### Calculation of the expansion vessel pre-pressure.

The pre-pressure to be set depends on the maximum difference in the installation height (H) and is calculated as follows:  
 $P_g(\text{bar}) = (H(\text{m}) / 10 + 0.3) \text{bar}$

#### Calculation of the maximum admissible water volume.

To determine the maximum admissible water volume in the entire circuit, proceed as follows:

- Determine the calculated pre-pressure ( $P_g$ ) for the corresponding maximum water volume using the chart below.
- Check that the total water volume of the entire water circuit is less than this value. Otherwise the expansion vessel inside the unit is too small for the installation.

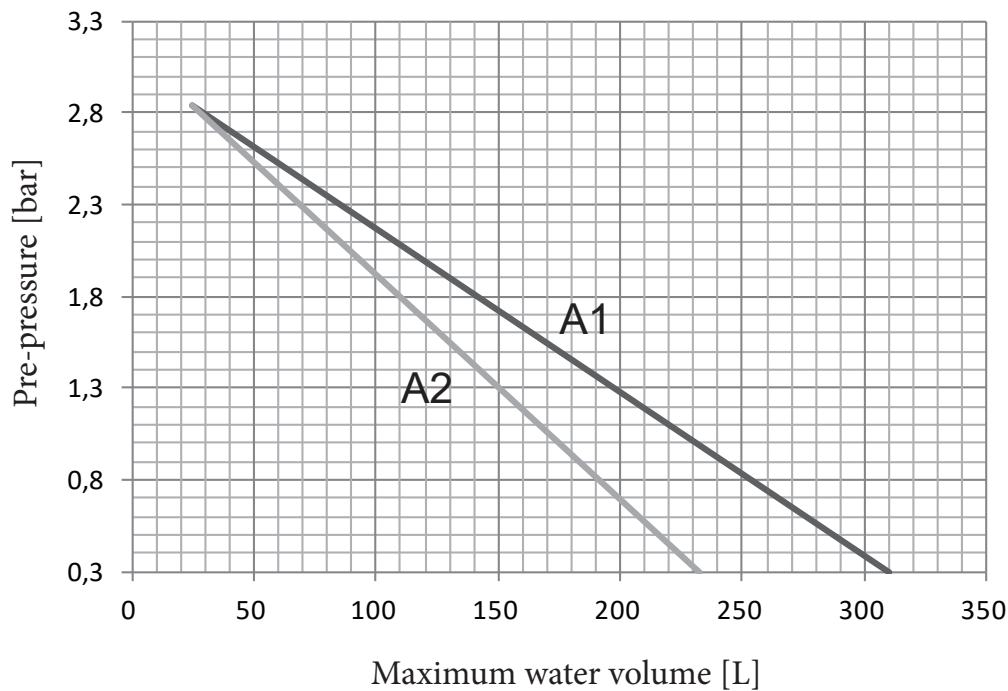

Pre-pressure = expansion vessel pre-pressure  
 Maximum water volume = maximum water volume in the system  
 A1 System without glycol  
 A2 System with 25% propylene glycol

#### Example 1

The unit is installed 5 m below the highest point of the water circuit. The total volume of the water in the water circuit is 100L. In this example, no action or adjustment is necessary.

#### Example 2

The unit is installed at the highest point of the water circuit. The total volume of the water in the water circuit is 250L.

Result:

- Since 250L are more than 230L, the pre-pressure must be decreased (see previous table).
- The required pre-pressure is  $P_g(\text{bar}) = (H(\text{m})/10 + 0.3)\text{bar} = (0/10 + 0.3)\text{bar} = 0.3\text{bar}$
- The corresponding maximum water value can be read from the chart: indicatively 310L.
- Since the total water volume (250L) is less than the maximum water volume (310L), the expansion vessel is sufficient for the installation.

#### Setting of the expansion vessel pre-pressure.

When the default pre-pressure of the expansion vessel (1.0 bar) needs to be modified, follow the guidelines:

- Use only dry nitrogen to adjust the pressure of the expansion vessel.
- An incorrect setting of the expansion vessel pre-pressure would cause the system to malfunction. Pre-pressure must only be adjusted by an authorised installer.

#### Selection of the additional expansion vessel.

If the expansion vessel of the appliance is too small for the installation, a further expansion vessel is necessary.

- Calculate the expansion vessel pre-pressure  $P_g(\text{bar}) = (H(\text{m})/10 + 0.3)\text{bar}$ . The expansion vessel in the unit should also adjust the pre-pressure.
- Calculate the necessary volume of the additional expansion vessel:

$$V1 = 0.0693 * V_{\text{water}} / (2.5 - P_g) - V0$$

$V_{\text{water}}$  is the water volume in the system,  $V0$  is the volume of the expansion vessel the unit is supplied with (L).



### 9.4.3 Water circuit connection.

The water connections must be performed properly according to the labels applied on the heat pump, indicating water inlet and outlet.

#### ⚠ CAUTION

Be careful not to deform the unit's pipes by exerting excessive force when connecting the pipes. Pipe deformations can cause the unit to malfunction.

Always keep the following in mind when connecting the water circuit:

- Use a proper thread sealant to seal the connections. The seal must be capable of withstanding the pressures and temperatures of the system.
- When non-copper metal pipes are used, make sure the two materials are insulated from each other to avoid galvanic corrosion.

Models 4-16kW.

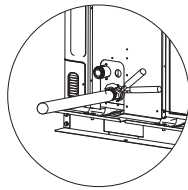

Models 18-30kW.

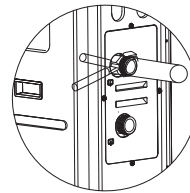

#### 💡 NOTE

The unit must be used in a closed water system only. The application in an open water circuit could cause excessive corrosion to the water pipes:

- Never use any galvanised parts in the water circuit. These parts can corrode excessively as the copper pipes are used in the internal water circuit of the unit
- When a 3-way valve or 2-way valve is used in the water circuit. The maximum recommended switching time of the valve should be less than 60 seconds.

### 9.4.4 Anti-freeze protection of water circuit.

All the internal hydronic parts are insulated to reduce thermal dispersion. Insulation must also be added to the pipes on the field.

The software has special functions that use the heat pump to protect the entire system from freezing. When the water flow temperature in the system drops below a certain value, the unit heats the water with the heat pump. The anti-freeze protection function only deactivates when the temperature rises to a certain value.

In case of a power failure, the above features would not protect the unit from freezing. It is therefore recommended to empty the system (if the water is not mixed with glycol). If the system remains idle, empty it and disassemble and clean the flow switch to prevent the water inside from freezing. The flow switch must be removed and dried, and then refitted in the unit.

Models 4-16kW.

“Anti-clockwise rotation, remove the flow switch. Dry the flow switch completely.”

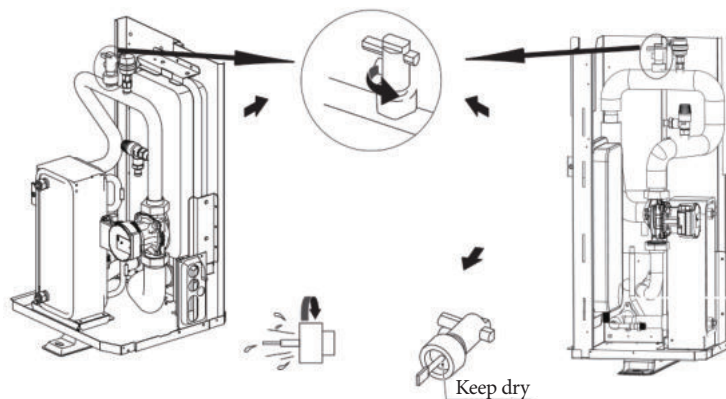

### Models 18-30kW.

“Anti-clockwise rotation, remove the flow switch. Dry the flow switch completely.”

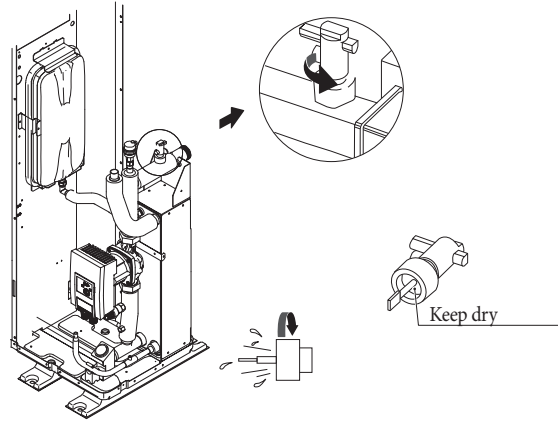

### **⚠ CAUTION**

When the unit remains idle for a long time, make sure it remains on. If you want to cut power, the water should be completely drained from the system to prevent the unit and pipes from being damaged by freezing. Furthermore, power must be cut from the unit after the system has been emptied.

### **⚠ WARNING**

Ethylene glycol and polypropylene glycol are TOXIC.

### 9.5 FILLING WITH WATER.

- Connect the water feed to the filling valve and open the valve.
- Make sure that the automatic air purge valve is open (at least 2 turns).
- Fill with water at a pressure of approximately 2.0 bar. Remove as much air in the circuit as possible by using the air purge valves.

### Models 4-16 kW

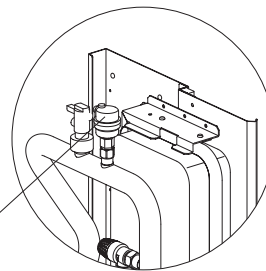

### Models 18-30 kW

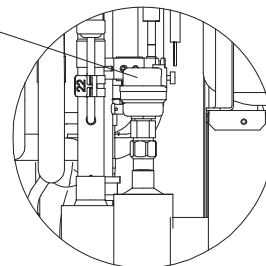

To deaerate the system, remove the black plastic cap (if present) and open the air purge valve, turn anti-clockwise at least 2 complete turns to release air from the system.  
When the de-aeration operation is over, put the black plastic cap back on, paying attention to position the vent valve near the slit in the cap.

## NOTE

It might not be possible to remove all the air in the system while filling. The remaining air will be removed by means of the automatic air purge valves during the initial hours of operation of the system. It could be necessary to top up water afterwards.

- The water pressure varies depending on the water temperature (the higher the temperature the higher the pressure). Nonetheless, water pressure must always remain below 0.3 bar to prevent air from entering the circuit.
- The unit might discharge too much water through the safety valve.
- The quality of the water must comply with directives EN 98/83 EC.
- Details on the water quality conditions are found in directives EN 98/83 EC.

### 9.6 WATER PIPE INSULATION.

The entire water circuit, including all of water pipes, must be insulated to prevent condensate from forming in cooling mode and the reduction of heating and cooling capacity, as well as to prevent the outside water pipes from freezing during winter. The insulation material must have a fire resistance of at least B1 and must comply with all standards in force. The sealing materials must be at least 13 mm thick with thermal conductivity 0.039 W/mK to prevent outside water pipes from freezing.

If the outdoor temperature is above 30° C and 80% RH respectively, the thickness of the sealing materials shall be at least 20 mm to prevent any condensate build-up on the gasket surface.

### 9.7 WIRING ON FIELD.

## WARNING

A main switch or another disconnection device, with separation of contacts in all poles, must be incorporated in the fixed wiring in compliance with local laws and standards. Switch of power before performing any connection. Only use copper cables. Never clamp the cables in bundles and make sure they do not come into contact with pipes and sharp corners. Make sure no external pressure is applied to the connections of the terminals. All the cables and components on the field must be installed by an authorised electrician and must comply with local laws and standards.

On-field wiring must be carried out according to the wiring diagram supplied with the unit and in compliance with the following instructions.

Make sure to use a dedicated power supply. Never use a power supply shared by another device.

Check that there is an earthing connection. Do not earth the unit to a service pipe, to a surge protective device or to earthing of the telephone line. Incomplete earthing can cause electric shocks.

Make sure to install a ground fault circuit interrupter (30 mA). Otherwise electrical shocks could occur.

Make sure to install the required fuses or circuit breakers.

#### 9.7.1 Precautions for wiring jobs.

- Secure the cables so that they do not come into contact with the pipes (especially on the high-pressure side).
- Secure the wiring with cable clamps to prevent them from coming into contact with the pipes, especially on the high-pressure side.
- Make sure no external pressure is applied to the connectors of the terminals.
- When the ground fault circuit interrupter is installed, make sure that it is compatible with the inverter (resistant to high-frequency electric disturbances) to avoid needless opening of the round fault circuit interrupter.

## NOTE

The earth leakage circuit breaker must be a high-speed switch of 30 mA (<0.1 s).

- This unit is fitted with an inverter. The installation of a shunt capacitor not only reduces the improvement effect of the power factor, but can all also cause anomalous heating of the capacitor due to high-frequency waves. Never install a shunt capacitor as it could cause accidents.

### 9.7.2 Wiring overview.

#### Models 4-16kW.

The illustration below provides an overview of the field wiring required between the different parts of the system.

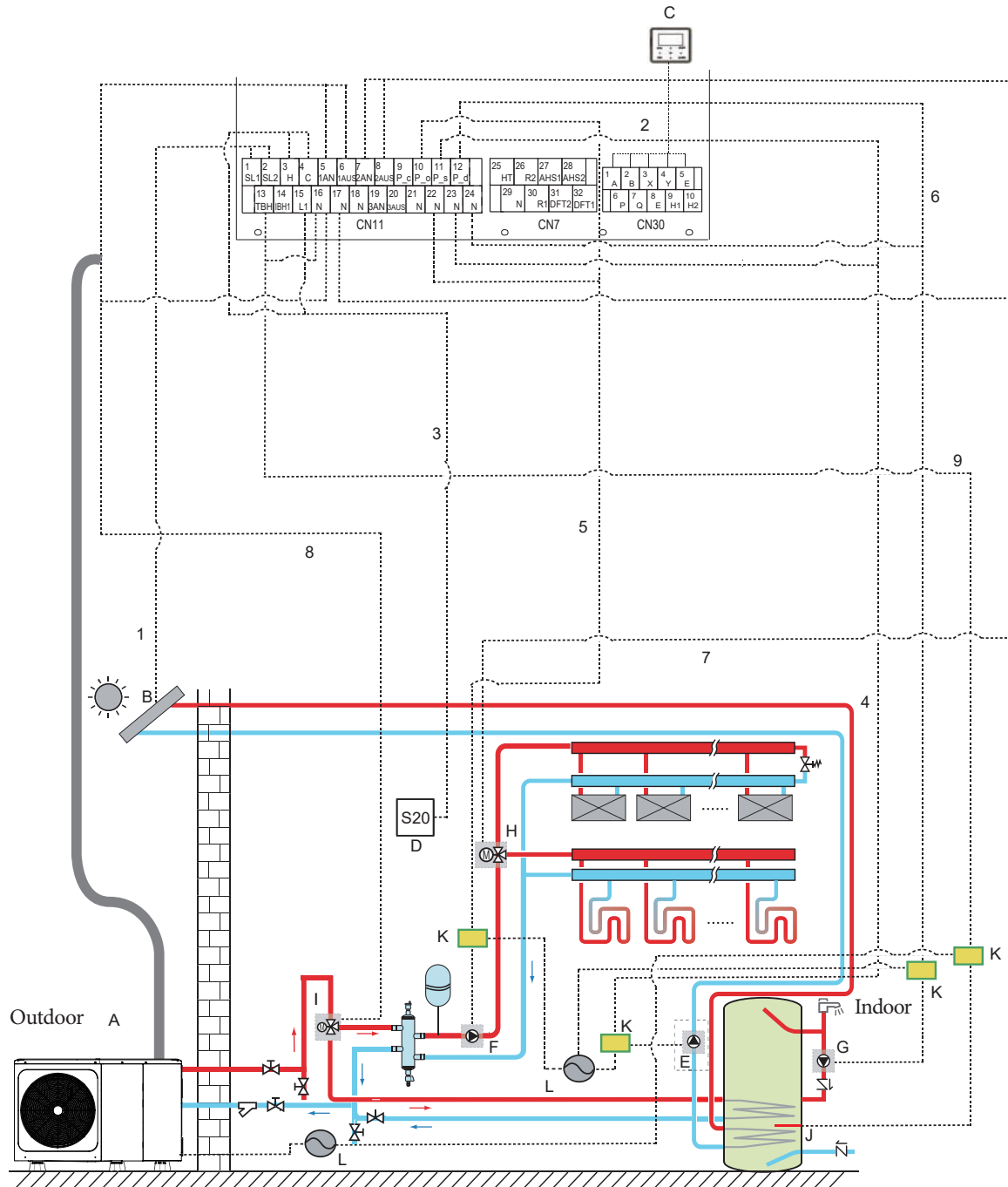

Code	Assembly unit	Code	Assembly unit
A	Heat pump	G	P_d: DHW pump
B	Solar energy kit	H	SV2: 3-way valve
C	Control panel	I	SV1: 3-way valve for domestic hot water tank
D	High-voltage room thermostat	J	TBH: Heater of DHW storage tank
E	P_s: solar pump	K	Contactors
F	P_o: external circulation pump	L	Electric power supply

Element	Description	AC/DC	Number of conductors required	Maximum operating current
1	Signal cable of the solar energy kit	AC	2	200 mA
2	Control panel cable	AC	5	200 mA
3	Room thermostat cable	AC	2	200 mA (a)
4	Solar pump control cable	AC	2	200 mA (a)
5	External circulation pump control cable	AC	2	200 mA (a)
6	Domestic hot water pump control cable	AC	2	200 mA (a)
7	SV2: 3-way valve control cable	AC	3	200 mA (a)
8	SV1: 3-way valve control cable	AC	3	200 mA (a)
9	Booster heater control cable	AC	2	200 mA (a)

(a): Minimum cable cross-section AWG18 (0.75 mm<sup>2</sup>)

### NOTE

Please use H07RN-F for the power cable. All the cables are connected in high-voltage except for the probe cable and the control panel cable.

- The instruments must be earthed.
- All external high-voltage loads, if in metal or with earthing connection, must be earthed.
- All external load currents must be lower than 0.2A, if the single load current is higher than 0.2A, the load must be controlled by an AC contactor.
- The ports of the wiring terminals R1, R2, and DFT1, DFT2 only supply a signal switch. Please refer to Chap. 9.7.6 To obtain the position of the ports in the unit.

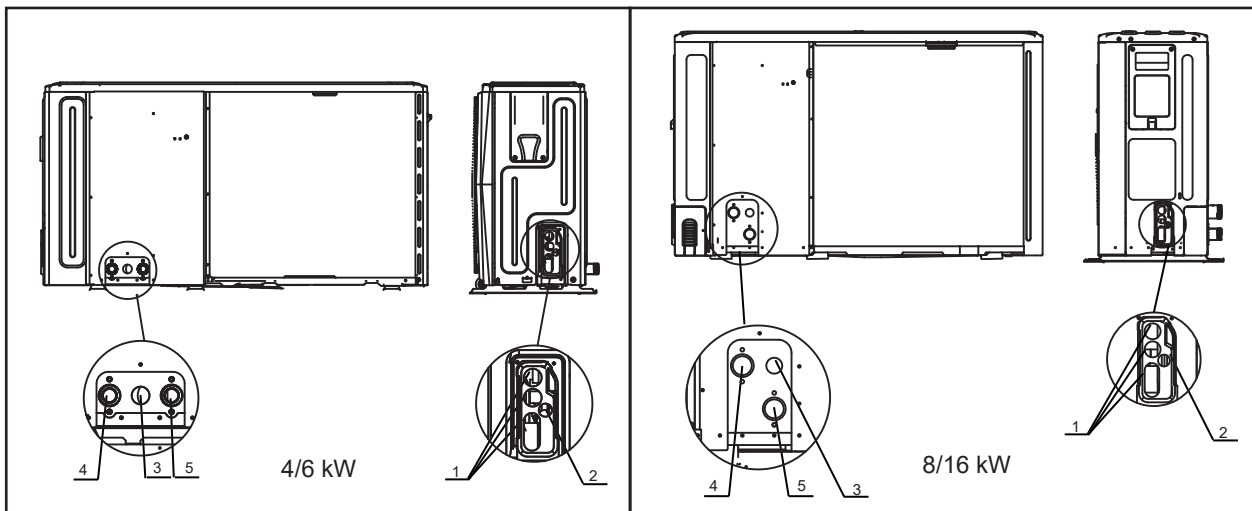

Code	Assembly unit
1	Hole for high-voltage cable
2	Hole for low-voltage cable
3	Drain pipe hole
4	Water outlet
5	Water inlet

**Guidelines for field wiring.**

**⚠ CAUTION**

Switch off power before removing the service panel of the electric switchgear.

- Secure all the cables with clamps.
- Systems equipped with a domestic hot water tank require a dedicated power supply circuit for the storage tank heater. Refer to the Use and installation manual of the domestic hot water storage tank. Fasten the wires in the order indicated below.
- Arrange the electric wiring so that the front cover does not lift up during wiring operations and firmly fix the front cover.
- Follow the wiring diagram for the electric wiring jobs (the wiring diagrams are located on the back of the door: no.1 for units 4-6kW and no.2 for units 8-16kW).
- Install the cables and firmly secure the cover so that it can be inserted properly.

**Models 18-30kW.**

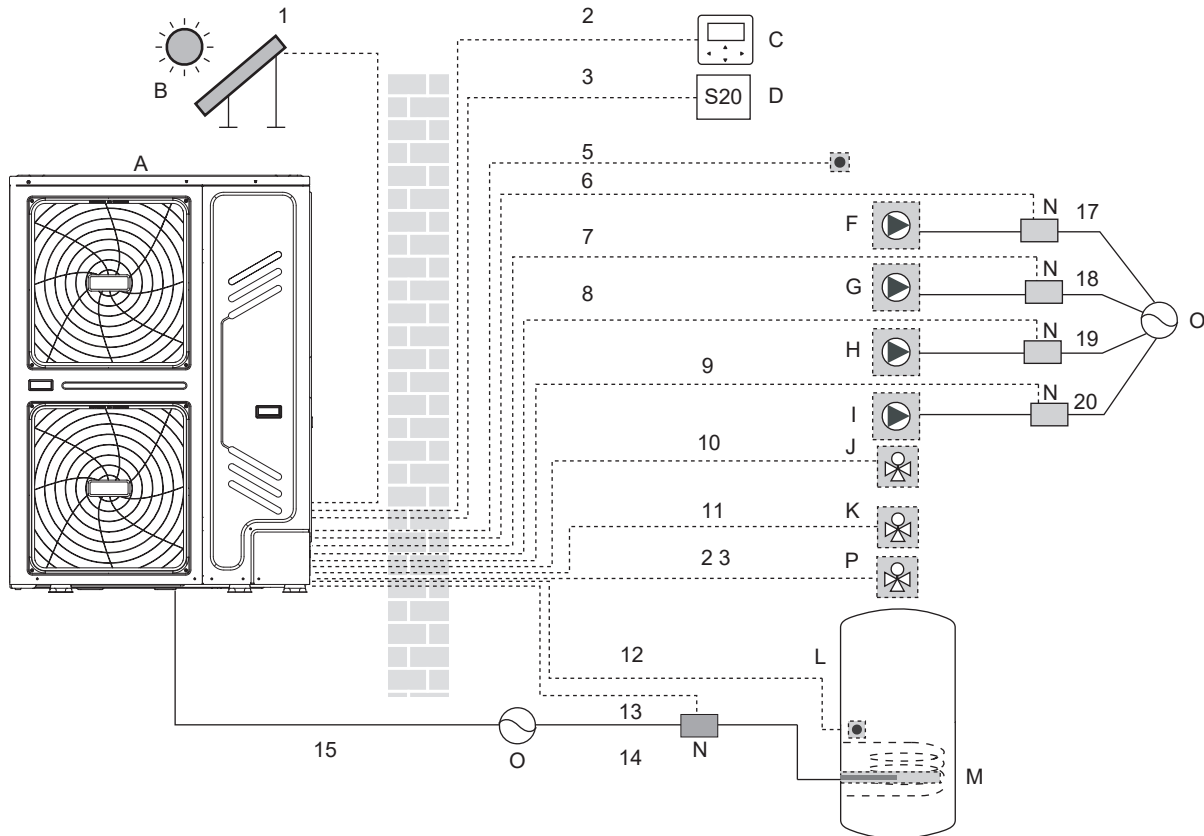

Code	Assembly unit	Code	Assembly unit
A	Heat pump	J	SV2: 3-way valve
B	Solar energy kit	K	SV1: 3-way valve for domestic hot water storage tank
C	Control panel	L	Domestic hot water tank
D	Room thermostat	M	Booster heater
F	P_s: solar pump	N	Contacteur
G	P_c: circulation pump / zone 2 pump	O	Power supply
H	P_o: external circulation pump / zone 1 pump	P	Zone 2 SV3 (3-way valve)
I	P_d: DHW pump		

Element	Description	AC/DC	Number of conductors required	Maximum operating current
1	Signal cable of the solar energy kit	AC	2	200 mA
2	Control panel cable	AC	5	200 mA
3	Room thermostat cable	AC	2 or 3	200 mA (a)
5	Probe cable for Tw2	DC	2	(b)
9	Domestic hot water pump control cable	AC	2	200 mA (a)
10/11/23	3-way valve control cable	AC	2 or 3	200 mA (a)
12	Probe cable for T5	DC	2	(b)
13	Booster heater control cable	AC	2	200 mA (a)
15	Unit power cable	AC	3+GND	(c)

(a): Minimum cable cross-section AWG18 (0.75 mm<sup>2</sup>)

(b): The thermistor and the connection cable (10 m) are delivered with the domestic hot water tank (T5) or with the zone 2 outlet temperature probe (Tw2).

(c): Chap. 9.7.4 Specifications of standard wiring components.

### NOTE

Please use H07RN-F for the power cable. All the cables are connected in high-voltage except for the thermistor cable and the user interface cable.

- The instruments must be earthed.
- All external high-voltage loads, if in metal or with earthing connection, must be earthed.
- All external load currents must be lower than 0.2A, if the single load current is higher than 0.2A, the load must be controlled by an AC contactor.
- The ports of the wiring terminals R1, R2, and DFT1, DFT2 only supply a signal switch. Please refer to Chap. 9.7.6 To obtain the position of the ports in the unit.

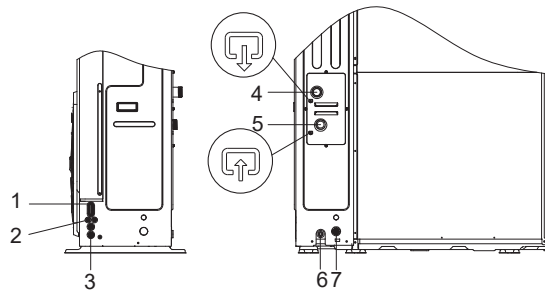

Code	Assembly unit
1	Hole for high-voltage wire
2	Hole for low-voltage wire
3	Hole for high-voltage or low-voltage cable
4	Water outlet
5	Water inlet
6	Drain outlet
7	Drain pipe hole (for safety valve)

### 9.7.3 Precautions for electric power wiring.

When connecting the power terminal, use the ring cable lug with insulation enclosure (See Figure 9.1).

Use a power cable compliant with specifications and firmly connect the power cable. Make sure the cable is firmly secured so that it is not yanked off by an outside force.

If it is not possible to use the ring cable lug with insulation enclosure, make sure:

- Not to connect two power cables with different diameters to the same power terminal (causing the wires to overheat due to loose wiring) (See figure 9.2).

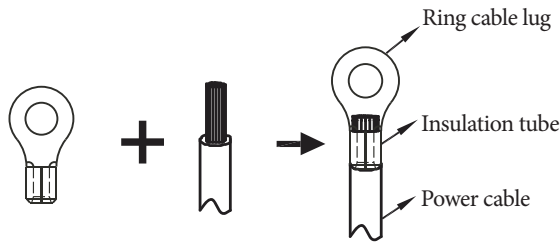

Figure 9.1

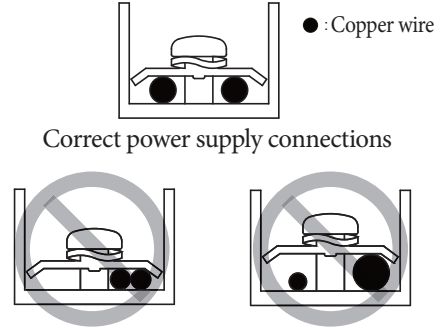

Figure 9.2

- Use the correct screwdriver to tighten the terminal screws. Small screwdrivers could damage the screw head and prevent them from being properly tightened.
- Overtightening the terminal screws could damage them.
- Connect an earth leakage circuit breaker and a fuse to the power line.
- In the wiring, make sure that the required wires are used, perform the complete connections and secure the wires so that no external force can affect the terminals.

### 9.7.4 Safety device requirements.

1. Select the cable diameters (minimum value) individually for each unit based on the table. If the rated current exceeds 63A, the diameters of the wires must be selected based on national regulations on wiring.
2. The maximum admissible variation of the phase to phase voltage range is 2%.
3. Select the circuit breaker with separation of contacts in all poles no lower than 3 mm to allow complete disconnection.

Rated current of the appliance (A)	Rated cross section area (mm <sup>2</sup> )	
	Flexible cables	Cable for fixed wiring
≤3	0.5 and 0.75	1 and 2.5
>3 and ≤6	0.75 and 1	1 and 2.5
>6 and ≤10	1 and 1.5	1 and 2.5
>10 and ≤16	1.5 and 2.5	1.5 and 4
>16 and ≤25	2.5 and 4	2.5 and 6
>25 and ≤32	4 and 6	4 and 10
>32 and ≤50	6 and 10	6 and 16
>50 and ≤63	10 and 16	10 and 25



9.7.5 Remove the cover of the main compartment.

Unit	4 kW	6 kW	8 kW	12 kW	14 kW	16 kW	12 kW T	14 kW T	16 kW T
Maximum overcurrent protection (MOP)	18	18	19	30	30	30	14	14	14
Cable dimension (mm <sup>2</sup> )	4.0	4.0	4.0	6.0	6.0	6.0	2.5	2.5	2.5

Unit	18 kW	22 kW	26 kW	30 kW
Maximum overcurrent protection (MOP)	18	21	24	28
Cable dimension (mm <sup>2</sup> )	6	6	6	6

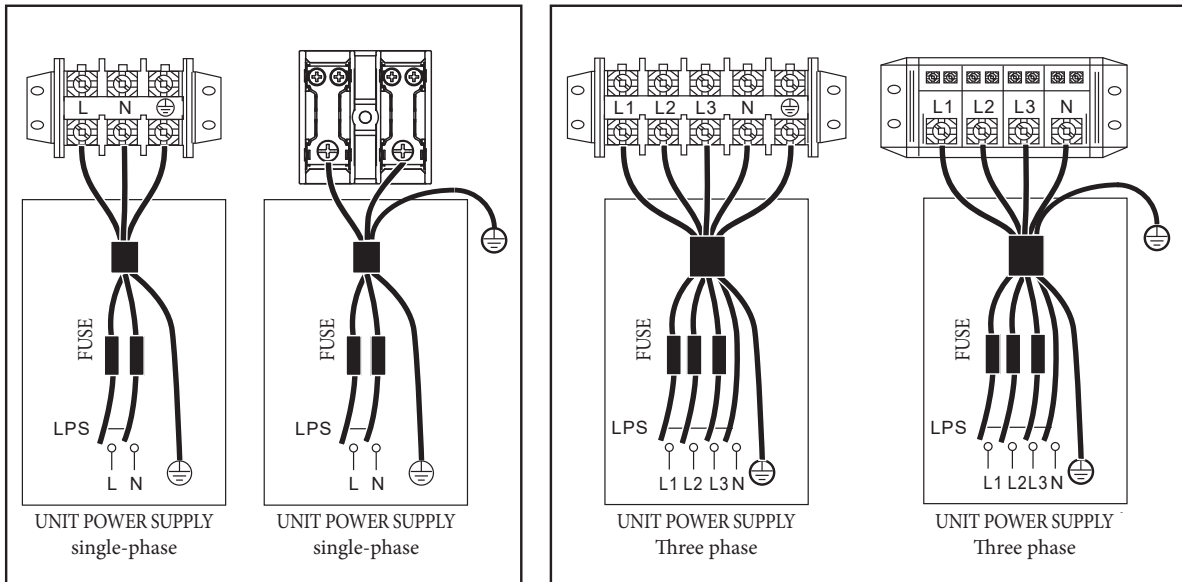

**NOTE**

The earth leakage circuit breaker must be high-speed type A - 30 mA (<0.1 s).  
The declared values are the maximum values (cf. electrical data for the exact values).

Connection of power cable of the cascade system.

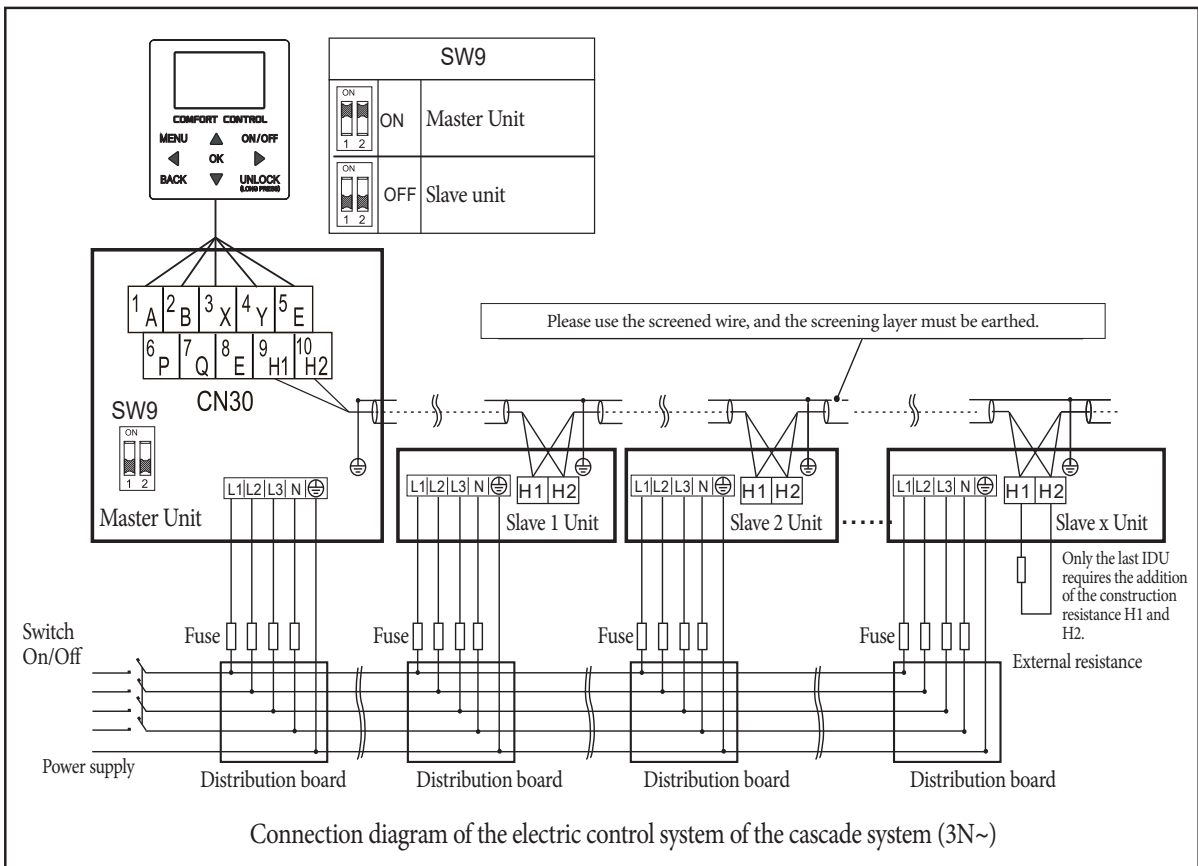
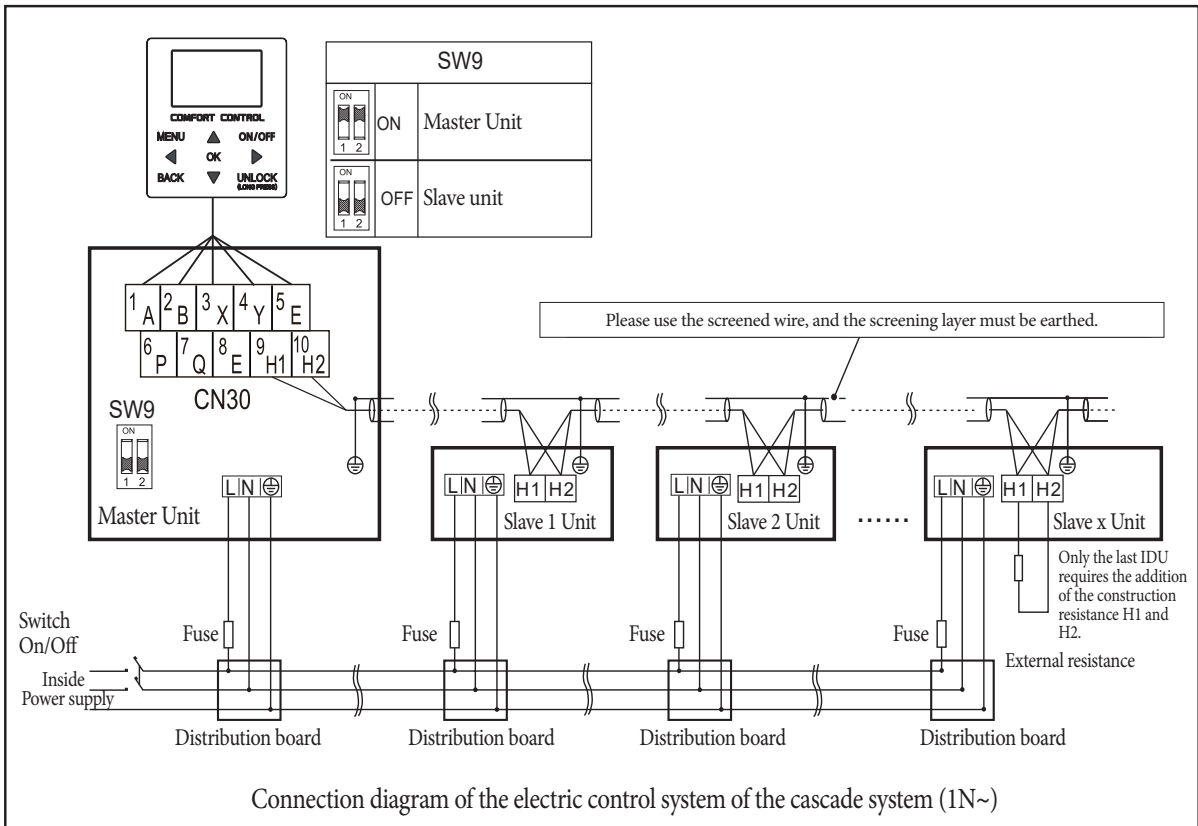

## ⚠ CAUTION

1. The cascade function of the system supports up to 6 machines.
2. To guarantee the success of automatic addressing, other the machines must be connected to the same power supply and powered evenly.
3. Only the Master unit can be connected to the control panel. SW9 of the Master unit must be switched “on”. The slave unit cannot be connected to the control panel.
4. Please use the screened cable, and the screening must be earthed.

### 9.7.6 Connection for other components.

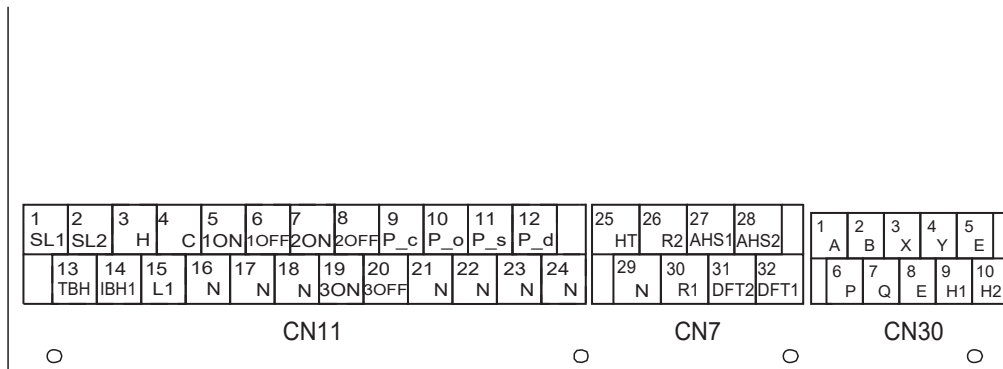

	Code	Print	Connection to	
CN11	①	1	SL1	Active solar station contact
		2	SL2	
	②	3	H	Room Thermostat Input (High voltage)
		4	C	
		15	L1	
	③	5	1ON	SV1 (3-way valve)
		6	1OFF	
		16	N	
	④	7	2ON	SV2 (3-way valve)
		8	2OFF	
		17	N	
⑤	9	P_c	Pump c Zone 2 circulator	
	21	N		
⑥	10	P_o	Pump o Zone 1 circulator	
	22	N		
⑦	11	P_s	Pump s Solar Circuit Circulator	
	23	N		
⑧	12	P_d	Pump d DHW recirculation pump	
	24	N		
⑨	13	TBH	Tank booster heater	
	16	N		
⑩	14	IBH1	Integrative electric resistance (optional)	
	17	N		
⑪	18	N	SV3 (3-way valve)	
	19	3ON		
	20	3OFF		

	Code	Print	Connection to	
CN30	①	1	A	Control panel
		2	B	
		3	X	
		4	Y	
	5	E		
③	9	H1	System in parallel	
	10	H2		

	Code	Print	Connection to	
CN7	①	26	R2	Compressor operation
		30	R1	
		31	DFT2	Alarm signal
	32	DFT1		
③	27	AHS1	Not used	
	28	AHS2		

The board of the main hydraulic module supplies two types of control signal ports:

**Type 1:** Potential-free contact.

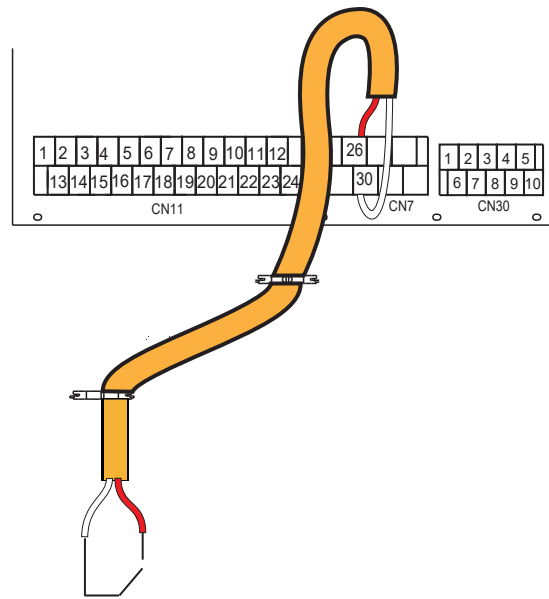

**Type 1** Running

**Type 2:** The port supplies the signal with 220V voltage.

If the load current is  $<0.2A$ , the load can be connected directly to the port.

If the load current is  $\geq 0.2A$ , an AC contactor must be connected for the load.

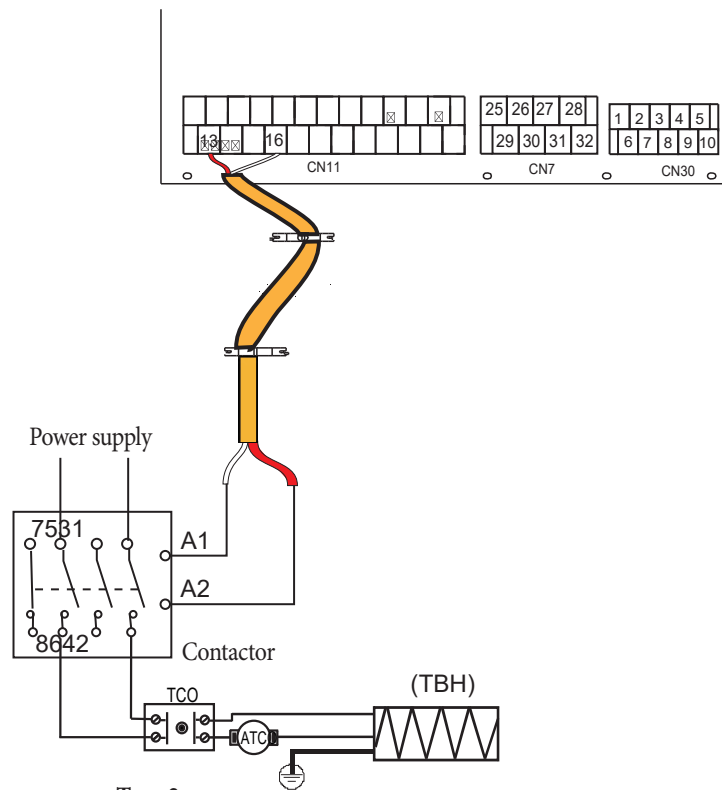

**Type 2**

The connectors CN11/CN7 of the board of the main hydraulic module: the active solar station contact, the 3-way valves, the pumps, the tank booster heater, etc.

# Horizontal terminal boards connections diagram

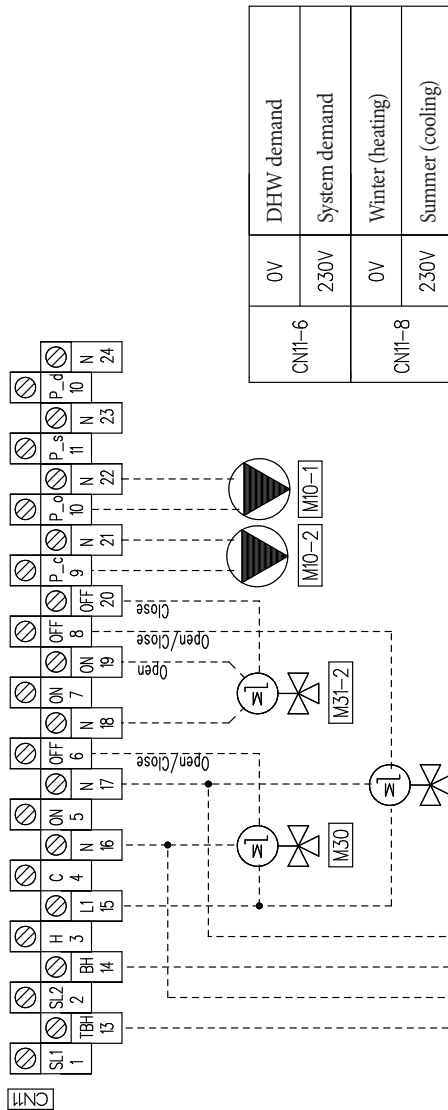
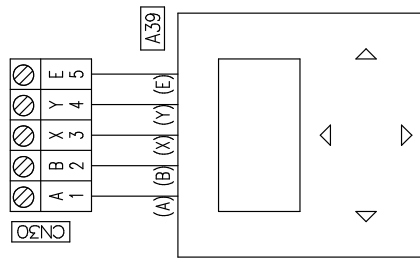

CN11-6	0V	DHW demand
	230V	System demand
CN11-8	0V	Winter (heating)
	230V	Summer (cooling)

Key:

- A39 - Control panel
- E15 - Domestic hot water integration resistance
- E16 - System integration resistance
- K15 - DHW integrative resistance relay
- K16 - System integrative resistance relay
- M10-1 - Zone 1 circulator pump
- M10-2 - Zone 2 circulator pump
- M30 - DHW/system 3-way valve
- M31-2 - Zone 2 mixing valve
- M52 - Summer/winter switch

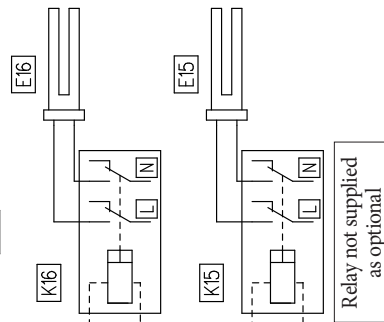
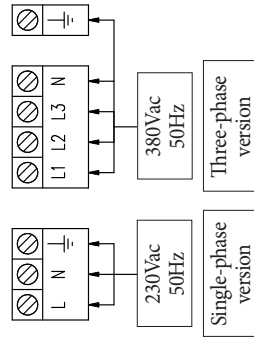

Relay not supplied as optional

## Vertical terminal boards connections diagram

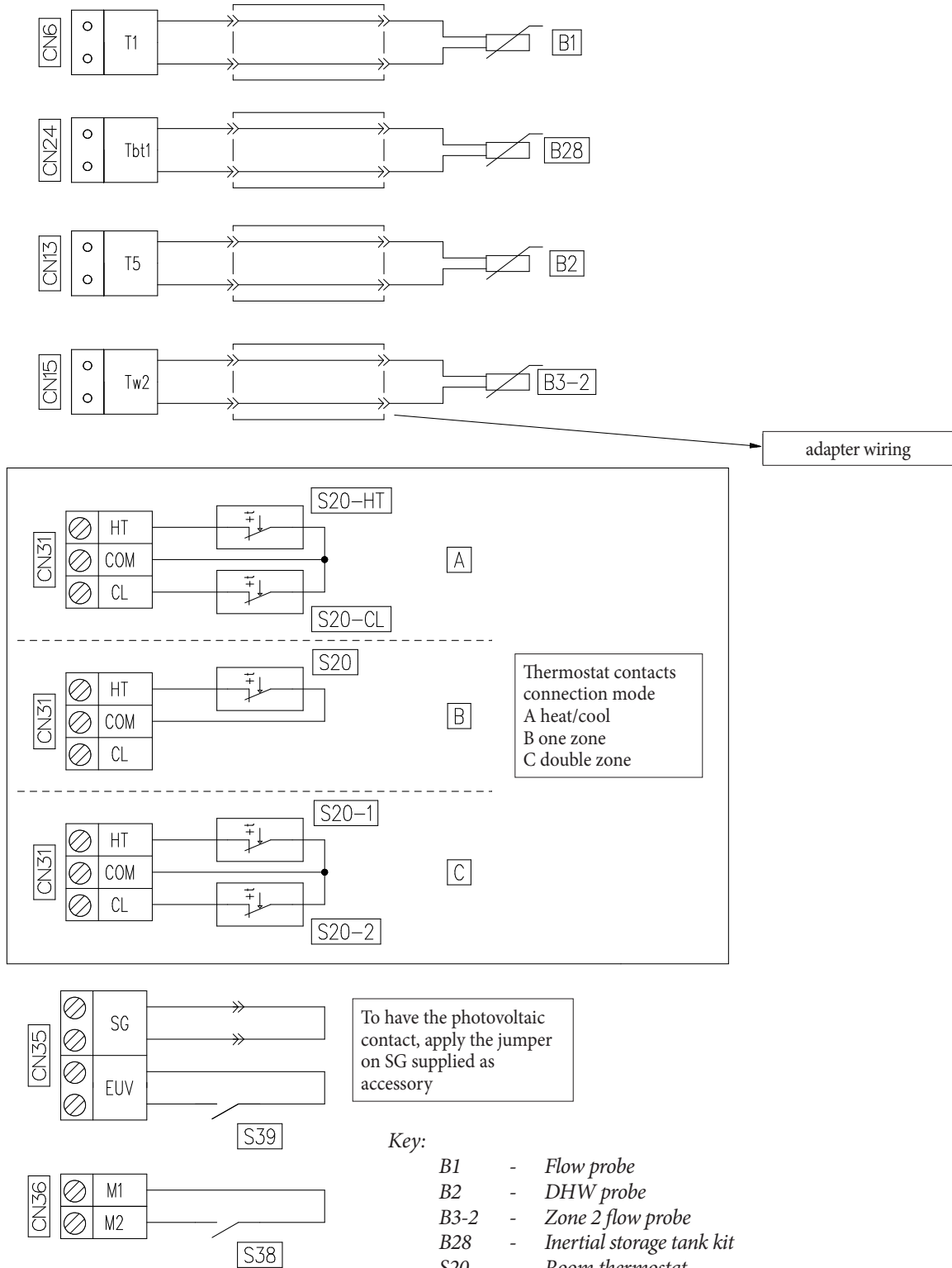

The wiring of the components is illustrated below.

- Connect the cable to the appropriate terminals as shown in the figure.
- Secure the cable firmly.

**1) For active solar station contact:**

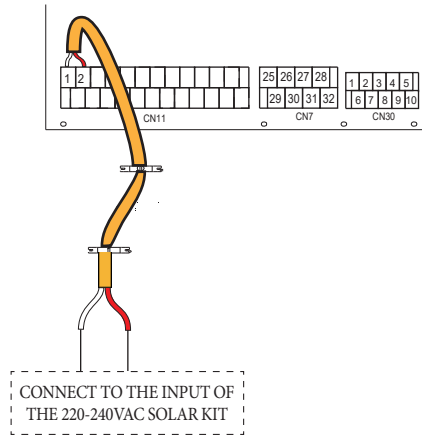

Voltage	220-240VAC
Maximum operating current (A)	0.2
Wiring size (mm <sup>2</sup> )	0.75

2) For the 3-way valves SV1, SV2 and SV3:

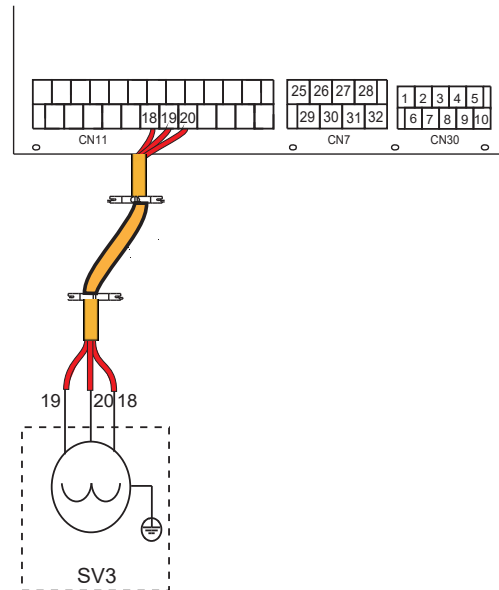
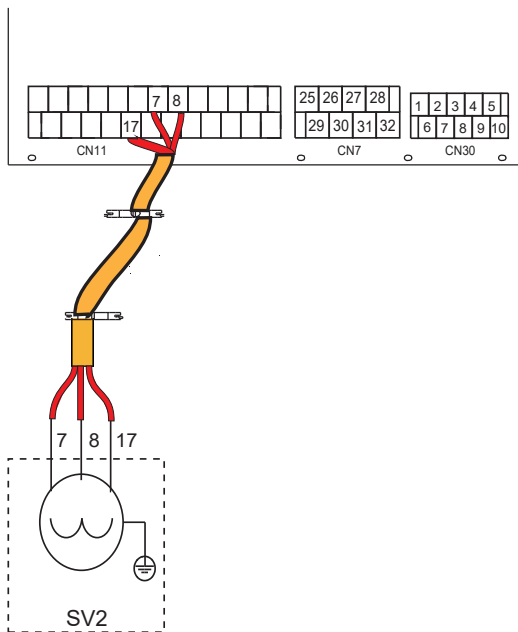
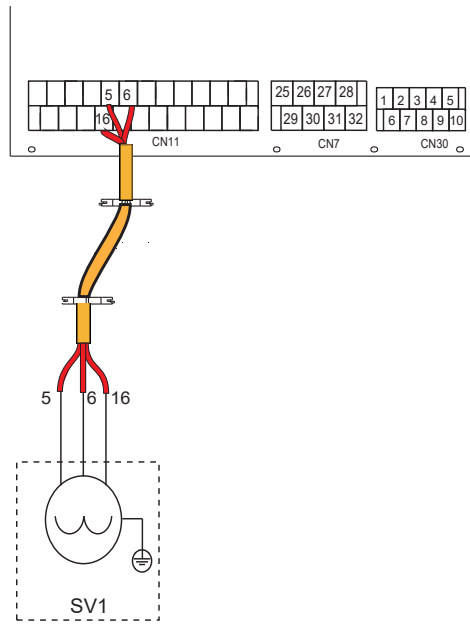

Voltage	220-240VAC
Maximum operating current (A)	0.2
Wiring size (mm <sup>2</sup> )	0.75
Type of signal of control port	Type 2



3) For remote switch off:

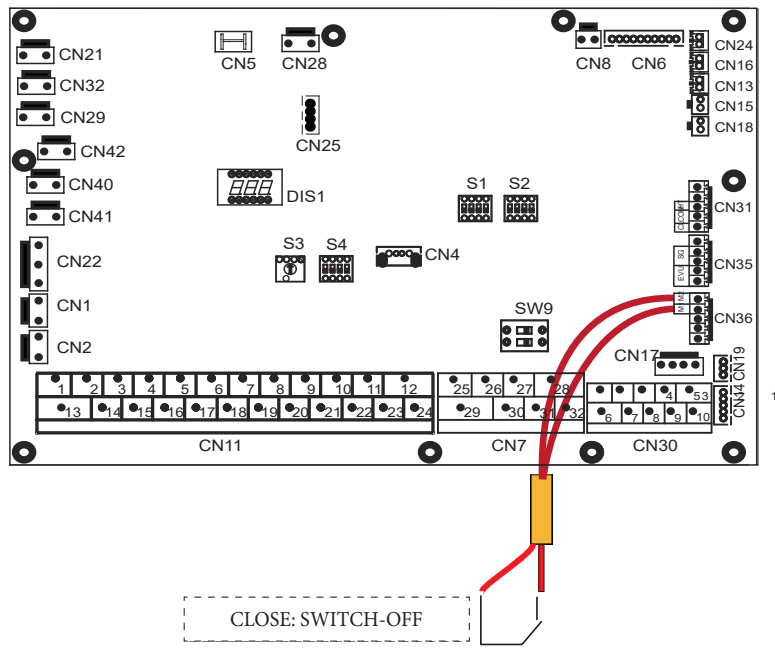

4) For DHW circulation pump:

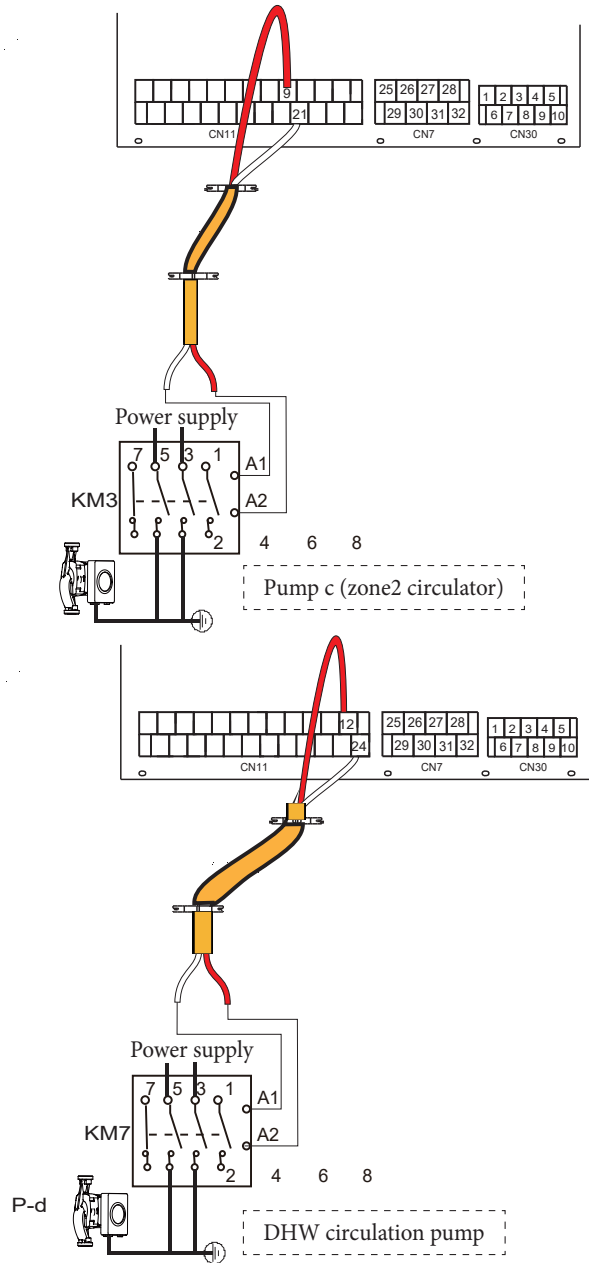

Voltage	220-240VAC
Maximum operating current (A)	0.2
Wiring size (mm <sup>2</sup> )	0.75
Type of signal of control port	Type 2

**5) For room thermostat:**

Room thermostat type 1 (High-voltage): "POWER SUPPLY INPUT" supplies the operating voltage to RT, does not directly supply voltage to the RT connector. The port "15 L1" supplies 220V voltage to the RT connector.

Room thermostat type 2 (Low-voltage): "POWER SUPPLY INPUT" supplies the working voltage to RT.

**NOTE**  
There are two optional connection methods that depend on the type of room thermostat.

**Room thermostat type 1 (High-voltage):**

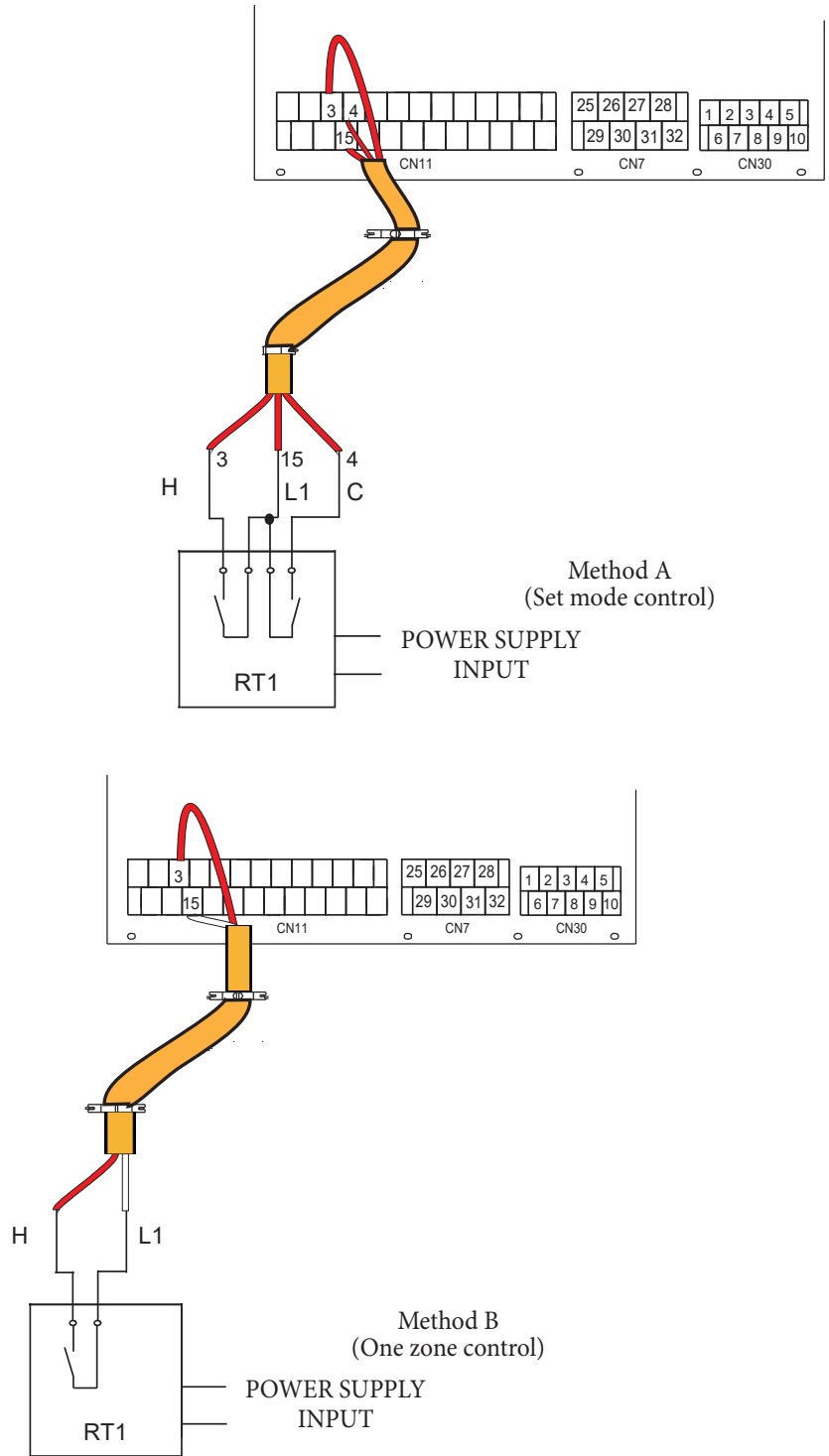

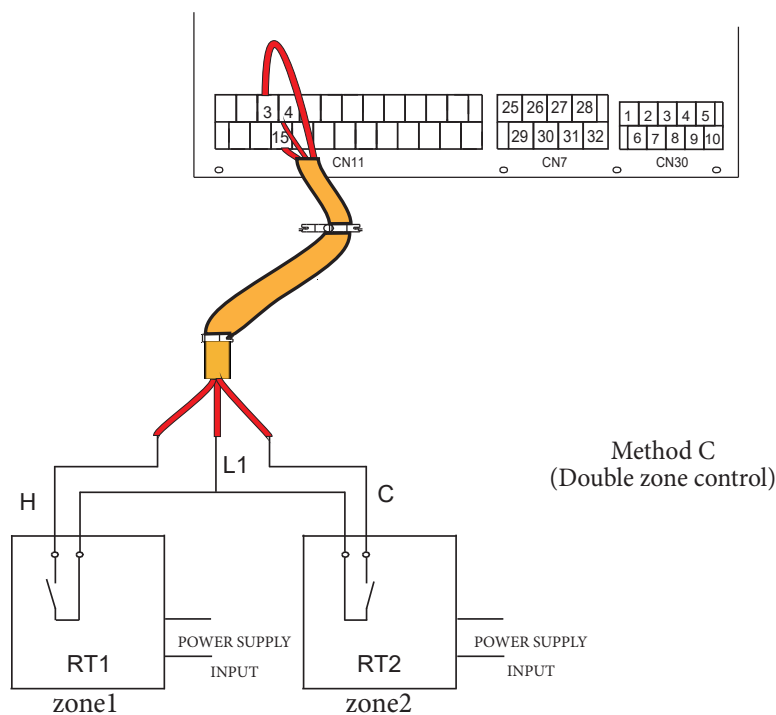

Voltage	220-240VAC
Maximum operating current (A)	0.2
Wiring size (mm <sup>2</sup> )	0.75

There are three methods to connect the thermostat cable (as described in the previous images) and it depends on the application.

- **METHOD A (Set mode control).**

RT can control heating and cooling individually, like the control panel for 4-pipe FCU. When the hydraulic module is connected with the external temperature controller, on the control panel, in the FOR SERVICEMAN menu, set ROOM THERMOSTAT at MODE SETTING:

A.1 When the unit detects a 230VAC voltage between C and L1, the unit runs in cooling mode.

A.2 When the unit detects a 230VAC voltage between H and L1, the unit runs in heating mode.

A.3 When the unit detects a 0VAC voltage for both sides (C-L1, H-L1), the unit stops operating for space heating or cooling.

A.4 When the unit detects a 230VAC voltage for both sides (C-L1, H-L1), the unit runs in cooling mode.

- **METHOD B (One zone control).**

RT supplies the switching signal to the unit. On the control panel, in the FOR SERVICEMAN menu, set ROOM THERMOSTAT at ONE ZONE:

B.1 When the unit detects a 230VAC voltage between H and L1, the unit switches on.

B.2 When the unit detects a 0VAC voltage between H and L1, the unit switches off.

- **METHOD C (Double zone control).**

The hydraulic module is connected with two room thermostats, on the control panel, in the FOR SERVICEMAN menu, set ROOM THERMOSTAT at DOUBLE ZONE:

C.1 When the unit detects a 230VAC voltage between H and L1, zone 1 switches on. When the unit detects a 0VAC voltage between H and L1, zone 1 switches off.

C.2 When the unit detects a 230VAC voltage between C and L1, zone 2 switches on depending on the weather temperature curves. When the unit detects a 0VAC voltage between C and L1, zone 2 switches off.

C.3 When H-L1 and C-L1 are detected as 0VAC, the unit switches off.

C.4 When H-L1 and C-L1 are detected as 230VAC, both zone 1 and zone 2 switch on.

Room thermostat type 2 (Low-Voltage):

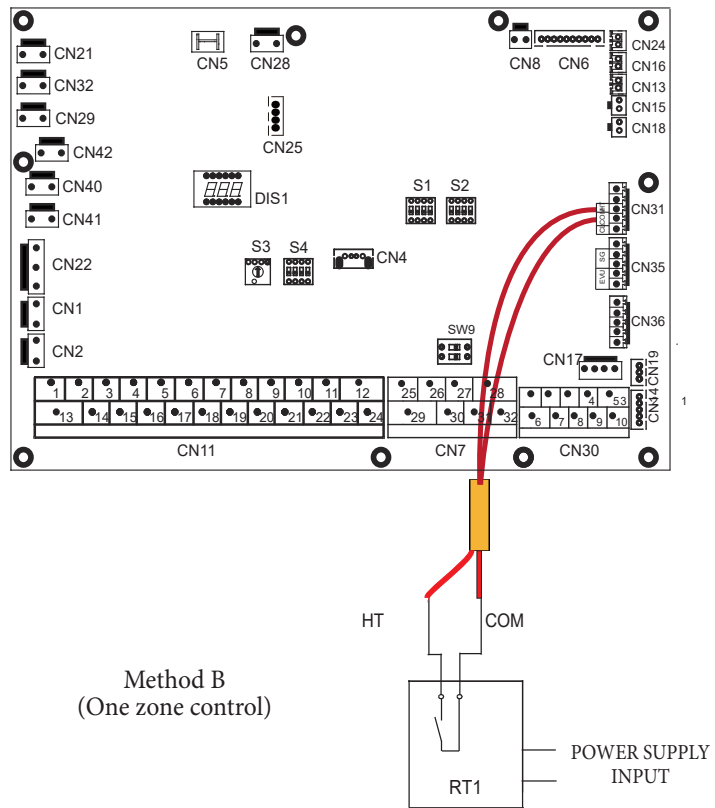
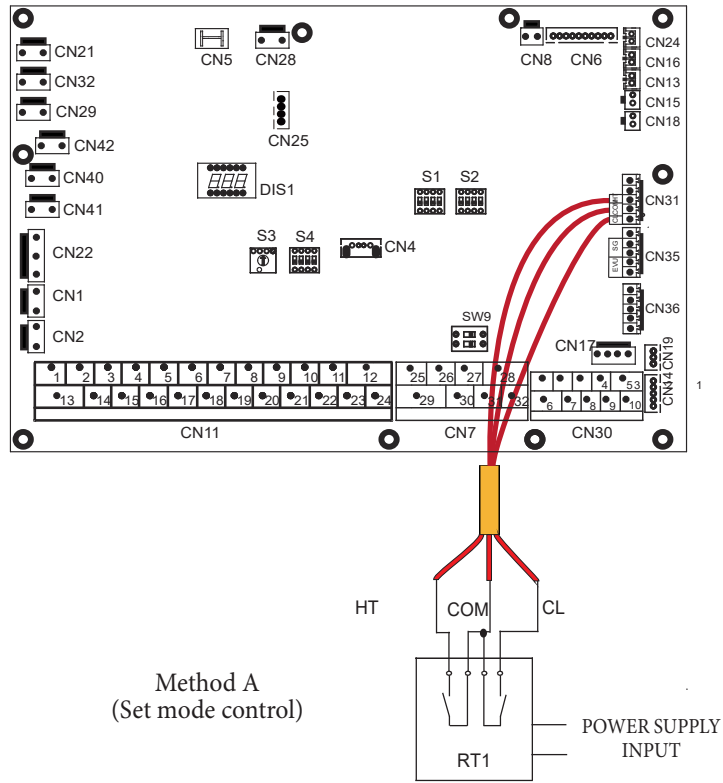

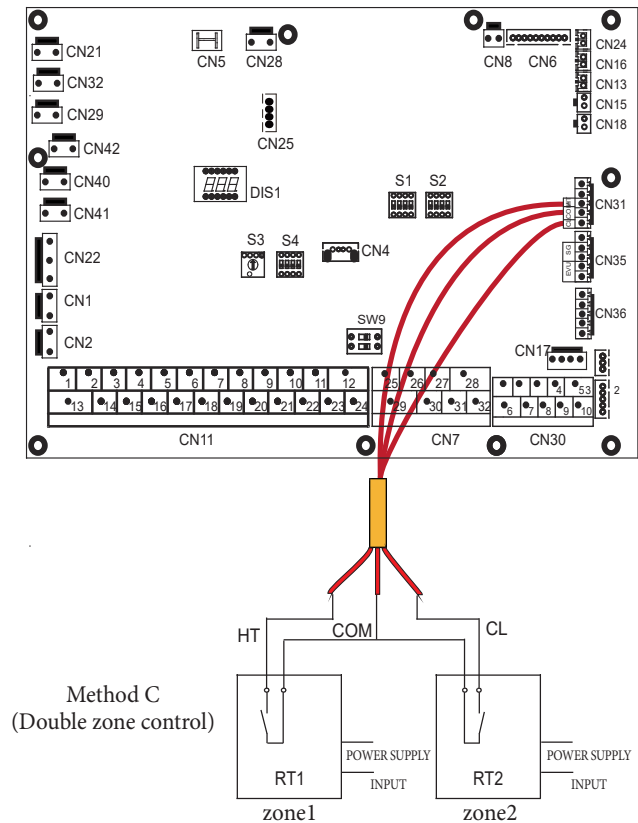

There are three methods to connect the thermostat cable (as described in the image above) and it depends on the application.

• **METHOD A (Set mode control).**

RT can control heating and cooling individually, like the control panel for 4-pipe FCU. When the hydraulic module is connected with the external temperature controller, on the control panel, in the FOR SERVICEMAN menu, set ROOM THERMOSTAT at MODE SETTING:

- A.1 When the unit detects a 12VDC voltage between CL and COM, the unit runs in cooling mode.
- A.2 When the unit detects a 12VDC voltage between HT and COM, the unit runs in heating mode.
- A.3 When the unit detects a 0VDC voltage for both sides (CL-COM, HT-COM), the unit stops operating for floor heating or cooling.
- A.4 When the unit detects a 12VDC voltage for both sides (CL-COM, HT-COM), the unit runs in cooling mode.

• **METHOD B (One zone control).**

RT supplies the switching signal to the unit. On the control panel, in the FOR SERVICEMAN menu, set ROOM THERMOSTAT at ONE ZONE:

- B.1 When the unit detects a 12VDC voltage between HT and COM, the unit switches on.
- B.2 When the unit detects a 0VDC voltage between HT and COM, the unit switches off.

• **METHOD C (Double zone control).**

The hydraulic module is connected with two room thermostats, on the control panel, in the FOR SERVICEMAN menu, set ROOM THERMOSTAT at DOUBLE ZONE:

- C.1 When the unit detects a 12VDC voltage between HT and COM, zone 1 switches on. When the unit detects a 0VDC voltage between H and COM, zone 1 switches off.
- C.2 When the unit detects a 12VDC voltage between CL and COM, zone 2 switches on depending on the weather temperature curve. When the unit detects a 0VDC voltage between CL and COM, zone 2 switches off.
- C.3 When HT-COM and CL-COM are detected as 0VDC, the unit switches off.
- C.4 When HT-COM and CL-COM are detected as 12VDC, both zone 1 and zone 2 switch on.

**NOTE**

- The wiring of the thermostat matches the settings on the control panel Chap. 10.5.6 Room thermostat.
- The power supply of the machine and of the room thermostat must be connected to the same Neutral Line.
- When the ROOM THERMOSTAT is not set at NO, the indoor temperature sensor Ta cannot be set at a valid value.
- Zone 2 can only operate in heating mode, when cooling mode is set on the control panel and Zone 1 is OFF, “CL” in Zone 2 closes, the system still remains “OFF”. The wires of the thermostats for Zone 1 and Zone 2 must be installed correctly.

**6) To activate the tank booster heater:**

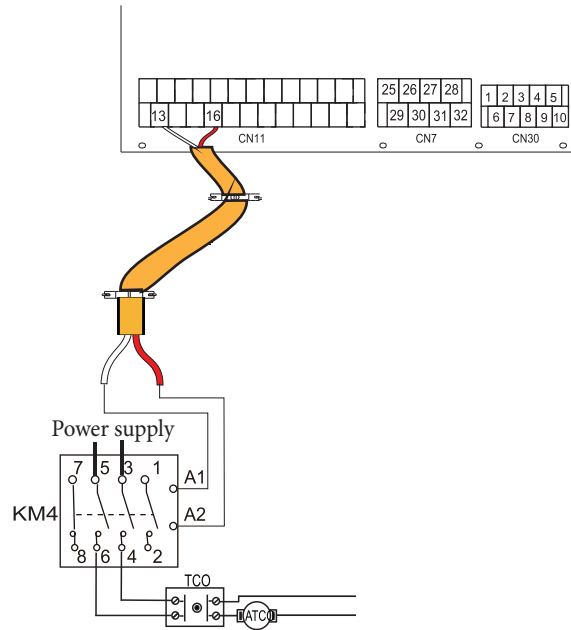

Voltage	220-240VAC
Maximum operating current (A)	0.2
Wiring size (mm <sup>2</sup> )	0.75
Type of signal of control port	Type 2

**NOTE**

The unit only sends the ON/OFF signal to the heater.

7) For the alarm signal output:

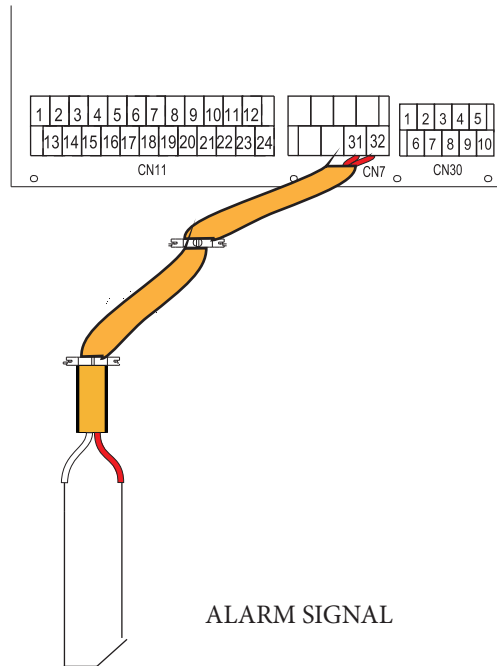

Voltage	220-240VAC
Maximum operating current (A)	0.2
Wiring size (mm <sup>2</sup> )	0.75
Type of signal of control port	Type 1

8) For zone 1 P\_o circulator:

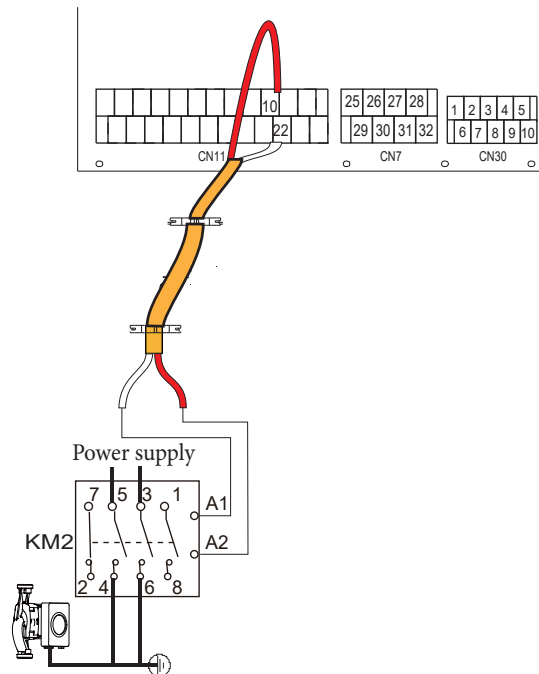

Voltage	220-240VAC
Maximum operating current (A)	0.2
Wiring size (mm <sup>2</sup> )	0.75
Type of signal of control port	Type 2



**9) For SMART GRID:**

The unit has the smart grid function, there are two ports on the PCB to connect the SG signal and the EVU signal as follows:

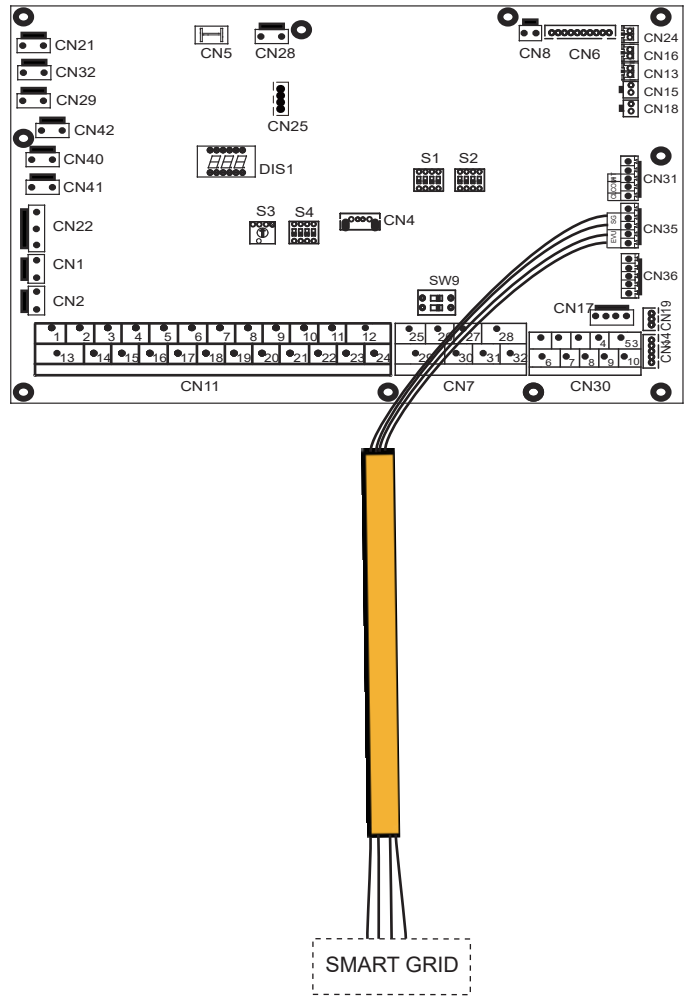

1. When the EVU contact is closed and the SG contact is closed, as long as DHW mode is set in a valid way, the heat pump gives DHW mode priority and the temperature setpoint of the DHW mode switches to 70°C. If  $T5 < 69^\circ\text{C}$ , the TBH is active,  $T5 > 70^\circ\text{C}$ , the TBH is not active.
2. When the EVU contact is closed and the SG contact is open, as long as DHW mode is set in a valid way and the mode is active, the heat pump gives DHW mode priority. If  $T5 < T5S - 2$ , the TBH is active, if  $T5 \geq T5S + 3$ , the TBH is not active.
3. When the EVU contact is open and the SG contact is closed, the unit runs normally.
4. When the EVU contact is open and the SG contact is open, the unit runs as follows: the unit will not work in DHW mode and the TBH will not be valid; the disinfect function will not be valid. The maximum operating time for cooling/heating is "SG RUNNING TIME", then the unit will switch off.

# 10

## START UP AND CONFIGURATION.

The unit must be configured by the installer to be adapted to the installation environment (outside weather, installed options, etc.) and to the competence of the user.

### ⚠ CAUTION

It is important that all of the information in this chapter be read in sequence by the installer and that the system be configured as applicable.

### 10.1 OVERVIEW OF DIP SWITCH SETTINGS.

#### 10.1.1 Setting of the function.

The DIP switches S1, S2 and S4 are located on the board of the main hydraulic control module (Chap. 9.3.1 Main control panel of hydraulic module).

### ⚠ WARNING

Switch off power before making any changes to the DIP switch settings.

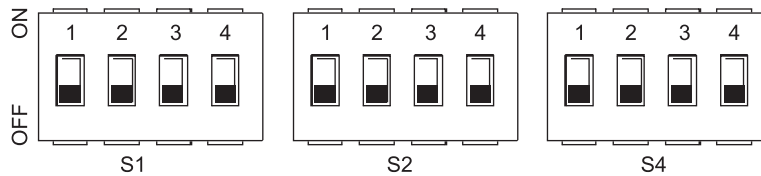

DIP Switch		ON=1	OFF=0	Default values
S1	1/2	Reserved		-
	3/4	0/0= Without IBH 1/0= With IBH 0/1= Reserved 1/1= Reserved		OFF / OFF

DIP Switch		ON=1	OFF=0	Default values
S2	1	The start-up of the pump O after 24 hours will not be valid	The start-up of the pump O after 24 hours will be valid	OFF
	2	without TBH	with TBH	OFF
	3/4	0/0= variable speed pump, maximum head: 8.5 m 0/1= constant speed pump 1/0= variable speed pump, maximum head: 10.5 m 1/1= variable speed pump, maximum head: 9 m		ON / ON (4-16 kW) OFF / ON (18-30 kW)

DIP Switch		ON=1	OFF=0	Default values
S4	1	<u>Master Unit</u> : Resets the addresses of all the slave units <u>Slave Unit</u> : Resets its own address	Maintains the current address	OFF
	2	IBH for DHW=valid	IBH for DHW=not valid	OFF
	3/4	Reserved		-

### 10.2 INITIAL START-UP AT LOW OUTDOOR TEMPERATURES.

During the initial start-up and when the water temperature is low, it is important to heat the water gradually. Otherwise the concrete floor could crack due to rapid temperature excursions. For further details, please contact the person in charge of making the concrete floor.

To perform this operation, the minimum set flow temperature of the water can be reduced to a value between 25°C and 35°C by adjusting it on "FOR SERVICEMAN" (for the maintenance technician).

Chap. 10.5.12 "SPECIAL FUNCTION".

### 10.3 CHECKS PRIOR TO OPERATION.

Checks before the initial start-up.

#### **⚠ DANGER**

Switch of power before performing any connection.

After installing the unit, check the following before switching on the circuit breaker:

- Wiring on field: Make sure that the wiring on field between the local power supply panel and the unit and the valves (if applicable), the unit and the room thermostat (if applicable), the unit and the domestic hot water tank, has been connected according to the instructions given in Chap. 9.7 "Wiring on field", according to the wiring diagrams and local laws and regulations.
- Fuses, circuit breakers or protective devices: Check that the fuses or protective devices installed locally are the size and type specified in Chap. 14 "Technical specifications". Make sure that the fuses or protective devices have not been bypassed.
- System indoor unit backup heater switch: Do not forget to switch on the circuit breaker of the indoor unit backup heater in the control box. See the wiring diagram.
- Heater of DHW storage tank switch: Do not forget to switch on the circuit breaker of the booster heater (this only applies with the optional domestic hot water tank installed).
- Earthing wiring: Make sure that the earth wires are connected properly and that the earth terminals are tightened.
- Internal wiring: Visually check that there are no loose connections or damaged electric components.
- Assembly: Check that the unit is assembled correctly, to avoid anomalous noise and vibrations when starting the unit.
- Damaged equipment: Check that there are no damaged components or compressed pipes inside the appliance.
- Refrigerant leak: Check that there are no refrigerant leaks inside the unit. Contact your local dealer if there is a refrigerant leakage.
- Supply voltage: Check the supply voltage on the local power supply panel. The voltage must match that indicated on the appliance's rating plate.
- Air purge valve: Make sure that the air purge valve is open (at least 2 turns).
- Shut-off valves: Make sure that the shut-off valves are completely open.

### 10.4 THE CIRCULATION PUMP.

Models 4-16 kW.

The relationships between the head and the nominal waterflow, the return PMW and the nominal water flow are shown in the following charts.

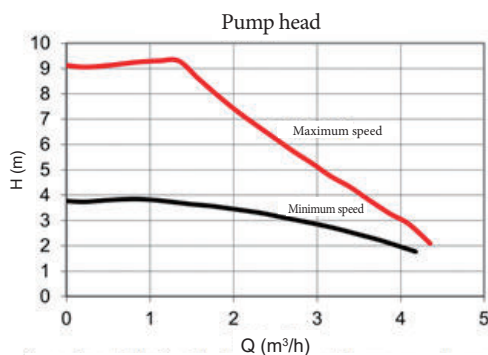

The adjustment area is between the maximum speed curve and the minimum speed curve.

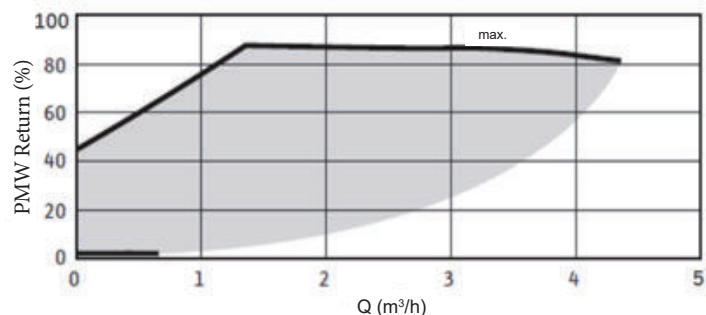

External available static pressure VS Flow rate

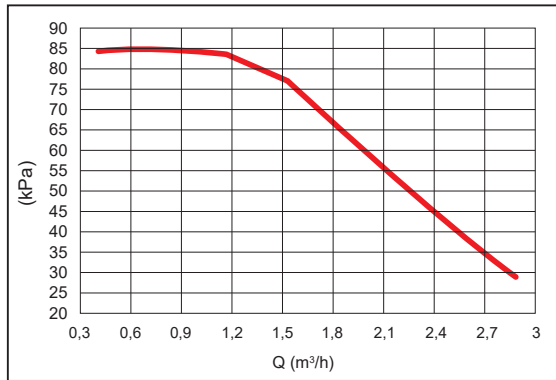

4-8 kW

External available static pressure VS Flow rate

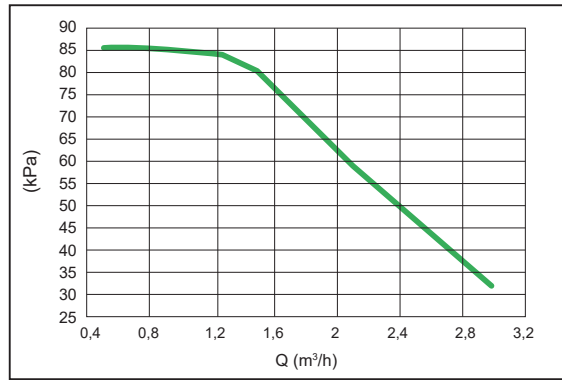

12-16 kW

### Models 18-30 kW.

The pump speed can be selected by adjusting the red knob on the pump. The point indicated by the notch indicates the pump speed.

The default setting is the maximum speed (3). If the water flow in the system is too high, the speed can be set at low (1).

The relationship between the external available static pressure and the water flow rate is indicated in the chart below:

External available static pressure VS Flow rate

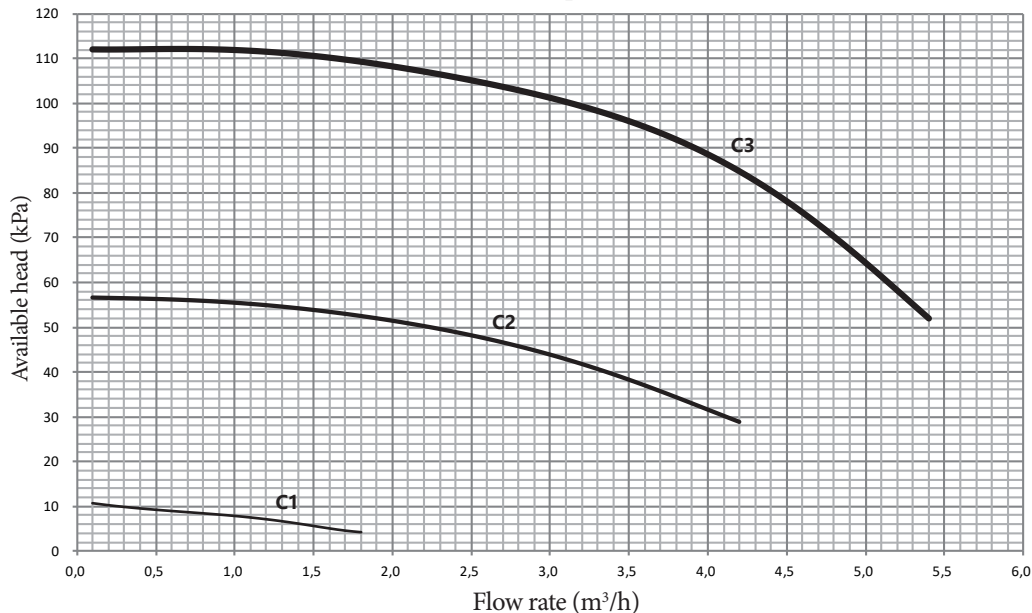

### ⚠ CAUTION

If the valves are in the wrong position, the circulation pump is damaged.

### ⚠ DANGER

If the operation status of the pump needs to be checked when the unit switches on, please do not touch the internal components of the electric control box to avoid electric shocks.

#### 10.4.1 Troubleshooting at first installation (models 4-16 kW).

- If nothing is displayed on the control panel, check for one of the following faults before diagnosing any error codes.
  - Disconnection or wiring error (between the power supply and the unit and between the unit and the control panel).
  - The fuse on the PCB could be blown.
- If the control panel displays “E8” or “E0” as error code, there could be air in the system, or the water level in the system might be lower than the minimum required.

- If the error code E2 is displayed on the control panel, check wiring between the control panel and the unit. Other error codes and causes of faults are found in section 13.4 Error codes.

Have qualified personnel repair the faults.

#### 10.4.2 Troubleshooting at first installation (models 18-30 kW).

Fault	Cause	Remedy
The pump does not work despite power being connected. Black display.	Faulty electrical fuse.	Check the fuses.
	The pump is not powered.	Restore power after the failure.
The pump makes noise.	Cavitation due to insufficient intake pressure.	Increase the system intake pressure within the allowed field.
		Check the setting of the flow head and, if necessary, set it on the lower head.

- The fault signal is indicated by the LED display.
- The fault warning LED remains lit red.
- The pump switches off (according to the error code) and tries to perform a cyclical restart.

#### **i** INFORMATION

- EXCEPTION: Error code E10 (block).

After about 10 minutes the pump switches off permanently and the error code is displayed.

Code	Fault	Cause	Remedy
E04	Grid undervoltage	Grid power supply too low	Check the mains voltage
E05	Grid overvoltage	Grid power supply too high	Check the mains voltage
E09	Turbine operation	The pump runs backward (the fluid flows through the pump from the delivery to the intake)	Check the flow, install the check valve if necessary
E10	Block	The rotor is blocked	Request the intervention of customer service
E21*	Overload	Motor slow	Request the intervention of customer service
E23	Short-circuit	Motor current too high	Request the intervention of customer service
E25	Contact/winding	Motor winding faulty	Request the intervention of customer service
E30	Module overheated	Inside of the too hot module	Improve room ventilation, check the operating conditions, request customer service, if necessary.
E31	Power section overheated	Room temperature too high	Improve room ventilation, check the operating conditions, request customer service, if necessary.
E36	Electronic failures	Faulty electronics	Request the intervention of customer service

(\*): In addition to the LED indication. The fault warning LED remains lit red.

**Warning signals (models 18-30 kW).**

- The warning signal is indicated by the LED display.
- The fault warning LED and the SSM relay do not respond.
- The pump keeps running with a limited output.
- The faulty operating status indicated must not occur for a long period of time. The cause must be eliminated.

Code	Fault	Cause	Remedy
E07	Generator operation	A fluid is flowing through the hydraulic system of the pump	Check the system
E11	Dry operation	Air in pump	Check the volume/pressure of the water
E21*	Overload	Motor slow, the pump is operated outside of its specifications (e.g. high temperature of the module). The speed is lower than normal operation.	Check the environmental conditions

(\*): Also fault signal E21.

**NOTE**

- If it is impossible to eliminate the operating fault, please consult a specialised technician or the closest customer service centre or representative.
- To guarantee the life expectancy of the pump, it is recommended to have the unit operate at least once every 2 weeks (make sure that the pump works) or to keep it on for a long period of time (in standby status at start up, the unit will operate the pump for 1 minute every 24 hours).

**10.5 ON-FIELD SETTINGS.**

The unit must be configured based on the installation environment (outside weather, installed options, etc.) and on the request of the user. Several settings are available. These settings can be accessed and programmed from the section “FOR SERVICEMAN” on the control panel.

**Switching on the unit.**

While the unit is switching on, “1%-99%” is displayed on the control panel during initialisation. The control panel cannot be used as long as this process is underway.

**Procedure.**

To edit one or more settings, proceed as follows.

**NOTE**

The temperature values used on the control panel are in °C.

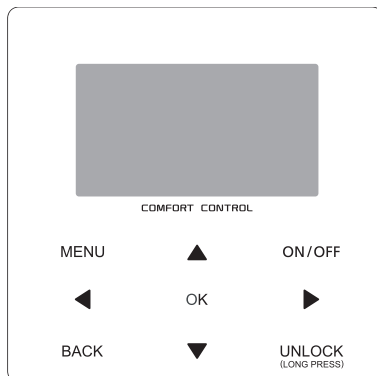

Keys	Function
MENU	• Go to main menu
◀▶▼▲	• Move the cursor on the display • Move inside the menu • Adjust the settings
ON/OFF	• Activate/deactivate the space heating/cooling operation or DHW mode • Activate or deactivate the functions inside the menu
BACK	• Go back to higher level
UNLOCK	• Long press to unlock/lock the control panel • Unlock/lock some functions such as “DHW temperature adjustment”
OK	• Go to the next step when programming a schedule in the menu; • Confirm a selection to access a submenu

### Information on “FOR SERVICEMAN”.

The “FOR SERVICEMAN” section is designed to allow the installer to set the parameters.

- Definition of the composition of the devices.
- Setting the parameters.

#### “How to access the FOR SERVICEMAN” section.

Go to MENU>FOR SERVICEMAN. Press “OK”:

FOR SERVICEMAN	
Please input password:	
0 0 0	
OK ENTER	ADJUST

Press ◀▶ to navigate and press ▼▲ to adjust the numerical value. Press OK. The password is 234, the following pages will be displayed after having entered the password:

FOR SERVICEMAN	1/3
1 DHW MODE SETTING	
2 COOL MODE SETTING	
3 HEAT MODE SETTING	
4 AUTO MODE SETTING	
5 TEMP. TYPE SETTING	
6 ROOM THERMOSTAT	
OK ENTER	ADJUST

FOR SERVICEMAN	2/3
7. OTHER HEATING SOURCE	
8. HOLIDAY AWAY SETTING	
9 SERVICE CALL	
10 RESTORE FACTORY SETTINGS	
11. TEST RUN	
12. SPECIAL FUNCTION	
OK ENTER	ADJUST

FOR SERVICEMAN	3/3
13. AUTO RESTART	
14. POWER INPUT LIMITATION	
15. INPUT DEFINE	
16. CASCADE SET	
17. HMI ADDRESS SET	
OK ENTER	ADJUST

Press ▼▲ to scroll and press OK to access the submenu.

### 10.5.1 DHW Mode setting.

DHW = domestic hot water.

Go to MENU>FOR SERVICEMAN>1.DHW MODE SETTING.

Press OK. The following page will be displayed:

1. DHW MODE SETTING	1/5
1.1 DHW MODE	YES
1.2 DISINFECT	YES
1.3 DHW PRIORITY	YES
1.4 DHW PUMP	YES
1.5 DHW PRIORITY TIME SET	NO
ADJUST	

1. DHW MODE SETTING	2/5
1.6 dt5_ON	5 °C
1.7 dt1S5	10°C
1.8 T4DHWMAX	43°C
1.9 T4DHWMIN	-10°C
1.10 t_INTERVAL_DHW	5 MIN
ADJUST	

1. DHW MODE SETTING	3/5
1.11 dt5_TBH_OFF	5 °C
1.12 T4_TBH_ON	5 °C
1.13 t_TBH_DELAY	30 MIN
1.14 T5S_DI	65°C
1.15 t_DI HIGHTEMP.	15MIN
ADJUST	

1. DHW MODE SETTING	4/5
1.16 t_DI_MAX	210 MIN
1.17 t_DHWHP_RESTRICT	30 MIN
1.18 t_DHWHP_MAX	120 MIN
1.19 DHW PUMP TIME RUN	YES
1.20 PUMP RUNNING TIME	5 MIN
ADJUST	

1. DHW MODE SETTING	5/5
1.21 DHW PUMP DI RUN	NO
ADJUST	



### 10.5.2 Cool Mode Setting.

Go to MENU>FOR SERVICEMAN>2. COOL MODE SETTING.  
Press OK. The following page will be displayed:

2. COOL MODE SETTING	1/3
2.1 COOL MODE	YES
2.2 t_T4_FRESH_C	2.0HOURS
2.3 T4CMAX	43°C
2.4 T4CMIN	20°C
2.5 dT1SC	5°C
ADJUST	

2. COOL MODE SETTING	2/3
2.6 dTSC	2°C
2.7 t_INTERVAL_C	5MIN
2.8 T1SetC1	10°C
2.9 T1SetC2	16°C
2.10 T4C1	35°C
ADJUST	

2. COOL MODE SETTING	3/3
2.11 T4C2	25°C
2.12 ZONE1 C-EMISSION	FCU
2.13 ZONE2 C-EMISSION	FHL
ADJUST	

### 10.5.3 Heat Mode Setting.

Go to MENU>FOR SERVICEMAN>3. HEAT MODE SETTING.  
Press OK. The following page will be displayed:

3. HEAT MODE SETTING	1/3
3.1 HEAT MODE	YES
3.2 t_T4_FRESH_H	2.0HOURS
3.3 T4HMAX	16°C
3.4 T4HMIN	-15°C
3.5 dT1SH	5°C
ADJUST	

3. HEAT MODE SETTING	2/3
3.6 dTSH	2°C
3.7 t_INTERVAL_H	5MIN
3.8 T1SetH1	35°C
3.9 T1SetH2	28°C
3.10 T4H1	-5°C
ADJUST	

3. HEAT MODE SETTING	3/3
3.11 T4H2	7°C
3.12 ZONE1 H-EMISSION	RAD.
3.13 ZONE2 H-EMISSION	FHL
3.14 t_DELAY_PUMP	2MIN
1.1	
ADJUST	

### 10.5.4 Auto Mode Setting.

Go to MENU>FOR SERVICEMAN>4. AUTO MODE SETTING.  
Press OK. The following page will be displayed:

4.AUTO MODE SETTING	
4.1 T4AUTOCMIN	25°C
4.2 T4AUTOHMAX	17°C
ADJUST	

### 10.5.5 Temp. Type Setting.

#### Information on Temp. Type Setting.

The TEMP. TYPE SETTING is used to select whether the water flow temperature or the room temperature is used to control switching the heat pump on/off.

When the ROOM TEMP. is enabled, the target water flow temperature will be calculated based on the climatic curves.



#### How to enter the Temp. Type Setting.



Go to MENU>FOR SERVICEMAN>5. TEMP. TYPE SETTING.

Press OK. The following page will be displayed:







5. TEMP. TYPE SETTING	
5.1 WATER FLOW TEMP.	YES
5.2 ROOM TEMP.	NO
5.3 DOUBLE ZONE	NO
ADJUST	

If only WATER FLOW TEMP. is set at YES, or only ROOM TEMP. is set at YES, the following pages will be displayed:

01-01-2018	23:59	↑13°
	ON	
Δ 35 °C		38 °C
only WATER FLOW TEMP. YES		







01-01-2018	23:59	↑13°
	ON	
25.0 °C		38
only ROOM TEMP. YES		

If WATER FLOW TEMP. and ROOM TEMP. are set at YES, while DOUBLE ZONE is set NO or YES, the following pages will be displayed:

01-01-2018	23:59	↑13°	01-01-2018	23:59	↑13°
	ON			ON	
Δ 35 °C		38 °C	25.0 °C		
Homepage (zone 1)			Additional page (zone 2) (The double zone is effective)		

In this case, the setting value of zone 1 is T1S, the setting value of zone 2 is T1S2 (the corresponding T1S2 is calculated based on the climatic curves).

If DOUBLE ZONE is set at YES and ROOM TEMP. is set at NO, while WATER FLOW TEMP. is set at YES or NO, the following pages will be displayed:

01-01-2018	23:59	↑13°	01-01-2018	23:59	↑13°
	ON			ON	
Δ 35 °C		38 °C	Δ 35 °C		
Homepage (zone 1)			Additional page (zone 2)		

In this case, the setting value of zone 1 is T1S, the setting value of zone 2 is T1S2.

If DOUBLE ZONE and ROOM TEMP. are set at YES, while WATER FLOW TEMP. is set at YES or NO, the following pages will be displayed:

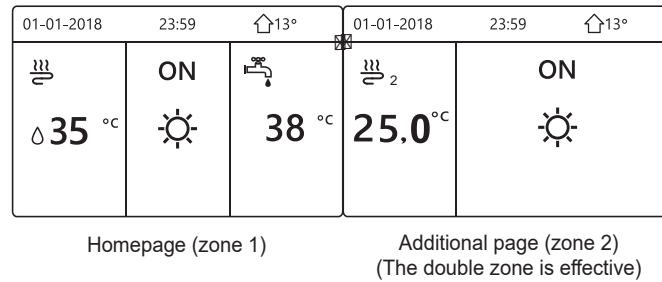

In this case, the setting value of zone 1 is T1S, the setting value of zone 2 is T1S2 (the corresponding T1S2 is calculated based on the climatic curves).

### 10.5.6 Room thermostat.

#### Information on Room Thermostat.

The ROOM THERMOSTAT setting is used if the room thermostat is available.

#### How to set the Room Thermostat.

Go to MENU>FOR SERVICEMAN>6. ROOM THERMOSTAT.

Press OK. The following page will be displayed:

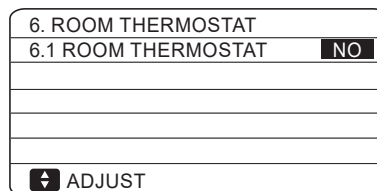

### NOTE

ROOM THERMOSTAT. = NO, no room thermostat.

ROOM THERMOSTAT = MODE SETTING, wiring of the room thermostat must follow method A.

ROOM THERMOSTAT = ONE ZONE, wiring of the room thermostat must follow method B.

ROOM THERMOSTAT = DOUBLE ZONE, wiring of the room thermostat must follow method C

(see 9.7.6 Connection for other components/For the room thermostat).

### 10.5.7 Other Heating Source.

The OTHER HEATING SOURCE is used to set the parameters of the indoor unit backup heater (IBH).

Go to MENU>FOR SERVICEMAN>7. OTHER HEATING SOURCE.

Press OK. The following page will be displayed:

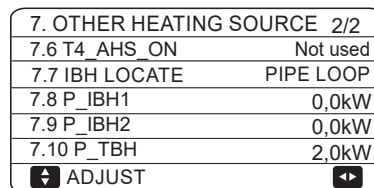
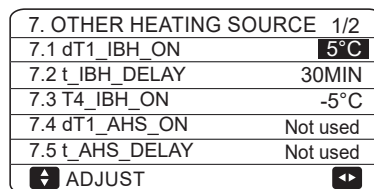

### 10.5.8 Holiday Away Setting.

The HOLIDAY AWAY SETTING is used to set the outlet water temperature to prevent freezing during holidays. Go to MENU>FOR SERVICEMAN>8. HOLIDAY AWAY SETTING .

Press OK. The following page will be displayed:

8.HOLIDAY AWAY SETTING	
8.1 T1S_H.A._H	20°C
8.2 T5S_H.A._DHW	20°C
⬇️ ADJUST	⬅️

### 10.5.9 Service Call Setting.

The installers can set the phone number of the local dealer in the SERVICE CALL SETTING. If the unit does not work correctly, call this number to ask for help.

Go to MENU>FOR SERVICEMAN>9.SERVICE CALL.

Press OK. The following page will be displayed:

9 SERVICE CALL	
PHONE NO. *****	
MOBILE NO. *****	
OK ENTER	⬇️ ADJUST ⬅️

Press ▼▲ to scroll and set the phone number. The maximum length of the phone number is 13 digits. If the phone number has less than 12 digits, enter ■ as shown below:

9. SERVICE CALL	
PHONE NO. *****	■■■
MOBILE NO. *****	■
OK ENTER	⬇️ ADJUST ⬅️

The number displayed on the control panel is the phone number of your local dealer.

### 10.5.10 Restore Factory Settings.

RESTORE FACTORY SETTINGS is used to restore all the parameters set in the control panel to the factory setting.

Go to MENU>FOR SERVICEMAN>10.RESTORE FACTORY SETTINGS.

Press OK. The following page will be displayed:

10. RESTORE FACTORY SETTINGS	
All the settings will come back to factory default. Do you want to restore factory settings	
<input type="radio"/> NO	<input type="radio"/> YES
OK ENTER	⬅️

Press ◀▶ to scroll the cursor to YES and press OK. The following page will be displayed:

10. RESTORE FACTORY SETTINGS	
Please wait.....	
5%	

After a few seconds, all the parameters set in the control panel will be restored to the factory settings.

### 10.5.11 TEST RUN.

TEST RUN is used to check correct operation of the valves, de-aeration, operation of the circulation pump, cooling, heating and domestic hot water heating.

Go to MENU>FOR SERVICEMAN>11.TEST RUN.

Press OK. The following page will be displayed:

11. TEST RUN	
Active the settings and active the 'TEST RUN'?	
NO	YES
OK ENTER	↕

If YES is selected, the following pages will be displayed:

11. TEST RUN	
11.1 POINT CHECK	
11.2 = AIR PURGE	
11.3 CIRCULATED PUMP RUNNING	
11.4 COOL MODE RUNNING	
11.5 HEAT MODE RUNNING	
OK ENTER	↕

11. TEST RUN	
11.6 DHW MODE RUNNING	
OK ENTER	↕

If POINT CHECK is selected, the following pages are displayed:

11. TEST RUN		1/2
3 WAY-VALVE 1	OFF	
3 WAY-VALVE 2	OFF	
PUMP I	OFF	
PUMP O	OFF	
PUMP C	OFF	
ON/OFF	ON/OFF	↕

11. TEST RUN		2/2
PUMPSOLAR	OFF	
PUMPDHW	OFF	
INNER BACKUP HEATER	OFF	
TANK HEATER	OFF	
3 WAY-VALVE 3	OFF	
ON/OFF	ON/OFF	↕

Press ▼▲ to scroll to the components you want to check and press ON/OFF. For example, when the 3-way valve is selected and ON/OFF is pressed, if the 3-way valve is open/closed, then operation of the 3-way valve is normal, as are the other components.

**⚠ CAUTION**

Before the point check, make sure that the tank and water system are filled with water and air is ejected, otherwise the pump could be damaged.

If you select AIR PURGE and press OK, the following page is displayed:

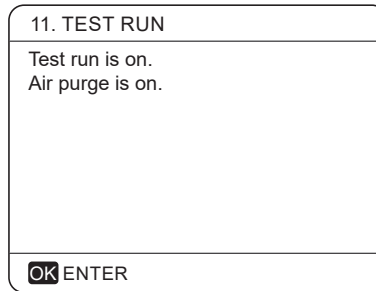

When in the air purge mode, SV1 opens, SV2 closes. 60 seconds later the pump in the unit (PUMPI) will run for 10 minutes during which the flow switch will not work. After the pump stops, SV1 closes and SV2 opens. 60 seconds after both PUMPI and PUMPO will run until they receive the next command.

When CIRCULATED PUMP OPERATION is selected, the following page is displayed:

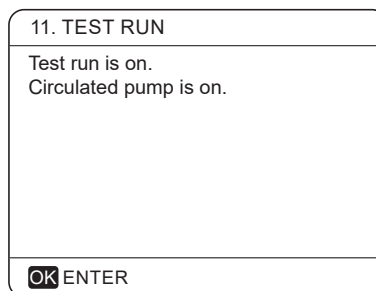

When the circulated pump test is running, all the components in operation will stop. 60 seconds after SV1 opens and SV2 closes. 60 seconds after PUMPI will run. 30 seconds after, if the flow switch verifies the presence of a normal flow rate, PUMPI will run for 3 minutes, then the pump stops for 60 seconds, SV1 closes and SV2 opens. 60 seconds after both PUMPI and PUMPO will start to run, 2 minutes later, the flow switch will check the water flow. If the flow switch closes for 15 seconds, PUMPI and PUMPO will run until they receive the next command.

When the cooling operation mode is selected, the following page is displayed:

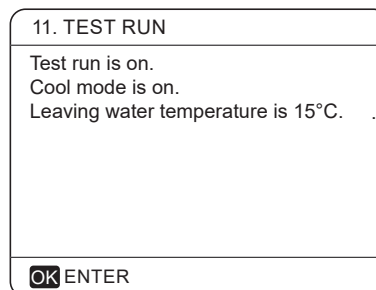

During operation of the COOL MODE test, the default temperature of the outlet water is 7°C. The unit will operate until the water temperature drops to a certain value or a subsequent command is received.

When the HEAT MODE ACTIVATION function is selected, the following page is displayed:

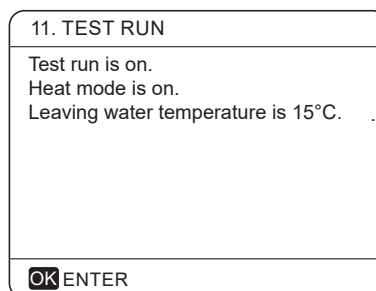

During execution of the HEAT MODE test, the default temperature of the outlet water is 35°C. The IBH switches on after the compressor has been operating for 10 minutes. After 3 minutes of operation of the IBH, the IBH switches off, the heat pump runs until the water temperature increases to a certain value or another command is received.

When the DHW MODE ACTIVATION function is selected, the following page is displayed:

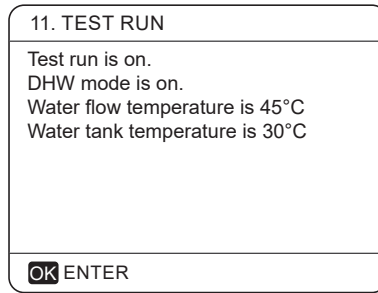

During execution of the DHW MODE test, the default temperature of the domestic hot water is 55°C. The TBH (tank booster heater) switches on after the compressor has been operating for 10 minutes. The TBH will switch off 3 minutes later, the heat pump will run until the water temperature increases to a certain value or another command is received.

During execution of the test, only the OK button remains valid. If you want to interrupt the test, press OK. For example, when the unit is in air purge mode, after having pressed OK, the following page is displayed:

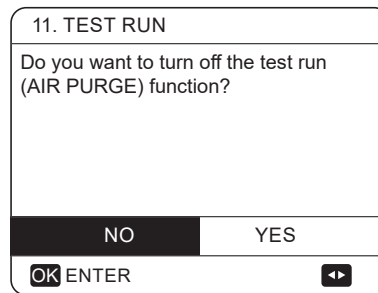

Press ◀▶ to scroll the cursor to YES and press OK. The test operation switches off.

#### 10.5.12 Special Function.

When in special function mode, the control panel cannot work, it does not go back to the main screen and the screen shows the page that executes the special function, the control panel does not block.

#### NOTE

During operation of special functions, other functions cannot be used (WEEKLY SCHEDULE/TIMER, HOLIDAY AWAY, HOLIDAY HOME).

Go to MENU>FOR SERVICEMAN>12.SPECIAL FUNCTION.

Before floor heating, if a large amount of water remains on the floor, the floor could deform or even break during the floor heating operation. In order to protect the floor, it must be dried and the floor temperature must steadily increase.

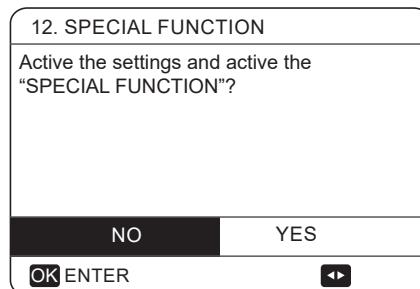

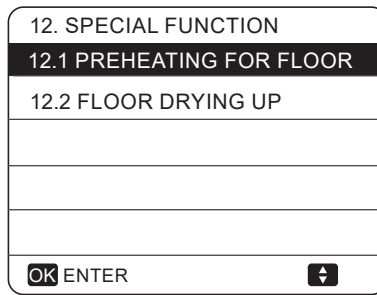

Press ▼▲ to scroll and press OK to enter.

During the initial operation of the unit, air could remain in the water system and cause malfunctioning. It will be necessary to perform the air purge function (make sure that the air purge valve is open).

If you select PREHEATING FOR FLOOR, after having pressed OK, the following page is displayed:

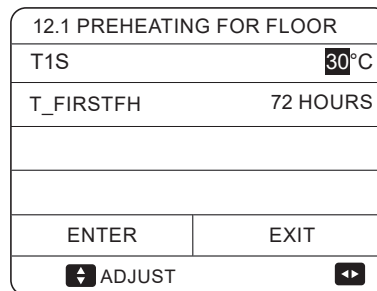

When the cursor is on PREHEATING FOR FLOOR, use ▼▲ to scroll to ENTER and press OK. The following page will be displayed:

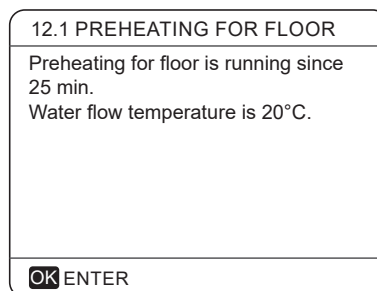

During preheating of the floor, only the OK button is valid. If you want to deactivate floor drying up, press OK. The following page will be displayed:

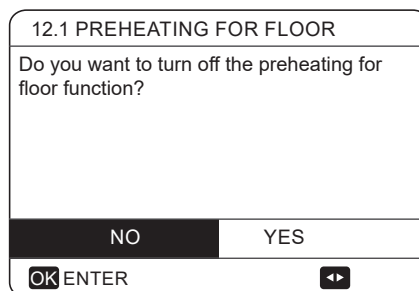

Use ◀▶ to scroll the cursor to YES and press OK, preheating for floor switches off.



Operation of the unit during preheating of the floor is described in the figure below:

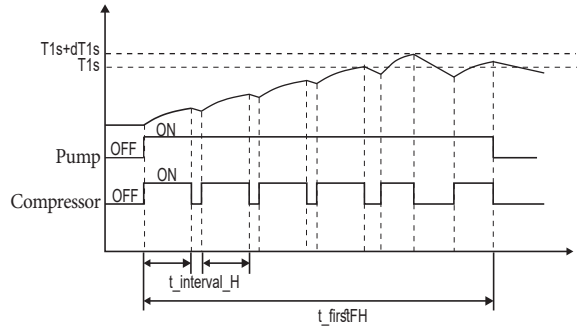

If FLOOR DRYING UP has been selected, after having pressed OK, the following pages will appear:

12.2 FLOOR DRYING UP	
T_DRYUP	8 DAYS
T_HIGHPEAK	5 DAYS
T_DRYD	5 DAYS
T_DRYPEAK	45°C
T_DRYPEAK	15:00
<input type="button" value="ADJUST"/>	

12.2 FLOOR DRYING UP	
START DATE	01-01-2019
<input type="button" value="ENTER"/> <input type="button" value="EXIT"/>	
<input type="button" value="ADJUST"/>	

Use ▼▲ to scroll to ENTER and press OK. The following page will be displayed:



12.3 FLOOR DRYING UP	
The unit will operate floor drying up on 01-08-2018	
<input type="button" value="OK"/> <input type="button" value="ENTER"/>	

During floor drying up, only the OK button is valid. When the heat pump is not running, the floor drying up mode is deactivated when the backup heating source is not available. If you want to deactivate floor drying up, press OK.

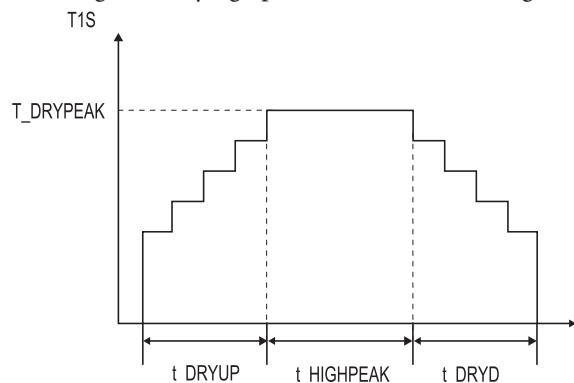
The target outlet water temperature during floor drying up is described in the image below:





15. INPUT DEFINE(M1M2)	
15.11 PUMPI SILENT MODE	NO
15.12 DFT1/DFT2	ALARM
 ADJUST 	

**10.5.16 Cascade Set.**

**How to set Cascade Set.**



Go to MENU>FOR SERVICEMAN>16. CASCADE SET.

16.CASCADE SET	
16.1 PER_START	10%
16.2 TIME_ADJUST	5 MIN
16.3 ADDRESS RESET	FF
	

**10.5.17 HMI Address Set.**

**How to set HMI Address Set.**

Go to MENU>FOR SERVICEMAN>17.HMI ADDRESS SET.

17 HMI ADDRESS SET	
17.1 HMI SET	MASTER
17.2 HMI ADDRESS FOR BMS	1
17.3 STOP BIT	1
 	

### 10.5.18 Setting the parameters.

The parameters in this chapter are shown in the table below.

Order number	Code	Status	Default	Minimum	Maximum	Interval definition	Unit
1.1	DHW MODE	Enable or disable DHW mode: 0=NO, 1=YES	1	0	1	1	/
1.2	DISINFECT	Enable or disable disinfect mode: 0=NO, 1=YES	1	0	1	1	/
1.3	DHW PRIORITY	Enable or disable DHW priority mode: 0=NO, 1=YES	1	0	1	1	/
1.4	DHW PUMP	Enable or disable the DHW pump: 0=NO, 1=YES	0	0	1	1	/
1.5	DHW PRIORITY TIME SET	Enable or disable the DHW priority time set: 0=NO, 1=YES	0	0	1	1	/
1.6	dT5_ON	The temperature difference to start the heat pump	10	1	30	1	°C
1.7	dT1S5	The difference value between Twout and T5 in DHW mode	10	5	40	1	°C
1.8	T4DHWMAX	The maximum outdoor temperature that the heat pump can manage for heating domestic hot water	43	35	43	1	°C
1.9	T4DHWMIN	The minimum outdoor temperature that the heat pump can manage for heating domestic hot water	-10	-25	30	1	°C
1.10	t_INTERVAL_DHW	The start time interval of the compressor in DHW mode	5	5	5	1	MIN.
1.11	dT5_TBH_OFF	The temperature difference between T5 and T5S which switches off the booster heater	5	0	10	1	°C
1.12	T4_TBH_ON	The highest outdoor temperature with which the TBH can operate	5	-5	50	1	°C
1.13	t_TBH_DELAY	The operating time of the compressor before starting the booster heater	30	0	240	5	MIN.
1.14	T5S_DI	The water temperature in the domestic hot water tank in the DISINFECT function	65	60	70	1	°C
1.15	t_DI_HIGHTEMP	The holding time of the highest water temperature in the domestic hot water tank in the DISINFECT function	15	5	60	5	MIN.
1.16	t_DI_MAX	The maximum time duration of disinfect	210	90	300	5	MIN.
1.17	t_DHWHP_RESTRICT	Operation time for space heating/cooling	30	10	600	5	MIN.
1.18	t_DHWHP_MAX	The maximum continuous operation period of the heat pump in DHW PRIORITY mode	90	10	600	5	MIN.
1.19	DHW PUMP TIME RUN	Enable or disable operation of the DHW pump as timed or continuous to operate for PUMP RUNNING TIME : 0=NO, 1=YES	1	0	1	1	/
1.20	PUMP RUNNING TIME	The certain time during which the DHW pump continues to run	5	5	120	1	MIN.
1.21	DHW PUMP DI RUN	Enable or disable operation of the DHW pump when the unit is in disinfectant mode and T5≥T5S_DI-2: 0=NO, 1=YES	1	0	1	1	/

Order number	Code	Status	Default	Minimum	Maximum	Interval definition	Unit
2.1	COOL MODE	Enable or disable cooling mode: 0=NO, 1=YES	1	0	1	1	/
2.2	t_T4_FRESH_C	The update time of the climatic curves for cooling mode	0.5	0.5	6	0.5	hours
2.3	T4CMAX	The highest outdoor temperature for cooling mode	52	35	52	1	°C
2.4	T4CMIN	The lowest outdoor operating temperature for cooling mode	10	-5	25	1	°C
2.5	dT1SC	The temperature difference to start the heat pump (T1)	5	2	10	1	°C
2.6	dTSC	The temperature difference to start the heat pump (Ta)	2	1	10	1	°C
2.7	t_INTERVAL_C	The start time interval of the compressor in COOL mode	5	5	5	1	MIN.
2.8	T1SetC1	The setting temperature 1 of the climatic curves for cooling mode	10	5	25	1	°C
2.9	T1SetC2	The setting temperature 2 of the climatic curves for cooling mode	16	5	25	1	°C
2.10	T4C1	The outdoor temperature 1 of the climatic curves for cooling mode	35	-5	46	1	°C
2.11	T4C2	The outdoor temperature 2 of the climatic curves for cooling mode	25	-5	46	1	°C
2.12	ZONE1 C-EMISSION	The type of zone1 terminal for cooling mode: CVC fan coil), RAD (do not use), CRP (floor radiant)	CVC	-	-	-	/
2.13	ZONE2 C-EMISSION	The type of zone2 terminal for cooling mode: CVC fan coil), RAD (do not use), CRP (floor radiant)	CVC	-	-	-	/

Order number	Code	Status	Default	Minimum	Maximum	Interval definition	Unit
3.1	HEAT MODE	Activate or deactivate heating mode	1	0	1	1	/
3.2	t_T4_FRESH_H	The update time of the climatic curves for heating mode	0.5	0.5	6	0.5	hours
3.3	T4HMAX	The maximum outdoor operating temperature for heating mode	25	20	35	1	°C
3.4	T4HMIN	The minimum outdoor operating temperature for heating mode	-15	-25	30	1	°C
3.5	dT1SH	The temperature difference to start the unit (T1)	5	2	20	1	°C
3.6	dTSH	The temperature difference to start the unit (Ta)	2	1	10	1	°C
3.7	t_INTERVAL_H	The start time interval of the compressor in HEATING mode	5	5	5	1	MIN.
3.8	T1SetH1	The setting temperature 1 of the climatic curves for heating mode	35	25	65	1	°C
3.9	T1SetH2	The setting temperature 2 of the climatic curves for heating mode	28	25	65	1	°C
3.10	T4H1	The outdoor temperature 1 of the climatic curves for heating mode	-5	-25	35	1	°C
3.11	T4H2	The outdoor temperature 2 of the climatic curves for heating mode	7	-25	35	1	°C

Order number	Code	Status	Default	Minimum	Maximum	Interval definition	Unit
3.12	ZONE1 H-EMISSION	The type of zone1 terminal for heating mode: CVC fan coil), RAD (radiator), CRP (floor radiant)	RAD	-	-	-	/
3.13	ZONE2 H-EMISSION	The type of zone2 terminal for heating mode: CVC fan coil), RAD (radiator), CRP (floor radiant)	CRP	-	-	-	/
3.14	t_DELAY_PUMP	The delay time to stop the pump after the compressor stops	2	0.5	20	0.5	MIN.
4.1	T4AUTOCMIN	The minimum outdoor operating temperature for automatic cooling mode	25	20	29	1	°C
4.2	T4AUTOHMAX	The maximum outdoor operating temperature for automatic cooling mode	17	10	17	1	°C
5.1	WATER FLOW TEMP.	Enable or disable WATER FLOW TEMP.: 0=NO, 1=YES	1	0	1	1	/
5.2	ROOM TEMP.	Enable or disable ROOM TEMP.: 0=NO, 1=YES	0	0	1	1	/
5.3	DOUBLE ZONE	Enable or disable DOUBLE ZONE ROOM THERMOSTAT: 0=NO, 1=YES	0	0	1	1	/
6.1	ROOM THERMOSTAT.	Room thermostat mode: 0=NO, 1= MODE SETTING, 2=ONE ZONE, 3=DOUBLE ZONE	0	0	3	1	/
7.1	dT1_IBH_ON	The temperature difference between T1S and T1 to start the indoor unit backup heater	5	2	10	1	°C
7.2	t_IBH_DELAY	The operating time of the compressor before the indoor unit backup heater switches on	30	15	120	5	MIN.
7.3	T4_IBH_ON	The outdoor temperature for the indoor unit backup heater	-5	-15	30	1	°C
7.4	dT1_AHS_ON	Not used	-	-	-	-	-
7.5	t_AHS_DELAY	Not used	-	-	-	-	-
7.6	T4_AHS_ON	Not used	-	-	-	-	-
7.7	IBH LOCATE	IBH installation position PIPE LOOP=0; BUFFER TANK=1	0	0	0	0	°C
7.8	P_IBH1	IBH1 power supply input	0	0	20	0.5	kW
7.9	P_IBH2	Not used	0	0	20	0.5	kW
7.10	P_TBH	TBH power supply input	2	0	20	0.5	kW
8.1	T1S_H.A_H	The target outlet water temperature for space heating in Holiday Away mode	25	20	25	1	°C
8.2	T5S_H.A_DHW	The target outlet water temperature for domestic hot water heating in Holiday Away mode	25	20	25	1	°C
12.1	PREHEATING FOR FLOOR						
	T1S	The outlet water temperature setting during initial preheating of the floor	25	25	35	1	°C
	t_firstFH	Floor preheating duration	72	48	96	12	TIME

Order number	Code	Status	Default	Minimum	Maximum	Interval definition	Unit
12.2	FLOOR DRYING UP						
	HEATER TIME (t_DRYUP)	Heating days during floor drying up	8	4	15	1	DAY
	MAN. TIME (t_HIGHPEAK)	High temperature holding days during floor drying up	5	3	7	1	DAY
	TEMP. DEC. TIME (t_DRYD)	Days of temperature drop during floor drying up	5	4	15	1	DAY
	PEAK TIME (t_DRYPEAK)	Target peak temperature of the water flow during floor drying up	45	30	55	1	°C
	START TIME	Floor drying up starting time	Time: current hour (not in hour +1, in hour +2) Minute: 00	0:00	23:30	1/30	h/min
START DATE	Floor drying up starting date	The current date	1/1/2000	31/12/2099	01/01/2001	d/m/y	
13.1	AUTO RESTART COOL/HEAT MODE	Enable or disable automatic cooling/heating restart mode: 0=NO, 1=YES	1	0	1	1	/
13.2	AUTO RESTART DHW MODE	Enable or disable automatic DHW restart mode: 0=NO, 1=YES	1	0	1	1	/
14.1	POWER INPUT LIMITATION	Limitation of input current, 0=NO, 1-8=TYPE 1-8	0	0	8	1	/
15.1	ON/OFF (M1 M2)	Defines the function of the M1M2 switch: 0=heat pump remote ON/OFF, 1=TBH ON/OFF, 2 = Not used	0	0	2	1	/
15.2	SMART GRID	Enable or disable the SMART GRID: 0=NO, 1=YES	0	0	1	1	/
15.3	T1b(Tw2)	Enable or disable T1b(Tw2): 0=NO, 1=YES	0	0	1	1	/
15.4	Tbt1	Enable or disable Tbt1: 0=NO, 1=YES	0	0	1	1	/
15.5	Tbt2	Not used	0	0	1	1	/
15.6	Ta	Enable or disable Ta: 0=NO, 1=YES	0	0	1	1	/
15.7	Ta-adj	The correct Ta value on the control panel	-2	-10	10	1	°C
15.8	SOLAR INPUT	Select SOLAR INPUT: 0=NO, 1=Tsolar, 2=SL1SL2	0	0	2	1	/
15.9	F-PIPE LENGTH	Not used	0	0	1	1	/
15.10	RT/Ta_PCB	Enable or disable RT/Ta_PCB: 0=NO, 1=YES	0	0	1	1	/
15.11	PUMPI SILENT MODE	Activate or deactivate PUMPI SILENT MODE: 0=NO, 1=YES	0	0	1	1	/
16.1	PER_START	Percentage for starting several units	10	10	100	10	%
16.2	TIME_ADJUST	Set the delay to add or subtract units	5	1	60	1	MIN.

Order number	Code	Status	Default	Minimum	Maximum	Interval definition	Unit
16.3	ADDRESS RESET	Reset the address code of the unit. ("FF" is an invalid address code.) After having set the address, press "UNLOCK" to confirm.	FF	0	15	1	/
17.1	HMI SET	Select the HMI: 0=MAIN, 1=SEC.	0	0	1	1	/
17.2	HMI ADDRESS FOR BMS	Set the HMI address code for BMS	1	1	16	1	/
17.3	STOP BIT	Set the stop bit value	1	1	2	1	/

# 11 TEST MODE AND FINAL CHECKS.

The installer must check that the unit works properly after installation.

## 11.1 FINAL CHECKS.

Before switching on the appliance, read the following recommendations:

- When installation is complete and all the necessary settings have been made, close all the front panels of the unit and put the unit cover back on.
- The service panel of the electric switchgear can only be opened by an authorised electrician for maintenance.

### NOTE

During the initial operation of the unit, the required power could be higher than that indicated on the unit's data nameplate. This is caused by the compressor which needs 50 hours of operation before reaching regular operation and stable energy consumption.

## 11.2 TEST OPERATION (MANUAL).

If necessary, the installer can perform a manual test operation at any time to check proper operation of the air purge, heating, cooling, domestic hot water heating, see Chap. 10.5.11 Test operation.



# 12

## MAINTENANCE AND SERVICE.

To guarantee ideal operation of the product, a series of checks and inspections on it and its wiring must be performed at regular intervals.

Maintenance must be carried out by an authorised Immergas technician.

### DANGER

#### ELECTRICAL SPARK

- Before performing any maintenance or repairs, disconnect power to the electric control switchgear.
- Do not touch any live part for at least 10 minutes after disconnecting power.
- The compressor heater can even work in standby.
- It is prohibited to touch conductive parts.
- It is prohibited to wet the unit with water. This operation could trigger electrical discharges or fire.
- It is prohibited to leave the unit unattended if the protective casing has been removed.

The following checks must be carried out **at least once a year** by qualified Immergas personnel.

- Water pressure.
  - Check the water pressure: if below 1 bar, restore it.
- Water filter.
  - Clean the water filter.
- Water safety valve.
  - Check that the safety valve works properly by turning the black knob on the valve anti-clockwise:
    - If no noise is heard, contact an authorised Immergas technician.
    - If water continues to leak from the unit, first close the water inlet and outlet shut-off valves and then contact an authorised Immergas technician.
- Flexible hose of the pressure relief valve.
  - Check that the flexible hose of the pressure relief valve is positioned appropriately to drain water.
- Electrical switchgear of the unit.
  - Perform a thorough visual inspection of the electrical switchgear, looking for evident defects such as loose connections or faulty wiring.
  - Check that the contactors work properly using a tester. All the contacts of these contactors must be in the open position.
- Use of glycol (see Chap. 9.4.4 Anti-freeze protection of water circuit).
  - Record the concentration of glycol and the pH value in the water circuit at least once a year.
  - A pH value lower than 8.0 indicates that the inhibitor is running out and another inhibitor must be added.
  - When the pH value is lower than 7.0, it indicates glycol oxidation. The hydraulic circuit must be drained and rinsed thoroughly before causing serious damage.

Make sure that the glycol solution is disposed of in compliance with local standards and regulations.

# 13 TROUBLESHOOTING.

This section provides useful information for the diagnosis and correction of certain problems which can occur in the unit. Troubleshooting and the relative corrective actions can only be done by your local technician.

## 13.1 GENERAL GUIDELINES.

Before beginning troubleshooting, perform a thorough visual inspection of the unit, looking for evident defects such as loose connections or faulty wiring.

### WARNING

When inspecting the main compartment of the unit, always make sure that the main switch of the unit is off.

When a safety device has tripped, stop the unit and find out why the safety device tripped before resetting it. Under no such circumstances can the safety devices be bridged or modified with a different device than that set in the factory. Call your local dealer if you cannot find the cause of the problem.

If the pressure relief valve does not work properly and needs to be replaced, always reconnect the flexible hose connected to the pressure relief valve to prevent water from dripping from the unit.

## 13.2 GENERAL SYMPTOMS.

Symptom 1: the unit is on but does not heat or cool as expected.

POSSIBLE CAUSES	CORRECTIVE ACTION
The temperature setting is not correct.	Check the parameters T4HMAX, T4HMIN in heating mode. T4CMAX, T4CMIN in cool mode. T4DHWMAX, T4DHWMIN in DHW mode.
The water flow is too low.	Check that all the shut-off valves of the water circuit are in the right position. Check whether the water filter is clogged. Make sure there is no air in the water system. Check the water pressure: it should be >1 bar (with cold water). Make sure that the expansion vessel is not damaged. Check that the pressure drops of the hydraulic circuit are not too high for the pump.
The water volume in the system is too low.	Make sure that the water volume in the system is higher than the minimum required value (Chap. 9.4.2 Water volume and dimensioning of the expansion vessels).

Symptom 2: the unit is on but the compressor does not start (space heating or domestic hot water heating).

POSSIBLE CAUSES	CORRECTIVE ACTION
The unit might be working outside of its operation range (the water temperature is too low).	In case of a low-water temperature, the system uses the backup heater to reach the minimum water temperature quicker (12°C). Check that the power supply of the system backup heater is correct. Check that the thermal fuse of the system backup heater is closed. Check that the thermal protection of the system backup heater is not tripped. Check that the contactor of the system backup heater is not damaged.

Symptom 3: the pump makes noise (cavitation).

POSSIBLE CAUSES	CORRECTIVE ACTION
There is air in the system.	Purge the air.
The pressure of the water entering the pump is too low.	Check the water pressure: it should be >1 bar (the water is cold). Check that the expansion vessel is not damaged. Check that the pre-pressure adjustment of the expansion vessel is correct (Chap. 9.4.2 Water volume and dimensioning of the expansion vessels).

Symptom 4: the water pressure safety valve opens.

POSSIBLE CAUSES	CORRECTIVE ACTION
The expansion vessel is damaged.	Replace the expansion vessel.
The filling water pressure of the system is higher than 0.3 MPa.	Make sure that the filling water pressure in the system is approximately 0.10-0.20 MPa (Chap. 9.4.2 Water volume and dimensioning of the expansion vessels).

Symptom 5: lacking space heating capacity with low outdoor temperatures.

POSSIBLE CAUSES	CORRECTIVE ACTION
The backup heater is not on.	Check that the OTHER HEATING SOURCE/Indoor unit backup heater (IBH) is enabled, Chap. 10.5 Field settings. Check whether or not the thermal protection of the backup heater has tripped (Chap. Check the parts for the indoor unit backup heater (IBH)). Check whether the tank booster heater (TBH) is running. The indoor unit backup heater (IBH) and the tank booster heater (TBH) cannot run simultaneously.
An excessive capacity of the heat pump is used to heat the domestic hot water (this only applies for systems with domestic hot water storage tank).	Check that t_DHWHP_MAX and t_DHWHP_RESTRICT are configured properly. Make sure that DHW PRIORITY is disabled in the user interface. Activate T4_TBH_ON in the FOR SERVICEMAN user interface to activate the tank booster heater.

Symptom 6: heating mode cannot switch immediately to DHW mode.

POSSIBLE CAUSES	CORRECTIVE ACTION
The tank volume is too small and the position of the water temperature probe is not sufficiently high.	Set dT1S5 at the maximum value and t_DHWHP_RESTRICT at the minimum value. Set dT1SH at 2°C. Enable the TBH, and the TBH should be controlled by the unit.

Symptom 7: DHW mode cannot switch immediately to heating mode.

POSSIBLE CAUSES	CORRECTIVE ACTION
Heat exchanger for space heating not large enough.	Set t_DHWHP_MAX at the minimum value, the recommended value is 60 min. If the circulation pump outside of the unit is not controlled by the unit, try to connect it to the unit. Add a 3-way valve at the fan coil inlet to guarantee a sufficient water flow.
The space heating load is small.	Normal, heating is not required.
The disinfect function is enabled but without TBH.	Deactivate the disinfect function. Add TBH or AHS for the DHW mode.
Manually activate the FAST DHW function, after the hot water meets the requirements, the heat pump is not able to switch to air conditioning mode in time when the air conditioner is required.	Manually deactivate the FAST DHW function.
When the room temperature is low, there is not enough hot water.	Set T4DHWMIN, the recommended value is $\geq -5^{\circ}\text{C}$ . Set T4_TBH_ON, the recommended value is $\geq -5^{\circ}\text{C}$ .
DHW mode priority.	If there is an IBH connected to the unit, when the hydraulic module is faulty, the indoor unit must operate in DHW mode until the water temperature reaches the set temperature before switching to heating mode.

Symptom 8: the heat pump in DHW mode interrupts operation but the setpoint is not reached, space heating demands heat but the unit remains in DHW mode.

POSSIBLE CAUSES	CORRECTIVE ACTION
Exchange service of the tank coil not large enough.	The same solution as for Symptom 6.
TBH not available.	The heat pump remains in DHW mode until t_DHWHP_MAX or the setpoint is reached. Add TBH for the DHW mode. TBH must be controlled by the unit.

### 13.3 OPERATION PARAMETERS.

This manual is intended for the installer or service engineer controlling the operating parameters.

- On the main screen, go to MENU>OPERATION PARAMETER.
- Press OK. There are nine pages of operation parameters, as indicated below. Press ▼ and ▲ to scroll through them.
- Press ► and ◀ to check the operation parameters of the slave units in the cascade system. The code of the address in the top right corner changes from “#00” to “#01”, “#02”, etc. Therefore:

OPERATION PARAMETER	#00
ONLINE UNITS NUMBER	
OPERATE MODE	COOL
SV1 STATE	ON
SV2 STATE	OFF
SV3 STATE	OFF
PUMP_I	ON
◀ ADDRESS	1/9 ▶

OPERATION PARAMETER	#00
PUMP_O	OFF
PUMP_C	OFF
PUMP_S	OFF
PUMP_D	OFF
PIPE BACKUP HEATER	OFF
TANK BACKUP HEATER	ON
◀ ADDRESS	2/9 ▶

OPERATION PARAMETER	#00
GAS BOILER	OFF
T1 LEAVING WATER TEMP.	35°C
WATER FLOW	1.72m³/h
HEAT PUMP CAPACTIY	11.52kW
POWER CONSUM	1000kWh
Ta ROOM TEMP.	25°C
◀ ADDRESS	3/9 ▶

OPERATION PARAMETER	#00
T5 WATER TANK TEMP.	53°C
Tw2 CIRCUIT2 WATER TEMP.	35°C
TIS' C1 CLI. CURVE TEMP.	35°C
TIS2' C2 CLI. CURVE TEMP.	35°C
TW_O PLATE W-OUTLET TEMP.	35°C
TW_I PLATE W-INLET TEMP.	30°C
◀ ADDRESS	4/9 ▶

OPERATION PARAMETER	#00
Tbt1 BUFFERTANK_UP TEMP.	35°C
Tbt2 BUFFERTANK_LOW TEMP.	35°C
Tsolar	25°C
IDU SOFTWARE	01-09-2019V01
◀ ADDRESS	5/9 ▶

OPERATION PARAMETER	#00
ODU MODEL	6kW
COMP.CURRENT	12A
COMP.FREQUENCY	24Hz
COMP.RUN TIME	54 MIN
COMP.TOTAL RUN TIME	1000Hrs
EXPANSION VALVE	200P
◀ ADDRESS	6/9 ▶

OPERATION PARAMETER	#00
FAN SPEED	600R/MIN
IDU TARGET FREQUENCY	46Hz
FREQUENCY LIMITED TYPE	5
SUPPLY VOLTAGE	230V
DC GENERATRIX VOLTAGE	420V
DC GENERATRIX CURRENT	18A
◀ ADDRESS	7/9 ▶

OPERATION PARAMETER	#00
TW_O PLATE W-OUTLET TEMP.	35°C
TW_I PLATE W-INLET TEMP.	30°C
T2 PLATE F-OUT TEMP.	35°C
T2B PLATE F-IN TEMP.	35°C
Th COMP. SUCTION TEMP.	5°C
Tp COMP. DISCHARGE TEMP.	75°C
◀ ADDRESS	8/9 ▶

OPERATION PARAMETER	#00
T3 OUTDOOR EXCHANGE TEMP.	5°C
T4 OUTDOOR AIR TEMP.	5°C
TF MODULE TEMP.	55°C
P1 COMP. PRESSURE	2300kPa
ODU SOFTWARE	01-09-2018V01
HMI SOFTWARE	01-09-2018V01
◀ ADDRESS	9/9 ▶

#### NOTE

Entering the power consumption parameter is optional. Parameters not activated in the system are marked “--”.

The capacity of the heat pump is for reference only, it is not used to assess the capacity of the unit. Sensor accuracy is  $\pm 1^\circ\text{C}$ . The flow rate parameters are calculated based on the operation parameters of the pump, the deviation is different at different flow rates, the maximum deviation is 15%. The flow rate parameters are calculated based on the electric operation parameters of the pump.

The operating voltage and deviation are different.

The value displayed is 0 when voltage is lower than 198V.

### 13.4 ERROR CODES.

When a safety device trips, an error code is displayed on the control panel (which does not include an external failure).

The table below lists all of the errors and corrective actions.

Reset the safety device by switching the unit off and back on.

If this safety device reset procedure fails, contact your local dealer.

Error Code	Supervision System Error Code	Operation or protection anomaly	Cause of fault and corrective action
E0	1	Water flow fault (after E8 has been displayed 3 times).	<ol style="list-style-type: none"> <li>1. The cable circuit is short-circuited or open. Reconnect the cable properly.</li> <li>2. The water flow rate is too low.</li> <li>3. The water flow switch is faulty, the switch opens or closes continuously, replace the water flow switch.</li> </ol>
E1	2	The phase loss or the neutral cable or the live cable are connected inversely (only for three-phase unit).	<ol style="list-style-type: none"> <li>1. Check that the power cables are connected stably, to avoid the phase loss.</li> <li>2. Check the sequence of power cables, swap any sequence of two of the three power cables.</li> </ol>
E2	3	Communication fault between the control panel and the hydraulic module.	<ol style="list-style-type: none"> <li>1. The wire between the control panel and the unit is not connected. Connect the wire.</li> <li>2. The sequence of communication cables is incorrect. Reconnect the cable in the right sequence.</li> <li>3. If there is a high magnetic field or interference with high power, such as lifts, large power transformers, etc.</li> <li>4. Add a barrier to protect the unit or move the unit to another position.</li> </ol>
E3	4	Fault of the final temperature sensor of the outlet water (T1).	<ol style="list-style-type: none"> <li>1. Check the sensor resistance.</li> <li>2. The connector of sensor T1 is loose. Reconnect it.</li> <li>3. The connector of sensor T1 is wet or there is water inside. Remove the water, dry the connector. Add waterproof adhesive.</li> <li>4. Fault of sensor T1, replace it with a new sensor.</li> </ol>
E4	5	Fault of domestic hot water storage tank temperature sensor (T5)	<ol style="list-style-type: none"> <li>1. Check the sensor resistance.</li> <li>2. The connector of sensor T5 is loose. Reconnect it.</li> <li>3. The connector of sensor T5 is wet or there is water inside. Remove the water, dry the connector. Add waterproof adhesive.</li> <li>4. Fault of sensor T5, replace it with a new sensor.</li> </ol>
E5	6	Error of the refrigerant temperature sensor exiting the condenser (T3).	<ol style="list-style-type: none"> <li>1. Check the sensor resistance.</li> <li>2. The connector of sensor T3 is loose. Reconnect it.</li> <li>3. The connector of sensor T3 is wet or there is water inside. Remove the water, dry the connector. Add waterproof adhesive.</li> <li>4. Fault of sensor T3, replace it with a new sensor.</li> </ol>
E6	7	Error of room temperature sensor (T4).	<ol style="list-style-type: none"> <li>1. Check the sensor resistance.</li> <li>2. The connector of sensor T4 is loose. Reconnect it.</li> <li>3. The connector of sensor T4 is wet or there is water inside. Remove the water, dry the connector. Add waterproof adhesive.</li> <li>4. Fault of sensor T4, replace it with a new sensor.</li> </ol>
E7	8	Fault of buffer tank temperature sensor (Tbt1).	<ol style="list-style-type: none"> <li>1. Check the sensor resistance.</li> <li>2. The connector of sensor Tbt1 is loose. Reconnect it.</li> <li>3. The connector of sensor Tbt1 is wet or there is water inside. Remove the water, dry the connector. Add waterproof adhesive.</li> <li>4. Fault of sensor Tbt1, replace it with a new sensor.</li> </ol>

Error Code	Supervision System Error Code	Operation or protection anomaly	Cause of fault and corrective action
E8	9	Water flow fault.	<p>Check that all the shut-off valves of the water circuit are completely open.</p> <ol style="list-style-type: none"> <li>1. Check whether the water filter needs to be cleaned.</li> <li>2. Chap. 9.5 Filling with water.</li> <li>3. Make sure there is no air in the system (de-aeration).</li> <li>4. Check the pressure of the water. The water pressure must be &gt;1 bar.</li> <li>5. Check that the pump speed is set at the maximum speed.</li> <li>6. Make sure that the expansion vessel is not damaged.</li> <li>7. Check that the pressure drops of the hydraulic circuit are not too high for the pump (Chap. 10.4 The circulation pump).</li> <li>8. If this error occurs during defrosting (during space heating or domestic hot water heating), make sure that the power supply of the backup heater is wired correctly and that the fuses are not blown.</li> <li>9. Check that the fuse of the pump and the fuse of the PCB are not blown.</li> </ol>
E9	10	Error of compressor intake temperature sensor (Th).	<ol style="list-style-type: none"> <li>1. Check the sensor resistance.</li> <li>2. The connector of sensor Th is loose. Reconnect it.</li> <li>3. The connector of sensor Th is wet or there is water inside. Remove the water, dry the connector. Add waterproof adhesive.</li> <li>4. Fault of sensor Th, replace it with a new sensor.</li> </ol>
EA	11	Error of compressor drain temperature sensor (Tp).	<ol style="list-style-type: none"> <li>1. Check the sensor resistance.</li> <li>2. The connector of sensor Tp is loose. Reconnect it.</li> <li>3. The connector of sensor Tp is wet or there is water inside. Remove the water, dry the connector. Add waterproof adhesive.</li> <li>4. Fault of sensor Tp, replace it with a new sensor.</li> </ol>
Eb	12	Error of solar panel temperature sensor (Tsolar).	<ol style="list-style-type: none"> <li>1. Check the sensor resistance.</li> <li>2. The connector of sensor Tsolar is loose. Reconnect it.</li> <li>3. The connector of sensor Tsolar is wet or there is water inside. Remove the water, dry the connector. Add waterproof adhesive.</li> <li>4. Fault of sensor Tsolar, replace it with a new sensor.</li> </ol>
EC	13	Error of low temperature sensor (Tbt2) of the thermostat manifold.	<ol style="list-style-type: none"> <li>1. Check the sensor resistance.</li> <li>2. The connector of sensor Tbt2 is loose. Reconnect it.</li> <li>3. The connector of sensor Tbt2 is wet or there is water inside. Remove the water, dry the connector. Add waterproof adhesive.</li> <li>4. Fault of sensor Tbt2, replace it with a new sensor.</li> </ol>
Ed	14	Error of inlet water temperature sensor (Tw_in) of plate heat exchanger.	<ol style="list-style-type: none"> <li>1. Check the sensor resistance.</li> <li>2. The connector of sensor Tw_in is loose. Reconnect it.</li> <li>3. The connector of sensor Tw_in is wet or there is water inside. Remove the water, dry the connector. Add waterproof adhesive.</li> <li>4. Fault of sensor Tw_in, replace it with a new sensor.</li> </ol>
EE	15	EEPROM fault of the main control board of hydraulic module.	<ol style="list-style-type: none"> <li>1. The EEprom parameter is in error, rewrite the EEprom data.</li> <li>2. The EEprom component is damaged, replace the EEprom component.</li> <li>3. The main control board of the hydraulic module is damaged, replace it with a new PCB.</li> </ol>
EP	19	Leakage fault on tank booster heater (TBH).	Check device connected to the TBH outputs.

Error Code	Supervision System Error Code	Operation or protection anomaly	Cause of fault and corrective action
P0	20	Low pressure protection switch.	<ol style="list-style-type: none"> <li>1. The system is without refrigerant volume. Charge the refrigerant at the right volume.</li> <li>2. In heating mode or in DHW mode, the external heat exchanger is dirty or something is blocked on the surface. Clean the external heat exchanger or remove the obstruction.</li> <li>3. The water flow is too low in cooling mode. Increase the water flow.</li> <li>4. The electric expansion valve is blocked or the winding connector is loose. Touch the body of the valve and connect/disconnect the connector several times to make sure that the valve works properly.</li> </ol>
P1	21	High pressure protection switch.	<p>Heating mode, DHW mode:</p> <ol style="list-style-type: none"> <li>1. The water flow is low; the temperature of the water is high, if there is air in the water system. Release the air.</li> <li>2. The water pressure is lower than 0.1 MPa, load the water to leave the pressure in the range 0.15-0.2 MPa.</li> <li>3. Refrigerant volume overload. Recharge the refrigerant at the right volume.</li> <li>4. The electric expansion valve is blocked or the winding connector is loose. Touch the body of the valve and connect/disconnect the connector several times to make sure that the valve works properly. Also install the winding in the right position. DHW mode: The storage tank coil is small.</li> </ol> <p>Cooling mode:</p> <ol style="list-style-type: none"> <li>1. The protection of the heat exchanger has not been removed. Remove the protection.</li> <li>2. The heat exchanger is dirty or something is blocked on the surface. Clean the heat exchanger or remove the obstruction.</li> </ol>
P3	23	Protection against compressor overcurrent.	<ol style="list-style-type: none"> <li>1. The same reason as for P1.</li> <li>2. The supply voltage of the unit is low, increase the supply voltage to the required range.</li> </ol>
P4	24	Protection against flow temperature of the compressor too high	<ol style="list-style-type: none"> <li>1. The same reason as for P1.</li> <li>2. The system is without refrigerant volume. Charge the refrigerant at the right volume.</li> <li>3. The sensor Tw_out temp. is loose. Reconnect it.</li> <li>4. The sensor T1 temp. is loose. Reconnect it.</li> <li>5. The sensor T5 temp. is loose. Reconnect it.</li> </ol>
P5	25	High temperature difference between water inlet and water outlet of the plate heat exchanger. (Tw_out-Tw_in)	<ol style="list-style-type: none"> <li>1. Check that all the shut-off valves of the water circuit are completely open.</li> <li>2. Check whether the water filter needs to be cleaned.</li> <li>3. Chap. 9.5 Filling with water.</li> <li>4. Make sure there is no air in the system (de-aeration).</li> <li>5. Check the pressure of the water. The water pressure must be &gt;1 bar (with cold water).</li> <li>6. Check that the pump speed is set at the maximum speed.</li> <li>7. Make sure that the expansion vessel is not damaged.</li> <li>8. Check that the pressure drops of the hydraulic system are not too high for the pump (Chap. 10.4 The circulation pump).</li> </ol>



Error Code	Supervision System Error Code	Operation or protection anomaly	Cause of fault and corrective action
P6	26	Inverter module protection.	<ol style="list-style-type: none"> <li>1. The supply voltage of the unit is low, increase the supply voltage to the required range.</li> <li>2. The space between the units is too narrow for the thermal exchange. Increase the space between the units.</li> <li>3. The heat exchanger is dirty or something is blocked on the surface. Clean the heat exchanger or remove the obstruction.</li> <li>4. The fan does not work. The motor of the fan or the fan is damaged, replace it with a new fan or a new motor.</li> <li>5. Refrigerant volume overload. Recharge the refrigerant at the right volume.</li> <li>6. The water flow rate is low, there is air in the system, or the pump head is not sufficient. Release the air and select the pump again.</li> <li>7. The outlet water temperature sensor is loose or damaged, reconnect it or replace it with a new one.</li> <li>8. The storage tank coil is small.</li> <li>9. The wiring of the module or the screws are loose. Reconnect the wires and screws. The thermally conductive adhesive is dry or shifted. Add some thermally conductive adhesive.</li> <li>10. The connection of the cables is loose or failed. Reconnect the cable.</li> <li>11. The drive board is faulty, replace it with a new one.</li> <li>12. If it already has been confirmed that the control system has no problems, then the compressor is faulty. Replace it with a new compressor.</li> </ol>
P9	29	Fan protection.	Check the condition of the fan and of the fan motor.
Pb	31	Antifreeze protection.	The unit automatically returns to normal operation.
Pd	33	High temperature protection of the outlet temperature of the refrigerant in the condenser.	<ol style="list-style-type: none"> <li>1. The protection of the heat exchanger has not been removed. Remove the protection.</li> <li>2. The heat exchanger is dirty or something is blocked on the surface. Clean the heat exchanger or remove the obstruction.</li> <li>3. There is not enough space around the unit for thermal exchange.</li> <li>4. The fan motor is damaged, replace it with a new one.</li> </ol>
PP	38	The inlet water temperature is higher than the water outlet in heating mode. ( $T_{w\_in} > T_{w\_out}$ )	<ol style="list-style-type: none"> <li>1. Check the resistance of the two sensors.</li> <li>2. Check the two positions of the sensors.</li> <li>3. The connector of the cable of the water inlet/outlet sensor is loose. Reconnect it.</li> <li>4. The water inlet/outlet sensor (<math>T_{w\_in}/T_{w\_out}</math>) is damaged. Replace it with a new sensor.</li> <li>5. The four-way valve is blocked. Restart the unit to allow the valve to change direction.</li> <li>6. The four-way valve is damaged, replace it with a new valve.</li> </ol>
H0	39	Communication fault between the main control board of the hydraulic module and the main control board PCB B.	<ol style="list-style-type: none"> <li>1. The cable does not connect the main control board PCB B and the main control board of the hydraulic module. Connect the cable.</li> <li>2. The sequence of communication cables is incorrect. Reconnect the cable in the right sequence.</li> <li>3. If there is a high magnetic field or interference due to high power, such as lifts, large power transformers, etc. Add a barrier to protect the unit or move the unit to another position.</li> </ol>
H1	40	Communication error between the inverter module PCB A and the main control board PCB B.	<ol style="list-style-type: none"> <li>1. Check whether the two boards PCB A (inverter module) and PCB B (control board) are powered. Check whether the indicator light on the printed circuit of the inverter is on or off. If the light is off, reconnect the power cable.</li> <li>2. If the light is on, check the wiring connection between the PCB of the inverter module and the PCB of the main control board. If wiring is loose or damaged, reconnect the wiring or change with new wiring.</li> <li>3. Replace the main board (PCB B) and then the inverter module (PCB A).</li> </ol>



Error Code	Supervision System Error Code	Operation or protection anomaly	Cause of fault and corrective action
H2	41	Fault of outlet temperature sensor (T2) of refrigerant from the plate heat exchanger (liquid pipe).	<ol style="list-style-type: none"> <li>1. Check the sensor resistance.</li> <li>2. The connector of sensor T2 is loose. Reconnect it.</li> <li>3. The connector of sensor T2 is wet or there is water inside. Remove the water and dry the connector. Add waterproof adhesive.</li> <li>4. Fault of sensor T2, replace it with a new sensor.</li> </ol>
H3	42	Fault of outlet temperature sensor (T2B) of refrigerant from the plate heat exchanger (gas pipe).	<ol style="list-style-type: none"> <li>1. Check the sensor resistance.</li> <li>2. The connector of sensor T2B is loose. Reconnect it.</li> <li>3. The connector of sensor T2B is wet or there is water inside. Remove the water and dry the connector. Add waterproof adhesive.</li> <li>4. Fault of sensor T2B, replace it with a new sensor.</li> </ol>
H4	43	Protection for three times P6 (L0/L1)	The total number of times in which L0 and L1 appear in an hour is equal to three. See L0 and L1 for the fault management methods.
H5	44	Fault of room temperature sensor (Ta).	<ol style="list-style-type: none"> <li>1. Check the sensor resistance.</li> <li>2. The sensor Ta is in the control panel.</li> <li>3. Fault of sensor Ta, replace with a new sensor or switch to a new panel, or reset Ta, connect a new Ta from the hydraulic module PCB.</li> </ol>
H6	45	Fault of fan motor.	<ol style="list-style-type: none"> <li>1. Strong wind towards the fan, turn the fan in the opposite direction. Change the direction of the unit or create a guard to prevent the wind from going towards the fan.</li> <li>2. The fan motor is damaged, replace it with a new motor.</li> </ol>
H7	46	Main circuit voltage protection fault.	<ol style="list-style-type: none"> <li>1. If the power supply input is within the available range.</li> <li>2. Switch on and off several times quickly and in a short amount of time. Keep the unit off for more than 3 minutes after ignition.</li> <li>3. The part of the circuit of the main control board is faulty. Replace with a new main PCB.</li> </ol>
H8	47	Fault of pressure sensor.	<ol style="list-style-type: none"> <li>1. The connector of the pressure sensor is loose, reconnect it.</li> <li>2. Fault of pressure sensor. Replace it with a new sensor.</li> </ol>
H9	48	Fault of zone 2 water temperature sensor (Tw2).	<ol style="list-style-type: none"> <li>1. Check the sensor resistance.</li> <li>2. The connector of sensor Tw2 is loose. Reconnect it.</li> <li>3. The connector of sensor Tw2 is wet or there is water inside. Remove the water, dry the connector. Add waterproof adhesive.</li> <li>4. Fault of sensor Tw2, replace it with a new sensor.</li> </ol>
HA	49	Fault of outlet water temperature sensor (Tw_out).	<ol style="list-style-type: none"> <li>1. Check the sensor resistance.</li> <li>2. The connector of sensor Tw_out is loose. Reconnect it.</li> <li>3. The connector of sensor Tw_out is wet or there is water inside. Remove the water, dry the connector. Add waterproof adhesive.</li> <li>4. Fault of sensor Tw_out, replace it with a new sensor.</li> </ol>
Hb	50	Protection "PP" three times and Tw_out < 7°C	The same applies for "PP"

Error Code	Supervision System Error Code	Operation or protection anomaly	Cause of fault and corrective action
Hd	52	Communication fault between hydraulic module in parallel.	<ol style="list-style-type: none"> <li>1. The signal wires of the slave units and of the master unit are not connected effectively. After having checked that all the signal wires are properly connected, and having made sure that there is no strong electricity or strong magnetic interferences, switch the unit back on.</li> <li>2. There are two or more outdoor units connected to the control panel. After having removed the extra control panel and having kept only the control panel of the master unit, switch the unit back on.</li> <li>3. The ignition interval between the master unit and the slave unit is longer than 2 minutes. After having made sure that the interval between ignition of all the master units and slave units is less than 2 minutes, switch the unit back on.</li> <li>4. The addresses of the master units and of the slave units are repeated; pressing the key SW2 on the main board of the slave units once, the address code of the slave unit will be displayed (Normally address code, one of 1,2,3 ... 15 will be displayed on the main board), check whether it is a duplicate of the address. If there is a duplicated address code, after having switched the system off, set S4-1 at ON on the main board of the master unit or on the main board of the slave unit displaying the error "Hd" (refer to Chap. 10.1.1 Setting of the function). Switch all the units back on for 5 minutes without error "Hd", switch back off and set S4-1 at OFF. The system is reset.</li> </ol>
HE	53	Communication error between main board and thermostat transfer board.	The control board RT/Ta PCB is set to be valid on the control panel but the thermostat transfer board is not connected or communication between the thermostat transfer board and the main board is not actually connected. If the transfer board of the thermostat is not necessary, set RT/Ta PCB at not valid. If the transfer board of the thermostat is necessary, connect it to the main board and make sure that the communication wire is properly connected and that there are no strong electricity or strong magnetic interferences.
HF	54	EEPROM fault of the inverter module board.	<ol style="list-style-type: none"> <li>1. The EEPROM parameter is in error, rewrite the EEPROM data.</li> <li>2. The EEPROM component is damaged, replace the EEPROM component.</li> <li>3. The module board of the inverter is damaged, replace it with a new PCB.</li> </ol>
HH	55	H6 appeared 10 times in 2 hours.	See H6.
HP	57	Low pressure protection in cooling $P_e < 0.6$ occurred 3 times in one hour.	See P0.
C7	65	Temperature of transducer module too high.	<ol style="list-style-type: none"> <li>1. The supply voltage of the unit is low, increase the supply voltage to the required range.</li> <li>2. The space between the units is too narrow for the thermal exchange. Increase the space between the units.</li> <li>3. The heat exchanger is dirty or something is blocked on the surface. Clean the heat exchanger or remove the obstruction.</li> <li>4. The fan does not work. The motor of the fan or the fan is damaged, replace it with a new fan or a new motor.</li> <li>5. The water flow rate is low, there is air in the system, or the pump head is not sufficient. Release the air and select the pump again.</li> <li>6. The outlet water temperature sensor is loose or damaged; reconnect it or replace it with a new one.</li> </ol>

Error Code	Supervision System Error Code	Operation or protection anomaly	Cause of fault and corrective action
F1	116	Low voltage protection on DC bus.	<ol style="list-style-type: none"> <li>1. Check power supply.</li> <li>2. If the power supply is OK, check whether the LED light is OK, check whether PN voltage is 380V, the problem usually comes from the main board. Furthermore, if the light is OFF, disconnect power, check the IGBT, check the diodes. If voltage is not correct or the inverter board is damaged, change it.</li> <li>3. If there is no problem with IGBT, it means that there are problems on the board of the inverter. Check the rectifier jumper. (Same method as IGBT: disconnect power, check whether or not the diodes are damaged).</li> <li>4. Usually, if F1 is displayed when the compressor is started, it likely depends on the main board. If F1 appears when the fan is started, it could be due to the board of the inverter.</li> </ol>
L0	134	Compressor inverter module fault.	<ol style="list-style-type: none"> <li>1. Check the pressure of the heat pump system.</li> <li>2. Check the phase resistance of the compressor.</li> <li>3. Check the connection sequence of the power line U, V, W between the inverter board and the compressor.</li> <li>4. Check the connection of the power line L1, L2, L3 between the inverter board and the filter board.</li> <li>5. Check the board of the inverter.</li> </ol>
L1	135	Low voltage protection on DC bus.	
L2	136	High voltage protection on DC bus.	
L4	138	MCE operation anomaly.	
L5	139	Zero speed protection.	
L7	141	Phase sequence fault (only three-phase models).	
L8	142	Frequency variation of compressor higher than 15Hz within 1 second.	
L9	143	The actual frequency of the compressor differs from the target frequency by over 15Hz.	

# 14 TECHNICAL SPECIFICATIONS.

## 14.1 GENERAL.

### Models 4-16 kW.

	Single-phase	Single-phase	Single-phase	Three phase
	4/6 kW	8 kW	12/14/16 kW	12/14/16 kW
Nominal capacity	Chap.technical data			
Dimensions HxWxD	712x1295x429 mm	865x1385x526 mm	865x1385x526 mm	865x1385x526 mm
Dimensions of the box HxWxD	885x1375x475 mm	1035x1465x560 mm	1035x1465x560 mm	1035x1465x560 mm
Minimum flow rate	0.40 m <sup>3</sup> /h	0.40 m <sup>3</sup> /h	0.70 m <sup>3</sup> /h	
Maximum flow rate	4 kW: 0.90 m <sup>3</sup> /h	1.65 m <sup>3</sup> /h	12 kW: 2.50 m <sup>3</sup> /h	
	6 kW: 1.25 m <sup>3</sup> /h		14 kW: 2.75 m <sup>3</sup> /h	
			16 kW: 3.00 m <sup>3</sup> /h	
<b>Weight</b>				
Net weight	86 kg	105 kg	129 kg	144 kg
Gross weight	109 kg	132 kg	155 kg	172 kg
<b>Connections</b>				
Water inlet/outlet	G1" BSP	G5/4" BSP	G5/4" BSP	G5/4" BSP
Water drain	Fitting for flexible hose			
<b>Expansion vessel</b>				
Volume	8 L			
Maximum working pressure (MWP)	8 bar			
<b>Pump</b>				
Type	Water-cooled			
Speed number	Variable speed			
Internal water volume	3.2 L	3.2 L	2.0 L	2.0 L
Water circuit of the pressure relief valve	3 bar			
<b>Operation range - water side</b>				
Central heating	+12 ~ +65°C			
Cooling	+5 ~ +25°C			
<b>Operation range - air side</b>				
Central heating	-25 ~ +35°C			
Cooling	-5 ~ +43°C			
Domestic hot water with heat pump	-25 ~ +43°C			

### Models 18-30 kW.

	Three phase			
	18 kW	22 kW	26 kW	30 kW
Nominal capacity	Chap.technical data			
Dimensions HxWxD	1129x1558x528 mm			
Dimensions of the box HxWxD	1220x1735x565 mm			
Heat exchanger	Plate heat exchanger			
Internal water volume	3.5 L			
Safety valve	0.3 Mpa			
Filter mesh	60			
Minimum flow rate of water (flow switch)	27 L/min			
<b>Weight</b>				
Net weight	177 kg			
Gross weight	206 kg			
<b>Connections</b>				
Water inlet/outlet	G5/4" BSP			
Water drain	Fitting for flexible hose			
<b>Expansion vessel</b>				
Volume	8 L			
Maximum working pressure	1.0 Mpa			
Pre-charged pressure	0.1 Mpa			
<b>Pump</b>				
Type	Fixed speed pump			
Maximum lift of pump	12 m			
Power input	262 W			
<b>Operation range - water side</b>				
Central heating	+5 ~ +60°C			
Cooling	+5 ~ +25°C			
<b>Operation range - air side</b>				
Central heating	-25 ~ +35°C			
Cooling	-5 ~ +46°C			
Domestic hot water with heat pump	-25 ~ +43°C			

### 14.2 ELECTRICAL TECHNICAL SPECIFICATIONS.

#### Models 4-16 kW.

	4 kW	6 kW	8 kW	12 kW	14 kW	16 kW	12 kW T	14 kW T	16 kW T
Power supply	220-240V ~ 50Hz						380-415V 3N ~ 50Hz		
Rated input	2.3 kW	2.7 kW	3.4 kW	5.5 kW	5.8 kW	6.2 kW	5.5 kW	5.8 kW	6.2 kW
Rated operating current	12 A	14 A	16 A	25 A	26 A	27 A	10 A	11 A	12 A

#### Models 18-30 kW.

	18 kW Three phase	22 kW Three phase	26 kW Three phase	30 kW Three phase
Power supply	380-415V 3N ~ 50Hz			
Rated input	10.6 kW	12.5 kW	13.8 kW	14.5 kW
Rated operating current	16.8 A	19.6 A	21.6 A	22.8 A

# 15 INFORMATION ON MAINTENANCE.

## 1) Checks in the area.

Before starting work on systems containing flammable refrigerants, safety checks must be performed to guarantee that the risk of flammability is reduced to a minimum. Before performing repairs on chilling systems, follow the precautions below.

## 2) Work procedure.

The jobs must be carried out according to a consolidated safety procedure to reduce the risk of refrigerant or flammable vapour leaks during work to a minimum.

## 3) Work area.

All maintenance personnel and anyone else working in the involved area must be informed as to the nature of the work carried out. Avoid working in confined spaces. The area in the immediate vicinity of the work field must be appropriately delimited. Make sure that there are safety conditions within the area to prevent the risk of refrigerant leaks.

## 4) Refrigerant leak check.

The area must be checked with an adequate refrigerant detector before and during the jobs, to guarantee that the technician is aware of the presence of potentially flammable atmospheres. Make sure that the leak detector is suitable to be used with flammable refrigerants, namely without electric discharges, appropriately sealed or inherently safe.

## 5) Presence of a fire extinguisher.

If hot work needs to be done on the chilling system or on related parts, adequate firefighting devices must be available. Check that there is a dry fire extinguisher or a CO<sub>2</sub> fire extinguisher adjacent to the recharge area.

## 6) No source of ignition.

No one carrying out work in relation to a chilling system that entails exposure of pipes that contain or have contained flammable refrigerant must use sources of ignition implicating the risk of fire or explosion. All possible sources of ignition, including cigarette embers, must be kept sufficiently far from the place of installation, repair, removal and disposal, during which the flammable refrigerant could be released into the surrounding area. Before starting the work, the area around the appliance must be monitored to make sure there are no flammability hazards or ignition risks. "NO SMOKING" signs must be applied.

## 7) Ventilated area.

Make sure that the area is outdoors or appropriately ventilated before entering it or performing hot work. A certain ventilation level must also be guaranteed while carrying out the work. Ventilation must safely release the dispersed refrigerant and preferably eject it into the outside atmosphere.

## 8) Checks on the chilling equipment.

When replacing electric components, these must be suitable for the purpose for which they are used and comply with the correct specifications. The manufacturer's guidelines for maintenance and service must be complied with that all times. Should any doubts arise, contact the Authorised Immergas Technical Service for assistance. The following controls must be applied to systems that make use of flammable refrigerants:

- The recharging amount depends on the size of the room where the appliances containing the refrigerant are installed;
- Ventilation devices must run regularly and the ejection routes must not be obstructed;
- Illegible markings or writings must be corrected.
- Chilling lines or refrigeration components must be installed in a position where they are unlikely to be exposed to any substance that can corrode components containing refrigerants, unless the components themselves are made of materials inherently resistant to corrosion or have been adequately protected against corrosion.

## 9) Checks on electrical devices.

Repair and maintenance operations on electric components must include preventive safety checks and inspection procedures of the components. If a fault occurs that could jeopardise safety, the circuit must not be powered until the issue has been resolved in a satisfactory way. If it is not possible to immediately eliminate the fault, but the system needs to keep running, a temporary solution must be found. This must be communicated to the owner of the equipment so that all parties are informed thereof.

The initial safety checks include making sure:

- That the capacitors are discharged: this is essential to avoid the possibility of electrical discharges;
- That there are no live components or cables during charging, recovery or purging of the circuit;
- That a compliant earthing system is in place.

#### 10) Repair of sealed components.

a) During repairs of sealed components, all power supplies must be disconnected from the appliance in operation before removing the sealed covers, etc. If it is absolutely necessary that the appliance be energised during maintenance, a permanently operated leak detection device must be used, at the most critical point, to prevent a potentially hazardous situation.

b) Special attention must be paid to the following to make sure that, while working on electric components, the enclosure is not changed in such a way as to alter the protection level. This includes damage to cables, an excessive number of connections, terminals non-conforming to the original specifications, damage to gaskets, incorrect assembly of cable glands, etc.

- Check that the appliance is installed appropriately.
- Make sure that the gaskets or sealing materials are not degraded to such a point that flammable atmospheres may enter. The spare parts must comply with the specifications of the manufacturer.

#### **NOTE**

The use of silicone sealant could inhibit the effectiveness of some types of leak detection equipment. Inherently safe components must not be isolated before working on them.

#### 11) Repair of inherently safe components.

Do not apply permanent inductive or capacitive loads to the circuit without first having checked that they do not exceed the voltage and current allowed for the instruments in use. Inherently safe components are the only ones on which it is possible to work when live in the presence of a flammable atmosphere. The test equipment must be correctly classified. Only replace the components with others indicated by the manufacturer. The use of other components could trigger refrigerant flammability following a leak into the atmosphere.

#### 12) Wiring.

Check that wiring is not subject to wear, corrosion, excessive pressure, vibrations, sharp edges or other adverse environmental effects. The check must also take into consideration the consequences of aging or of continuous vibrations coming from sources such as compressors or fans.

#### 13) Detection of flammable refrigerants.

Under no circumstances must potential sources of ignition be used to look for or detect refrigerant leaks. Halide torches (or any other detector that uses naked flames) must not be used.

#### 14) Leak detection methods.

The following leak detection methods are deemed acceptable for systems containing flammable refrigerants. Electronic leak detectors must be used to detect flammable refrigerants, but their sensitivity might not be adequate or require recalibration. (The detection device must be calibrated in an area free of refrigerants). Make sure that the detector is not a potential source of ignition and that it is suitable for the refrigerant. The leak detection appliance must be set at an LFL percentage of the refrigerant and calibrated for the refrigerant used; the appropriate percentage of gas is confirmed (25% at maximum). Leak detection fluids can be used with the majority of refrigerants, but detergents containing chlorine must not be used as this element can react with the refrigerant and corrode the copper pipes. If there is a suspected leak, all naked flames must be removed or put out.

#### 15) Removal and discharge.

When interacting on the refrigerant circuit to perform repairs or for any other purpose, conventional procedures must be followed. It will be important to abide by consolidated practice as flammability is a very important factor to be taken into consideration. The following procedure must be complied with:

- Remove the refrigerant;
- Purge the circuit with inert gas;
- Discharge;
- Purge again with inert gas;
- Restore the circuit by cutting or performing a brazing intervention.

The refrigerant charge must be recovered in appropriate recovery cylinders. The circuit must be washed with nitrogen to remove impurities from the appliance. This process might need to be repeated several times.

Compressed air or oxygen must not be used for this activity.

Make sure that the vent of the vacuum pump is not exposed to triggering sources with a simultaneous ventilation source.

#### 16) Charging procedure.

In addition to conventional charging procedures, the following requirements must be complied with:

- Make sure that different refrigerant contaminations do not occur when using recharging equipment. The tubes or pipes must be as short as possible to minimise the amount of refrigerant therein.
- The cylinders must be kept upright.
- Make sure that the chilling system is earthed before charging the system with refrigerant.
- Label the circuit when the charge is complete (unless this has already been done).
- Pay the utmost attention not to subsequently fill the chilling circuit.
- Before recharging the circuit, it must undergo a pressurised leak test with nitrogen.

#### 17) Deactivation.

Before performing this operation, the technician must have extensive knowledge of the appliance and all its details. It is good practice that the refrigerant be recovered correctly. Before performing the intervention, an oil and refrigerant sample must be withdrawn.

If an analysis needs to be performed before recovering the refrigerant, power must be available.

- a) Become acquainted with the appliance and its operation.
- b) Disconnect power to the product.
- c) Before starting the activity, proceed as follows:
  - Ascertain, where necessary, the availability of mechanical equipment to handle the refrigerant cylinders.
  - Check that personal protective equipment is available and used correctly.
  - Make sure that the recovery operation is supervised at all times by a skilled person.
  - The equipment and the recovery cylinders comply with current regulations.
- d) Empty the chilling circuit by means of the specific service ports.
- e) If it is not possible to discharge the circuit by means of the specific service ports, make a “manifold” so that the refrigerant can be removed from other points of the system.
- f) Make sure that the cylinder is placed on the scale before proceeding with recovery.
- g) Start the recovery machine and follow the instructions given by the manufacturer.
- h) Do not overfill the cylinders. (Do not exceed 80% of the charge volume of the liquid).
- i) Do not exceed the maximum working pressure of the cylinder, not even temporarily.
- j) When the cylinders have been filled to the maximum capacity and the intervention has been completed, make sure that these and the equipment are immediately removed from the area and that all shut-off valves on the equipment are closed.
- k) The recovered refrigerant cannot be recharged into another chilling system unless it has been regenerated and controlled.

#### 18) Labelling.

The appliance must be labelled with an indication that it has been decommissioned and the refrigerant emptied. The label must be dated and signed. Make sure that there are labels on the appliance indicating that it contains flammable refrigerant.



#### 19) Recovery.

When refrigerant is removed from a system, both for maintenance operations and deactivation, good practice is recommended to remove the refrigerant correctly.

When the refrigerant is transferred to cylinders, make sure that only adequate cylinders for recovery of refrigerant are used. Make sure that a proportionate number of cylinders is available for storage of the total charge of the system. All the cylinders to be used are specifically dedicated for the recovered refrigerant and labelled accordingly (namely they are specific cylinders for refrigerant recovery). The cylinders must have a pressure relief valve and relative shut-off cocks in good working conditions.

The recovery cylinders must be in vacuum and, if possible, cooled before the recovery operation.

The recovery equipment must be in good working order with relative instructions close at hand and it must also be suitable for the recovery of flammable refrigerants. Lastly, a series of calibrated scales must be available and in good working order. The flexible hoses must be complete with shut-off valves without leaks and in good conditions. Before using the recovery instrument, check that it is in satisfactory operating conditions, that maintenance has been performed correctly and all the associated electric components have been sealed to avoid an accidental ignition in case of a refrigerant leak. Contact the manufacturer in case of doubts.

The recovered refrigerant must be returned to the refrigerant supplier in the appropriate recovery cylinder and the relative waste transfer note must be drafted. Do not mix refrigerants in recovery units and above all not inside the cylinders. Should it be necessary to remove compressors or oil for compressors, make sure that they have been emptied sufficiently to guarantee that no flammable refrigerant remains inside the lubricant. The emptying procedure must be carried out before returning the compressor to the supplier. To speed up this operation, only electrical heating should be used on the body of the compressor. When oil is discharged from a system, the operation must be performed safely.

#### 20) Transport, marking and storage of the appliances.

Transportation of equipment containing flammable refrigerants (Conformity with transport standards).

Marking of equipment with signs (Conformity with local standards).

Disposal of equipment using flammable refrigerants (Conformity with national standards).

Storage of equipment/appliances.

The appliances must be stored in compliance with the instructions of the manufacturer.

Storage of packaged equipment (unsold).

The protection of the storage packaging must be built in such a way that any mechanical damage to the equipment inside the packaging does not cause a leak of the refrigerant charge.

The maximum number of appliances that can be stored together will be determined by local regulations.

15.1 ANNEXES - REFRIGERANT CYCLE.

ANNEX A: Refrigerant cycle Units 4-16 kW.

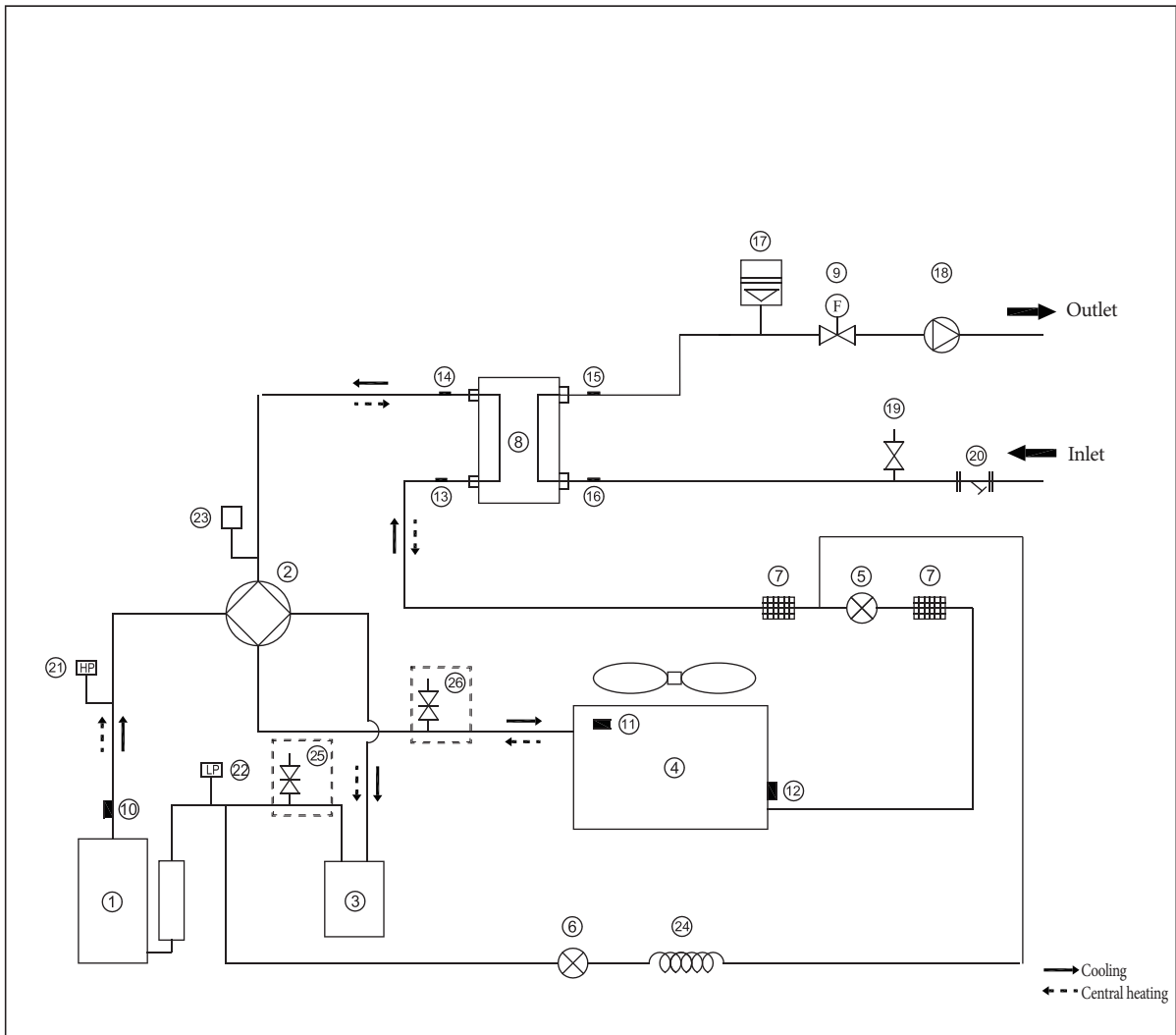

Code	Description	Code	Description
1	Compressor	14	Refrigerant outlet temperature sensor (gas pipe)
2	4-way valve	15	Water outlet temperature sensor
3	Gas- liquid separator	16	Water inlet temperature sensor
4	Air side heat exchanger	17	Expansion vessel
5	Electronic expansion valve	18	Circulation pump
6	One-way magnetic valve	19	Pressure relief valve
7	Filter	20	Y-shaped filter
8	Water side heat exchanger (Plate heat exchanger)	21	High pressure switch
9	Flow switch	22	Low pressure switch
10	Discharge gas sensor	23	Pressure sensor
11	Outdoor temperature sensor	24	Capillary
12	Evaporation sensor in heating (Condenser sensor in cooling)	25	Needle valve for recharging refrigerant gas (ONLY ON Unit 4 - 6 kW)
13	Refrigerant inlet temperature sensor (liquid pipe)	26 *	Needle valve for recharging refrigerant gas (ONLY ON Unit 8 - 16 kW)

(\*) = Make a heating demand to complete the recharge of the refrigerant gas.

ANNEX B: Refrigerant cycle Units 18-30 kW.

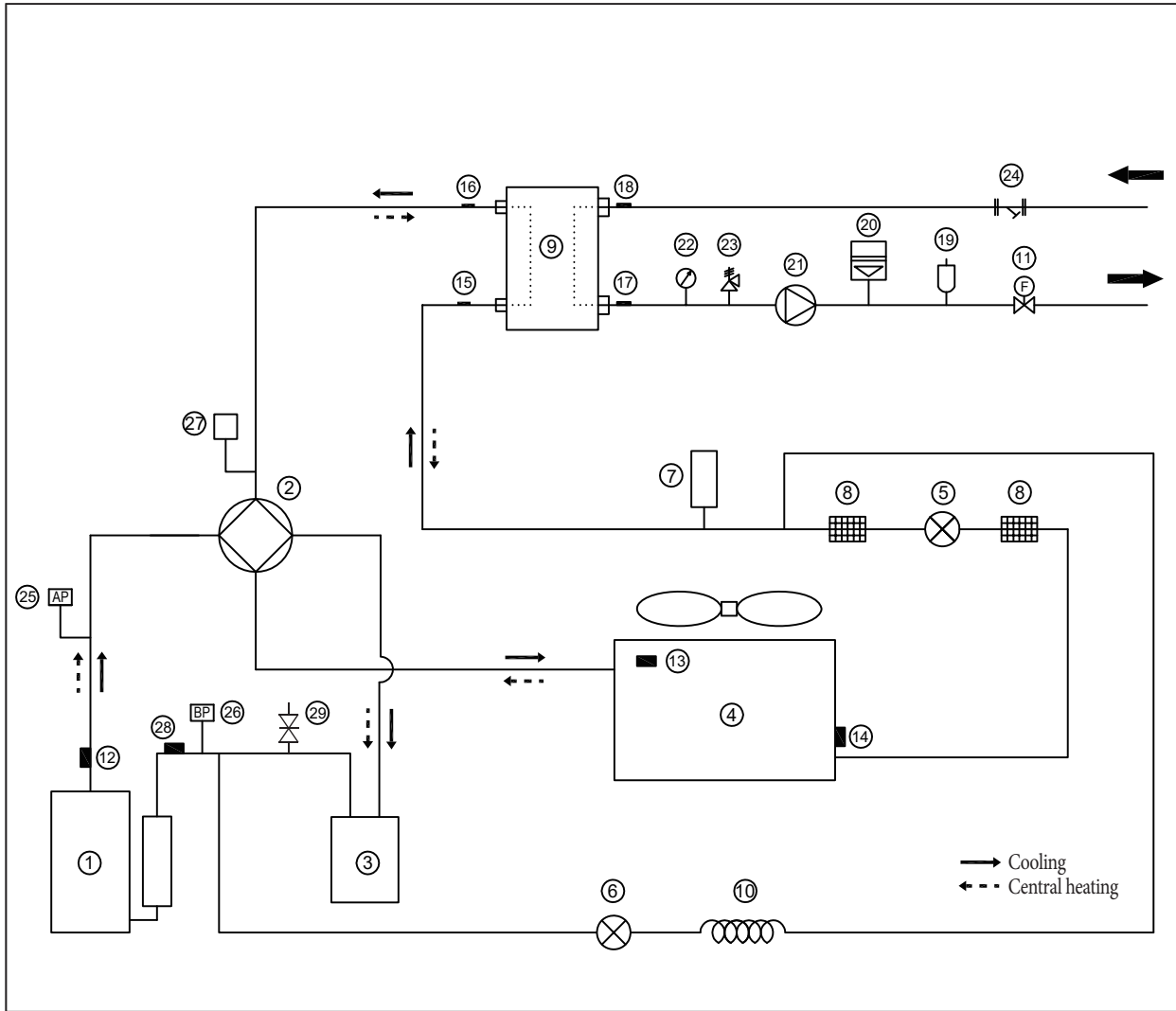

Code	Description	Code	Description
1	Compressor	16	Refrigerant outlet temperature sensor (gas pipe)
2	4-way valve	17	Water outlet temperature sensor
3	Gas- liquid separator	18	Water inlet temperature sensor
4	Air side heat exchanger	19	Automatic air purge valve
5	Electronic expansion valve	20	Expansion vessel
6	One-way magnetic valve	21	Circulation pump
7	Tank	22	Pressure gauge
8	Filter	23	Safety valve
9	Water side heat exchanger (Plate heat exchanger)	24	Y-shaped filter
10	Capillary	25	High pressure switch
11	Flow switch	26	Low pressure switch
12	Discharge gas sensor	27	Pressure valve
13	Outdoor temperature sensor	28	Intake temperature sensor
14	Evaporation sensor in heating (Condenser sensor in cooling)	29	Needle valve for recharging refrigerant gas
15	Refrigerant inlet temperature sensor (liquid pipe)		



This instruction booklet  
is made of ecological paper

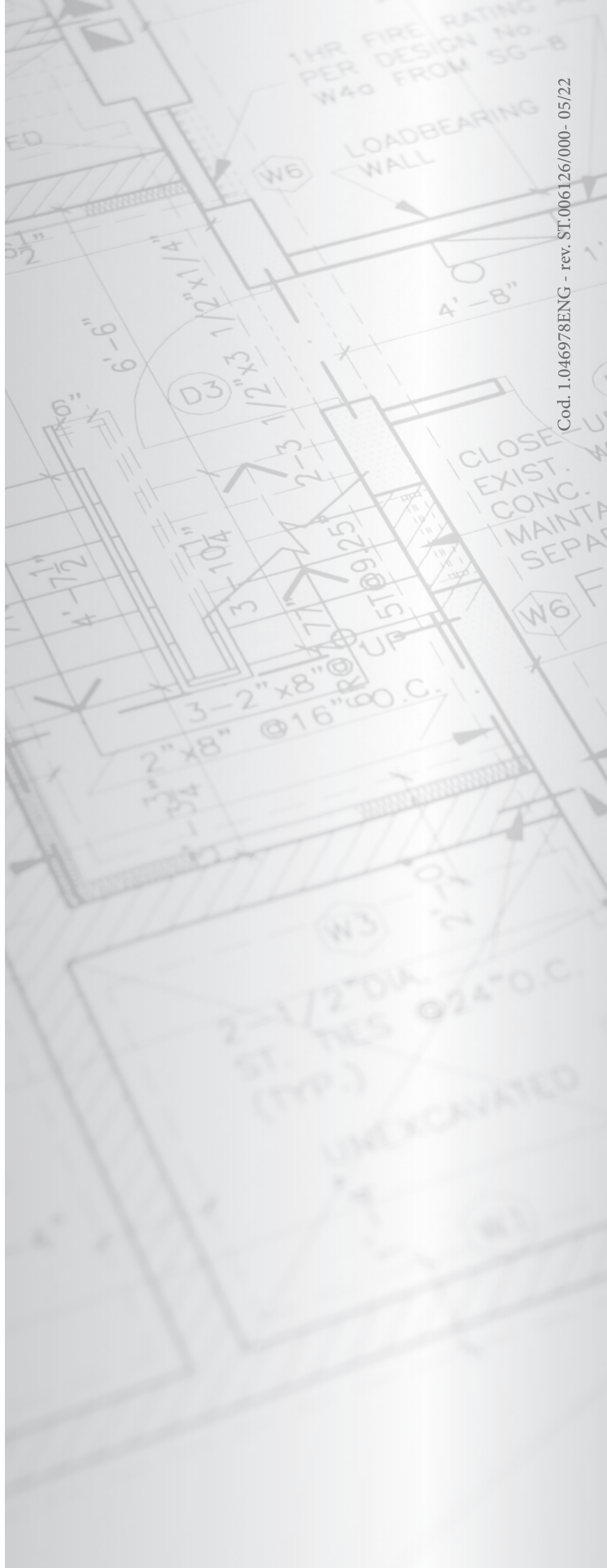

Cod. 1.046978ENG - rev. ST.006126/000-05/22



[immergas.com](http://immergas.com)

Immergas S.p.A.  
42041 Brescello (RE) - Italy  
Tel. 0522.689011  
Fax 0522.680617